

DRAWING NO.
172.2M.52.005/F

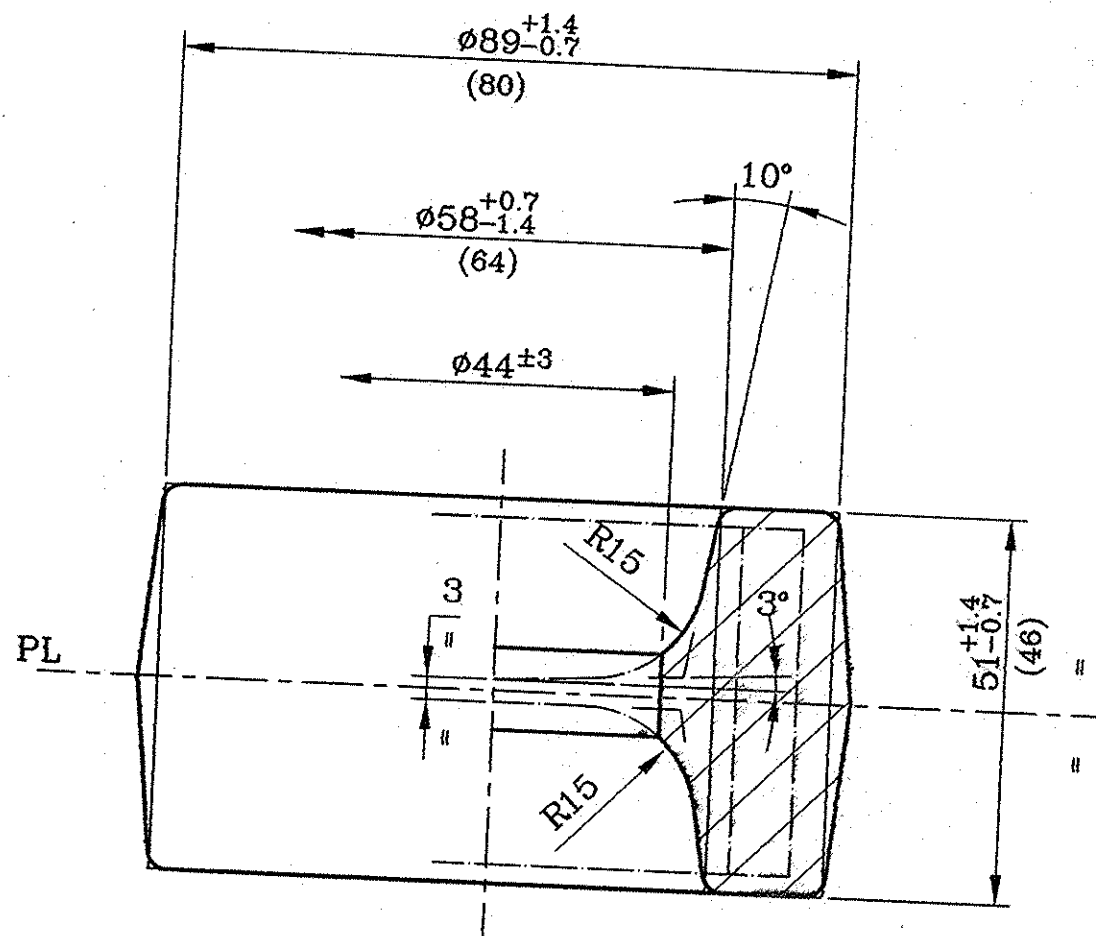

MODIFICATIONS & ADDITIONS		
ISSUE	MODIFICATIONS & 'N' OF 'A'	SIGN.
A	REDRAWN	<i>[Signature]</i> 9/14

TECHNICAL REQUIREMENTS.

- | | |
|--|--|
| <p>01. HEAT TREAT. NORMALISE & TEMPER
DIA.OF IND. 3.7 - 4.2 MM(269-207 BHN.)</p> <p>02. DE-SCALE</p> <p>03. DEPTH OF SURFACE DEFECTS AND SCALE
PITS UPTO 0.5 OF ACTUAL MACHINING
ALLOWANCE ARE ALLOWED.</p> <p>04. MISMATCH SHOULD NOT EXCEED 0.6 MM.</p> <p>05. RESIDUAL FIN ALONG THE PARTING LINE
SHOULD NOT EXCEED 0.8 MM.</p> <p>06. FOLDING OF FIN IN PIERCED HOLE IS
ALLOWED.</p> | <p>07. MARK PART NO. & STEEL GRADE INDEX "2C"</p> <p>08. UNSPECIFIED DRAFT = 7°</p> <p>09. UNSPECIFIED RADII = R 2.5 MM.</p> <p>10. MACHINING DIMENSIONS ARE SHOWN IN BRACKETS.</p> <p>11. UNTOLERANCED DIMENSIONS ARE FOR CONSTRUCTION.</p> <p>12. ECCENTRICITY OF PIERCED HOLE SHOULD NOT EXCEED
2.0 MM.</p> <p>13. PAINT RED OXIDE.</p> |
|--|--|

T-72

MATERIAL		FORGING WT.		
20X2H4A GOST 4543-71		1.94 KGS		
ALT. MATERIAL		HAMMER		SCALE
				1:1
DRAWN	CHECKED	APPROVED	AUTHD.	
<i>[Signature]</i> 9/14/10	<i>[Signature]</i> 9/14/10	<i>[Signature]</i> 9/14/10	<i>[Signature]</i> 10/14/2010	
DRAWING NO. 172.2M.52.005/F				
NOMENCLATURE: BUSHING, OUTER				
HEAVY VEHICLES FACTORY AVADI, CHENNAI				