

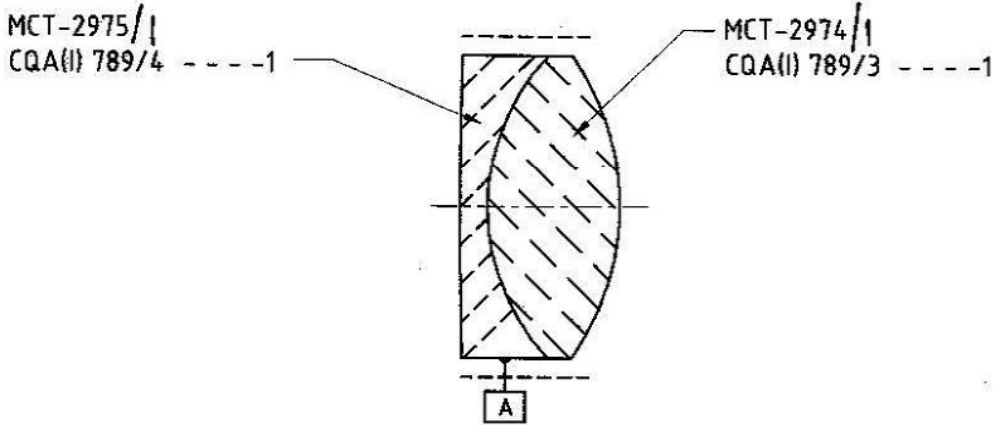

BINOCULAR 8x30 R LENS OPTICAL INSTRUMENT

DRG. NO.
CQA(I) 789/SA-2



----- BLACK LAQUERED

<p>R 414.336 (</p> <p>FREE ϕ16.3</p> <p>COATING: MCS001-1</p> <p>CHAMFER 0.1...0.3</p> <p>MCT-2975/1 CQA(I) 789/4</p>	<p>-0.04</p> <p>ϕ22 -0.07</p> <p>Md 11.55 \pm0.1</p> <p>4/0 .05</p> <p>OPTICAL CEMENT</p> <p>----- BLACK LAQUERED</p>	<p>R 19.247)</p> <p>FREE ϕ21</p> <p>COATING: MCS001-1</p> <p>CHAMFER 0.1...0.3</p> <p>MCT-2974/1 CQA(I) 789/3</p>
--	---	---

	DR. - P.C.SINGH	DT. 31-10-11	SCALE - 2:1
	TR. -	MATL. AS ABOVE	TREAT. AS ABOVE
	CH.	SHEETS-1	SHTNO.-1
DA-01/15 dt -02/01/15 AMENDMENTS.	APPROVED:	DRAWING NO - MCT-2973/1	
OFD/DO/002	 		

ORDNANCE FACTORY, DEHRADUN.

BINOCULAR 8x30 R LENS OPTICAL INSTRUMENT

DRG. NO.
CQA(I) 789/3

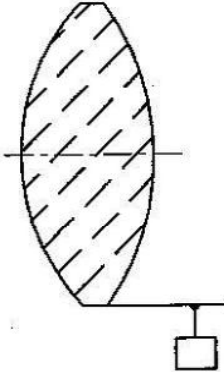

ORDNANCE FACTORY, DEHRADUN.

LEFT SURFACE	MATERIAL	RIGHT SURFACE
R 16.045 (GLASS TYPE HOYA T ₆ C 6	R 19.247)
FREE ϕ 19	-0.04	FREE ϕ 21
3/5 (1) (CENTERING ACCURACY)	ϕ 22 -0.07	3/5 (1)
5/1 x 0.1 (SURFACE ACCURACY)	Md 9.55 \pm 0.1	5/1 x 0.1
CEMENTING FACE	1/3 x 0.063	COATING: MCS001-1
CHAMFER 0.1 ... 0.3	2/0	CHAMFER 0.1 ... 0.3
	4/0.05	
	6/10	

	DR.- P.C.SINGH	DT. 31-10-11	SCALE- 2:1
	TR.-	MATL.	TREAT.
	CH.	AS ABOVE	AS ABOVE
		SHEETS-2	SHTNO.-1
DA. No. 01/15 Dt. 02/01/2015	APPROVED:	<u>DRAWING No.-</u> <u>MCT-2974/1</u>	
AMENDMENTS.			
OFD/DO/002	JWM/DO.		

BINOCULAR 8x30 R

LENS OPTICAL INSTRUMENT

DRG. NO.
CQA(I) 789/3

ORDNANCE FACTORY, DEHRADUN.

STEINER OPTIK GERMANY	Thin Film Technology Antireflexion Coating (AR)	Data sheet for MCS001-1
<p>Description:</p> <p>Standard - AR coating with MgF2 evaporated on heated substrate.</p> <p>The reflected colour of the surface should be like magenta blue.</p>		
<p>Description of tolerance:</p> <p>Peak at $\lambda = 530 \text{ nm} \pm 5\%$</p> <p>Order of tests:</p> <ol style="list-style-type: none"> 1. Surface has to be cleaned with acetone. 2. The adhesive tape has to be fixed lightly and yanked off jerkily. 3. An eraser has to be moved to and fro ten times. 		

	DR. - P.C.SINGH	DT. 31-10-11	SCALE-
	TR.-	MATH.	TREAT.
	CH.	AS ABOVE	AS ABOVE
		SHEETS-2	SHTNo.-2
DA-01/15, dt 02/01/15 AMENDMENTS. OFD/DO/002	APPROVED JWN/DO	DRAWING No.- MCT-2974/1	

BINOCULAR 8x30 R

LENS OPTICAL INSTRUMENT

DRG. NO.
CQA(I) 789/4

ORDNANCE FACTORY, DEHRADUN.

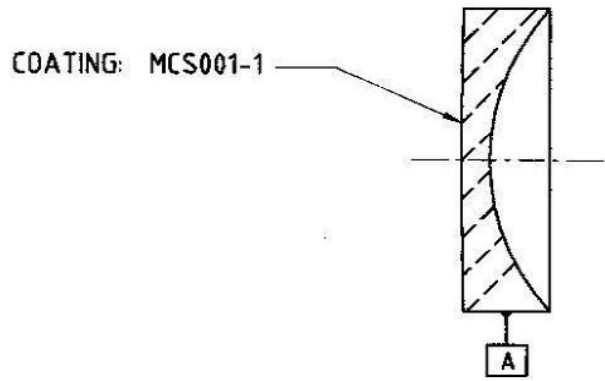

LEFT SURFACE	MATERIAL	RIGHT SURFACE
R 414.336 (GLASS TYPE SCHOTT SF 11	R16.046 (
FREE ϕ 16.3	GLASS TYPE HOYA FD 110	FREE ϕ 19
3/5 (1) (CENTERING ACCURACY)	-0.04	3/5 (1)
5/1 x 0.1 (SURFACE ACCURACY)	ϕ 22.0 -0.07	5/1 x 0.1
COATING: MCS001-1	Md 2.0 \pm 0.1	CEMENTING FACE
	1/3 x 0.063	
	2/0	
	4/0.05	
CHAMFER 0.1...0.3	6/10	CHAMFER 0.1...0.3

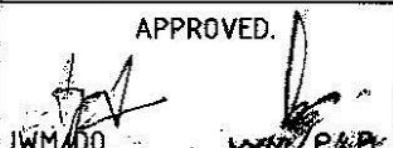
		DT. 31-10-11	SCALE- 2:1
		MATL.	TREAT.
		AS ABOVE	AS ABOVE
		DR. - P.C.SINGH	
		TR. -	
		CH.	
		SHEETS-2	SHTNO.-1
DA-01/15 dt 02/01/15		APPROVED.  JWMDO. P&P.	
AMENDMENTS.			
OFD/DO/002			
		DRAWING No. -	
		MCT-2975/1	

BINOCULAR 8x30 R

LENS OPTICAL INSTRUMENT

DRG. NO.
CQA(I) 789/4

STEINER OPTIK GERMANY	Thin Film Technology Antireflexion Coating (AR)	Data sheet for MCS001-1
--------------------------	--	----------------------------

Description:

Standard - AR coating with MgF2 evaporated on heated substrate.
The reflected colour of the surface should be like magenta blue.

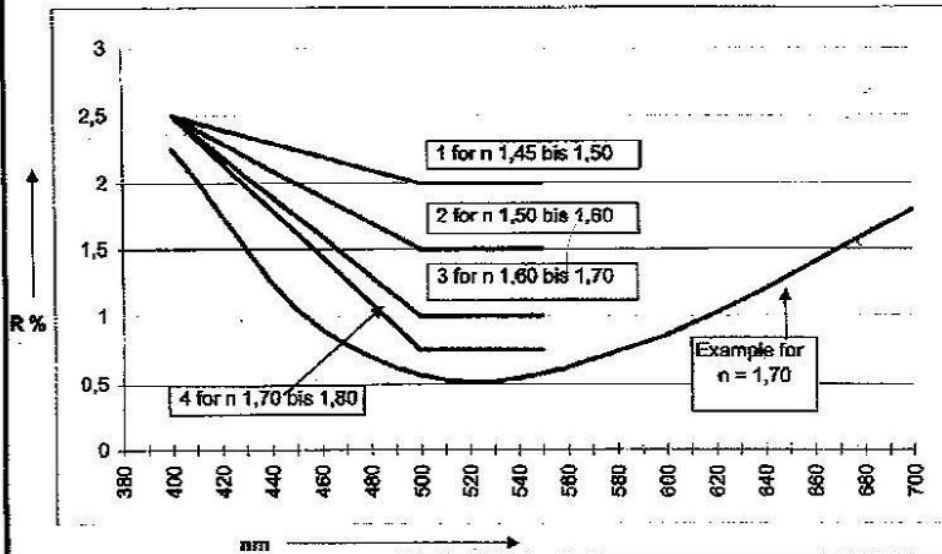

Description of tolerance:

Peak at $\lambda = 530 \text{ nm} \pm 5\%$

Order of tests:

1. Surface has to be cleaned with acetone.
2. The adhesive tape has to be fixed tightly and yanked off jerkily.
3. An eraser has to be moved to and fro ten times.

		DT. 31-10-11	SCALE - 2:1
		DR. - P.C.SINGH	MTRL.
		TR. -	AS ABOVE
		CH.	SHTNO. - 2
DA-01/15 dt - 02/01/15		APPROVED.	
AMENDMENTS.			
OFD/DO/002		DRAWING No. -	
		MCT-2975/1	

BINOCULAR 8x30 R

LENS OPTICAL INSTRUMENT

DRG. NO
COA/II 789/27

FIRST ANGLE PROJECTION

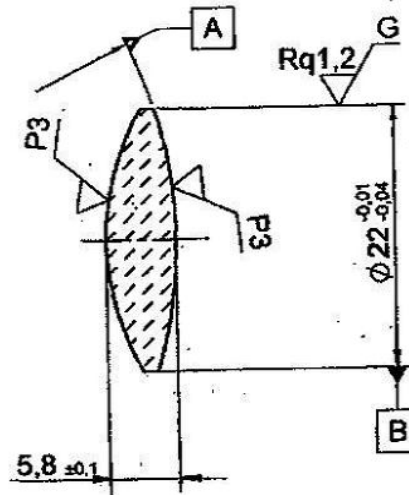

LEFT SURFACE	MATERIAL	RIGHT SURFACE
R 21.830 CX	HOYA B&CD 5	R 36.750 CX
phi 21		phi 21
CHAMFER 0.2-0.3	n _e 1.59142 +/- 0.001	CHAMFER 0.2-0.3
COATING: MCO01-1	v _e 61.01 +/- 0.8%	COATING: MCO01-1
3/5 (1)		3/5 (1)
CENTERING ACCURACY		
4/4 SURFACE ACCURACY	0/10	4/-
5/1 x 0.1	1/3 x 0.063	5/1 x 0.1
	2/2; 2	

DT. - 18-06-2010 SCALE - NTS

MADE BY: P.C.SINGH	MATL.	TREAT.
TR-	AS ABOVE	AS ABOVE
CH-	SHEETS. 2	SHT. NO. 1

~~DA-01/15 dt-02/01/15~~
AMENDMENTS
OFD/DO/002

APPROVED

JWM/D.O. WM/PLP

DRAWING NO.
MCT-2980/1

ORDNANCE FACTORY, DEHRADUN

ORDNANCE FACTORY, DEHRADUN.

BINOCULAR 8x30 R LENS OPTICAL INSTRUMENT

DRG. NO.
CQA(I) 789/27

STEINER OPTIK GERMANY	Thin Film Technology Antireflexion Coating (AR)	Data sheet for MC001-1
--------------------------	--	---------------------------

Description:

Standard two layer AR-coating evaporated on heated substrate.

The reflecting colour of the surface should be like magenta blue.

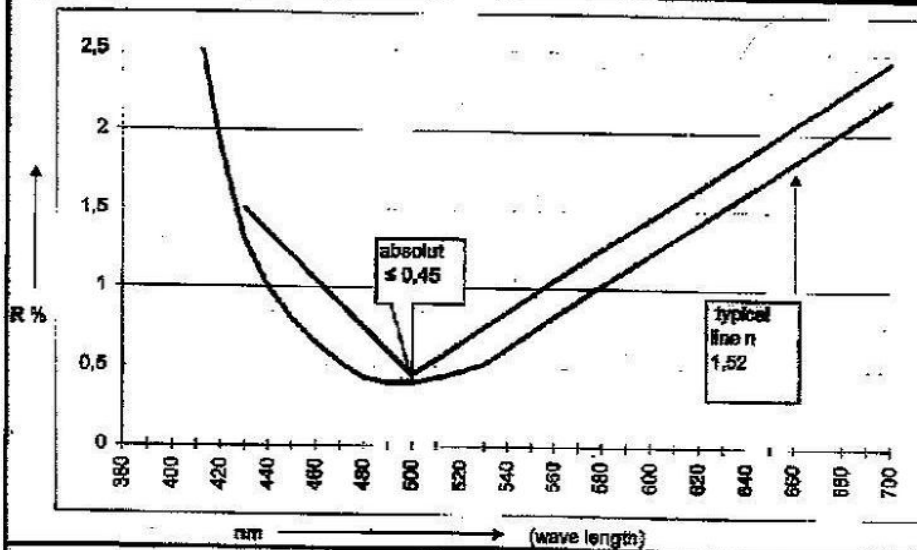

Description of tolerance:

Peak at Lambda = 500 +/- 5%

Order of tests:

1. Surface has to be cleaned with acetone.
2. The adhesive tape has to be fixed tightly and yanked off jerkily.
3. An eraser has to be moved to and fro ten times.

		DT. 31-10-11	SCALE-
	DR. - P.C.SINGH	MATERIAL	TREAT.
	TR. -	AS ABOVE	AS ABOVE
	CH.	SHEETS-2	SHTNo.-2
DA-01/15 dt-02/01/15	APPROVED.	DRAWING NO-	
AMENDMENTS.		MCT-2980/1	
OFD/DO/002	JWM/DO.		
		WM/P&P.	

BINOCULAR 8x30 R LENS OPTICAL INSTRUMENT

DRG. NO
COA(I) 789/31

FIRST ANGLE PROJECTION

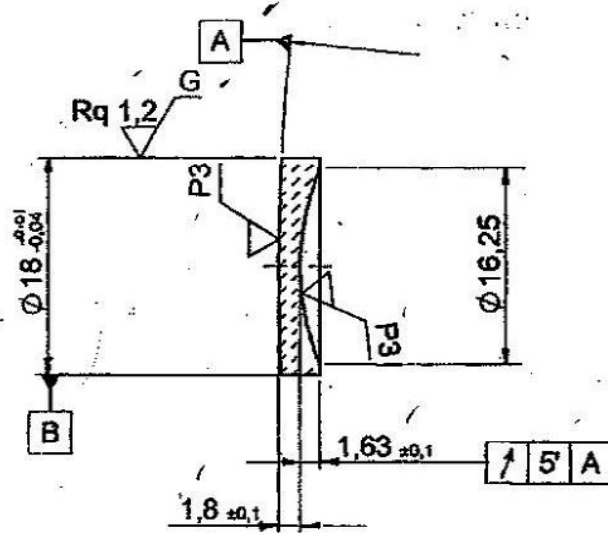
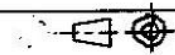

LEFT SURFACE	MATERIAL	RIGHT SURFACE
R 178.685 CX ϕ_e 17 CHAMFER 0.3 ± 0.05 COATING: MCS001-1 3/4 (1) (CENTERING ACCURACY) 4/- (SURFACE ACCURACY) 5/3 x 0.063	SCHOTT SF 11/785258 n_e 1.79190 ± 0.001 n_o 25.55 ± 0.8% 0/10 1/3 x 0.025 2/2; 2	R 21.071 CC ϕ_e 16 CHAMFER 0.3 ± 0.05 COATING: MCS001-1 3/4 (1) 4/5' 5/3 x 0.063
		DT. - 18-06-2010
	MADE BY: P.C.SINGH	SCALE - NTS
	TR-	MATL. AS ABOVE
	CH-	TREAT. AS ABOVE
		SHEETS. 2
		SHT. NO. 1
DA-01/15 dt. 02/01/15	APPROVED	DRAWING NO.
AMENDMENTS		MCT-2981/1
OFD/DO/002	JWM/D.O.	WM/PrP

ORDNANCE-FACTORY, DEHRADUN

BINOCULAR 8x30 R

LENS OPTICAL INSTRUMENT

DRG. NO.
CQA(I) 789/31

ORDNANCE FACTORY, DEHRADUN.

STEINER OPTIK GERMANY	Thin Film Technology Antireflexion Coating (AR)	Data sheet for MCS001-1
--------------------------	--	----------------------------

Description:

Standard - AR coating with MgF2 evaporated on heated substrate.
The reflected colour of the surface should be like magenta blue.

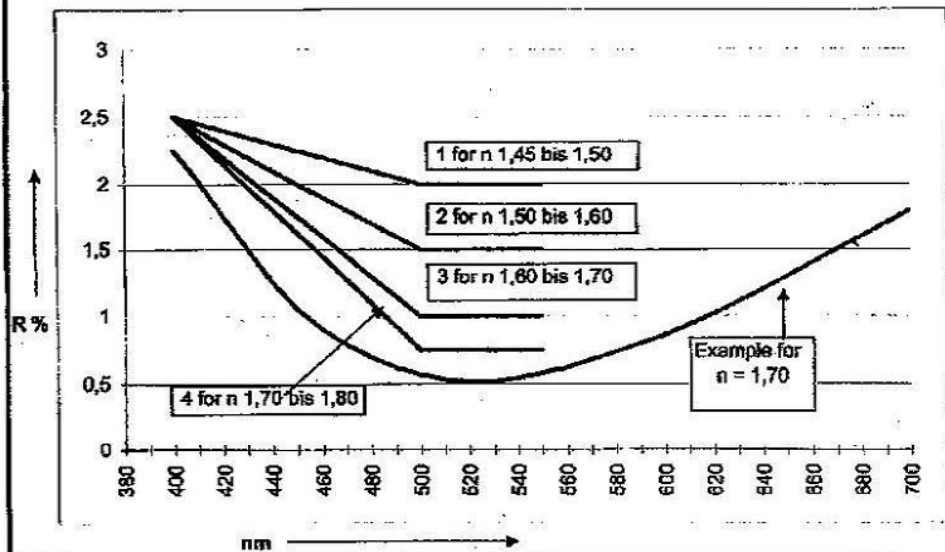

Description of tolerance:

Peak at $\lambda = 530 \text{ nm} \pm 5\%$

Order of tests:

1. Surface has to be cleaned with acetone.
2. The adhesive tape has to be fixed tightly and yanked off jerkily.
3. An eraser has to be moved to and fro ten times.

		DT. 31-10-11	SCALE-
		DR. - P.C.SINGH	MATERIAL TREATMENT
		TR. -	AS ABOVE AS ABOVE
		CH.	SHEETS-2 SHTNo.-2
DA-01/15 dt 02/01/15		APPROVED.	
AMENDMENTS.		DRAWING NO-	
OFD/DO/002		MCT-2981/1	
JWM/DO.		WMIP&P	