

- ⑩ 1 IT IS ALLOWED TO MANUFACTURED FROM STEEL GRADE 15A1, 20A1, 30A1 AND 35A1 - I GOST 977-6575
2. REQUIREMENTS FOR CASTING SHOULD BE AS PER 172 TY-10, ON ACCEPTANCE OF COMPONENTS MADE BY INVESTMENT CASTINGS.
- 3 PERMISSIBLE-DEVIATIONS ON ROUGH DIMENSIONS SHOULD BE AS PER ACCURACY CLASS 2. OF GOST 2009-55.
- 4 UNSPECIFIED RADII SHOULD NOT EXCEED 3 mm
- 5 IT IS ALLOWED TO MANUFACTURE AS PER THE DOTTED LINE.

EXPLANATORY NOTE :-

6. REFERENCE MATERIAL QUOTED -- STEEL 25A - I GOST 977-75. ALLOYED AND UNALLOYED STRUCTURAL STEEL CASTING GRADE 25A GROUP I FOR GENERAL PURPOSE AND MANUFACTURED IN ACCORDANCE WITH GOST 977-75.
- REFERENCE NOTE 1. ON ALTERNATIVE MATERIAL STEEL GRADES 15A1, 20A1, 30A1, AND 35A1 GOST 977-75.
- ALLOYED AND UNALLOYED STRUCTURAL STEEL CASTING GRADE 30A GROUP I FOR GENERAL PURPOSE AND MANUFACTURED IN ACCORDANCE WITH GOST 977-75
- CHEMICAL COMPOSITION AS PER STEEL GRADES 25A & 30A TO GOST 977-75.

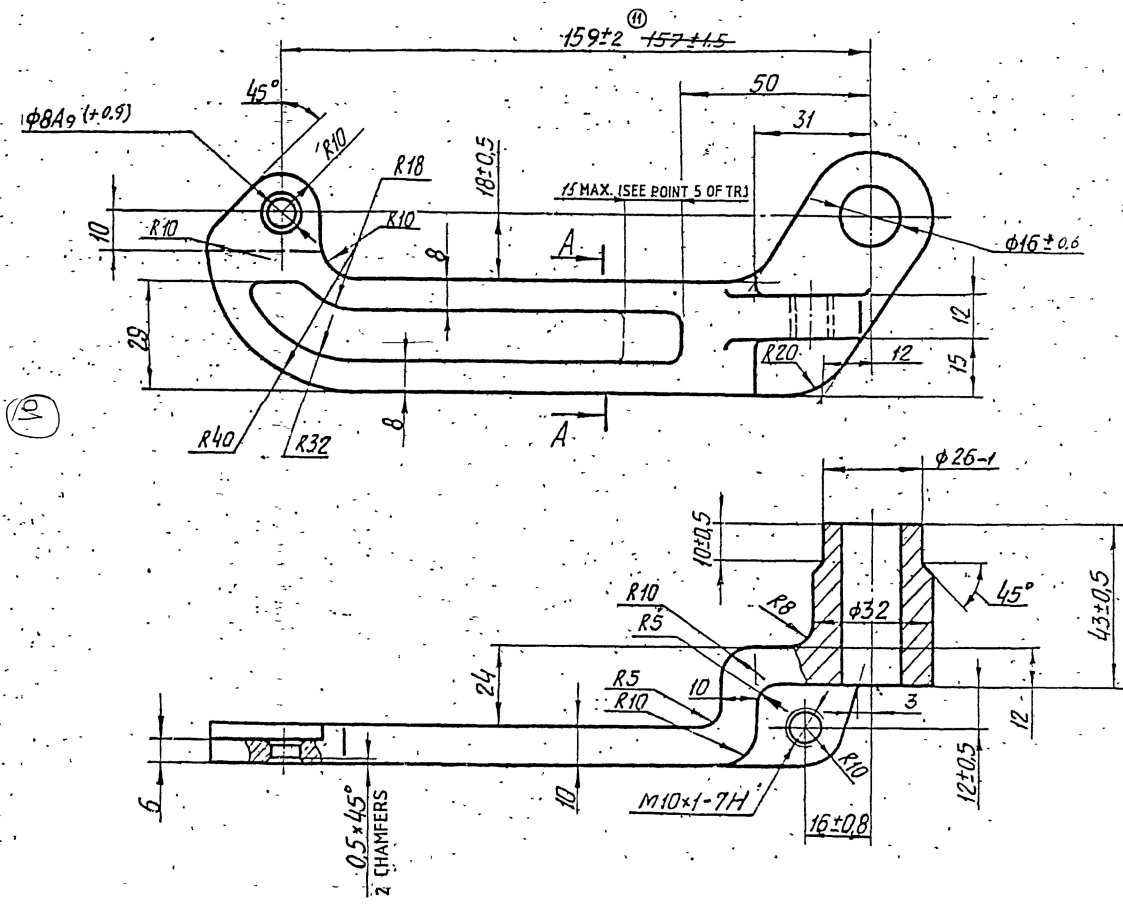
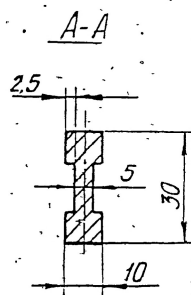

GRADE OF STEEL	CONTENT OF ELEMENTS %							ADMIXTURES MAX %	
	C	Mn	Si	Cr	Ni	Cu	S	P	
25A	0.22 -0.30	0.35 0.90	0.20 0.52	0.30 MAX	0.30 MAX	0.30 MAX	0.05	0.05	
30A	0.27 -0.35	0.40 0.90	0.20 0.52	0.30 MAX	0.30 MAX	0.30 MAX	0.05	0.05	

DRAWING REDRAWN BASED ON INDIANISED DRG. ISSUE - 11 COMMON TO BLT

PILOT SAMPLE SHOULD BE APPROVED BY A H S P BEFORE BULK PRODUCTION.

EST. WT.	TO BE STAMPED OR MARKED WHERE INDICATED THUS (LETTERS)
0.56	

ALL SHARP EDGES AND CORNERS TO BE REMOVED. UNLESS OTHERWISE STATED MACHINED CORNERS TO HAVE R OUT - CHAMFERED TO HAVE R OUT. CHAMFERS ARE PERMISSIBLE

DRN		MATERIAL	⑩ STEEL 25A, GOST 977-75	USED ON	175 63 029 (6-1)
CHD		CONTROLLERATE OF QUALITY ASSURANCE (HEAVY VEHICLES)			
TCD		A V A D I			
APPD		TITLE	BRACKET		
DATE	15-12-93	TOLERANCE ON DIMS UNLESS OTHERWISE STATED IS 2102-63			
SCALE	1:1	ALL THREADS TO CONFORM TO	D S CAT NUMBER		
DIMENSIONS IN	mm		DRAWING NUMBER		

11	16-1-93	NOTN No 172M 512A - 89 AL No 13/2			
10	16-1-89	AHDT. LIST No 6, PART II, BOOK - 9			

F=102
SIZE A2