

DIMENSIONS ARE IN mm.

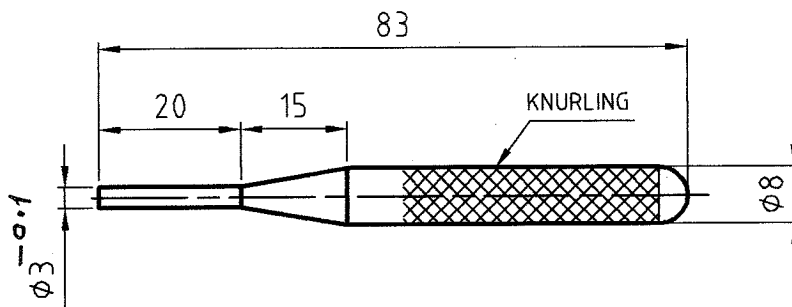

MARKING (SUITABLY) ON SAMPLE/ TAG
 YR.OF Mfg.
 MANUFACTURER'S CODE
 DRG.NO

FINISH:--
 PHOSPHATE TO SPECIFICATION JSS 0465-01:1988
 CLASS II(ACCELERATED)OIL FINISH

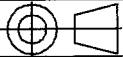

MATERIAL :- STEEL BS.970 PT.1:1983 Gd.070 M55

HARDNESS:-425-475 HV

PART NO.	DESCRIPTIONS	NO OFF	MATERIAL	TREATMENT	REMARKS
 TRACED DRAWN <i>B. S. ...</i> CHECKED <i>J. ...</i> OIC/D&DO <i>Jand...</i> OFFICER/PRODN. OFFICER/D&DO	SIGNATURE & DATE.	SUB: PIN PUNCH 3mm			SCALE 1:1
		FOR: TOOLS & ACCESSORIES			STORE DRG.NO.
		OF: 40mm MGL			-
		DES.REF.NO.			OPERATION NO.
		DRG. No.: 30T 1700 012 A4			-
		 ORDNANCE FACTORY TIRUCHIRAPPALLI-16.			SHEETS: 1
AMENDMENTS	SIG. & DATE	APPROVED ON. 20/12/2007	SHEET No.: 1		