

DRG. NO X 1915215

The copyright of this drawing and all attachment there of belongs to the Indian Ordnance Factories, Ministry of Defence, Govt. of India. This should not be copied, reproduced in any way or the information contained therein made available to unauthorised persons without the written permission of the Director General of Ordnance Factories.

**SEALED
CERTIFIED CORRECT**

COPY DATE
SIGNATURE

ALL DIMENSIONS ARE IN m.m.

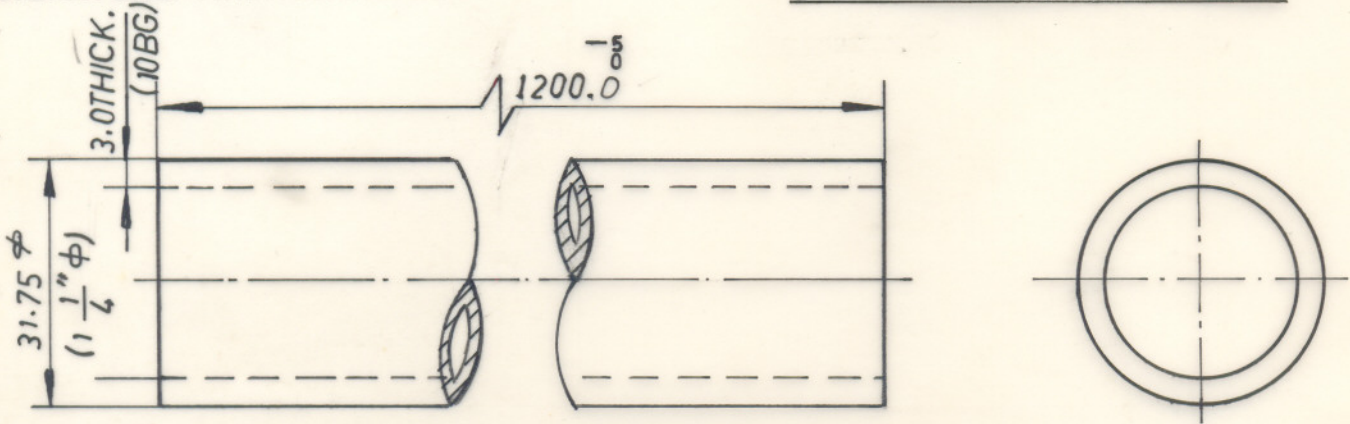

MATERIAL — STEEL TUBE TO IS 3074 ERW-1

REMARKS — F23 - 6 x 6 FCT WHEEL NUT SPANNER.

FOR HOSUR UNIT

(SURFACE TREATMENT CODE NO. - 01)

TO BE PHOSPHATED TO CLASS 'C' ASPER IS: 3618 - 1996.

TO BE COATED WITH ZINC PHOSPHATE GREY PRIMER TO ALPS 04.

MINIMUM THICKNESS — 25 MICRONS.

TO BE PAINTED WITH BLACK STOVING ENAMEL TO AL PS - 06 .

MINIMUM THICKNESS — 25 MICRONS.

TOTAL THICKNESS OF COATING — 55 MICRONS MINIMUM .

Gen Tol/Not Specified										Date		Name		Approved	
Linear Dimension										Drawn					
0-6	±0.1									Traced		26.8.02		Rai	
6-30	±0.2									Checked		26.8.02		TH D.SAR	
30-120	±0.3									JWM/SFD		27.8.02		Raj	
120-315	±0.5														
315-1000	±0.8														
1000-2000	±1.2			DRAWING RETRACED		26.8.02		JYM						JGM/TS	
Angular Dim.		Index		ALTERATION		Date		D. O.							
0-10	±1°														
10-50	±30'														
50-100	±20'														
> 100	±10'														

- ~ Unmachined
- ▽ Rough
- ▽▽ Smooth
- ▽▽▽ Finish
- Ⓣ C.Hard
- ⓉⓉ Hardened
- ⓉⓉⓉ Gr. after Hard.

Description **TUBE EXTENSION**
TOOLS AND SPARES
 For
STALLION MARK - III
 Group

Scale **1:1**
 Ref. Drg.
 Replaced by
 Replacement for



**VEHICLE FACTORY
JABALPUR**

X 1915215

A