

NOTES:

- 1. ASME Y14.5M-1994 APPLIES.
- 2. FINISH  $\sqrt{3.2}$  EXCEPT AS NOTED.
- 3. BREAK EDGES  $0.076 + 0.305$  UNLESS OTHERWISE SPECIFIED.
- 4. HEAT TREATMENT: A) FOR MATERIAL; 4147, 4150: HEAT AT  $816^\circ - 843^\circ \text{ C}$ . IN A PROTECTIVE ATMOSPHERE. OIL QUENCH. TEMPER FOR 1 HOUR MIN TO RH C50-57.
- 5. FINAL PROTECTIVE FINISH: FINISH 5.3.1.2 OR 5.3.2.2 OF MIL-STD-171.
- 6. MATERIAL: STEEL, ASTM A322 OR A331: 4147, 4150, 6150, 41L50.

REVISIONS				
ZONE	REV.	DESCRIPTION	DATE	APPROVED
	A	CREATE DRAWING	08/07/14	J. HERSHBERGER
C7	B	ADDED HARDNESS SPECIFICATION.	6/21/2017	BAS
	C	UPDATED TO DDW CAGE CODE	3/29/2018	G. HERSHBERGER
	D	UPDATED DRAWING NOTES	6/6/2018	T. HARDMAN

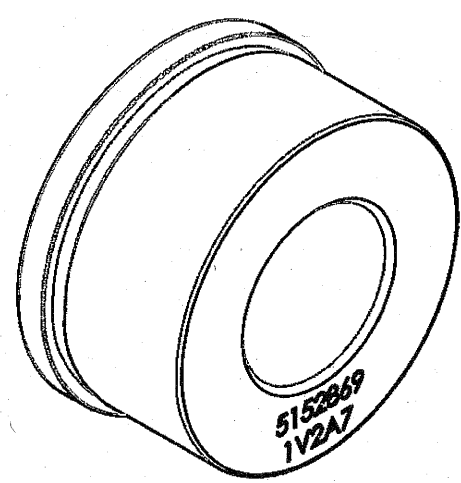
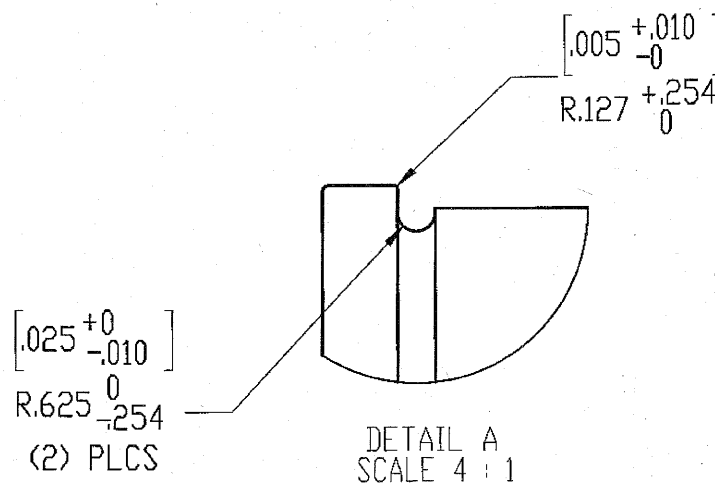
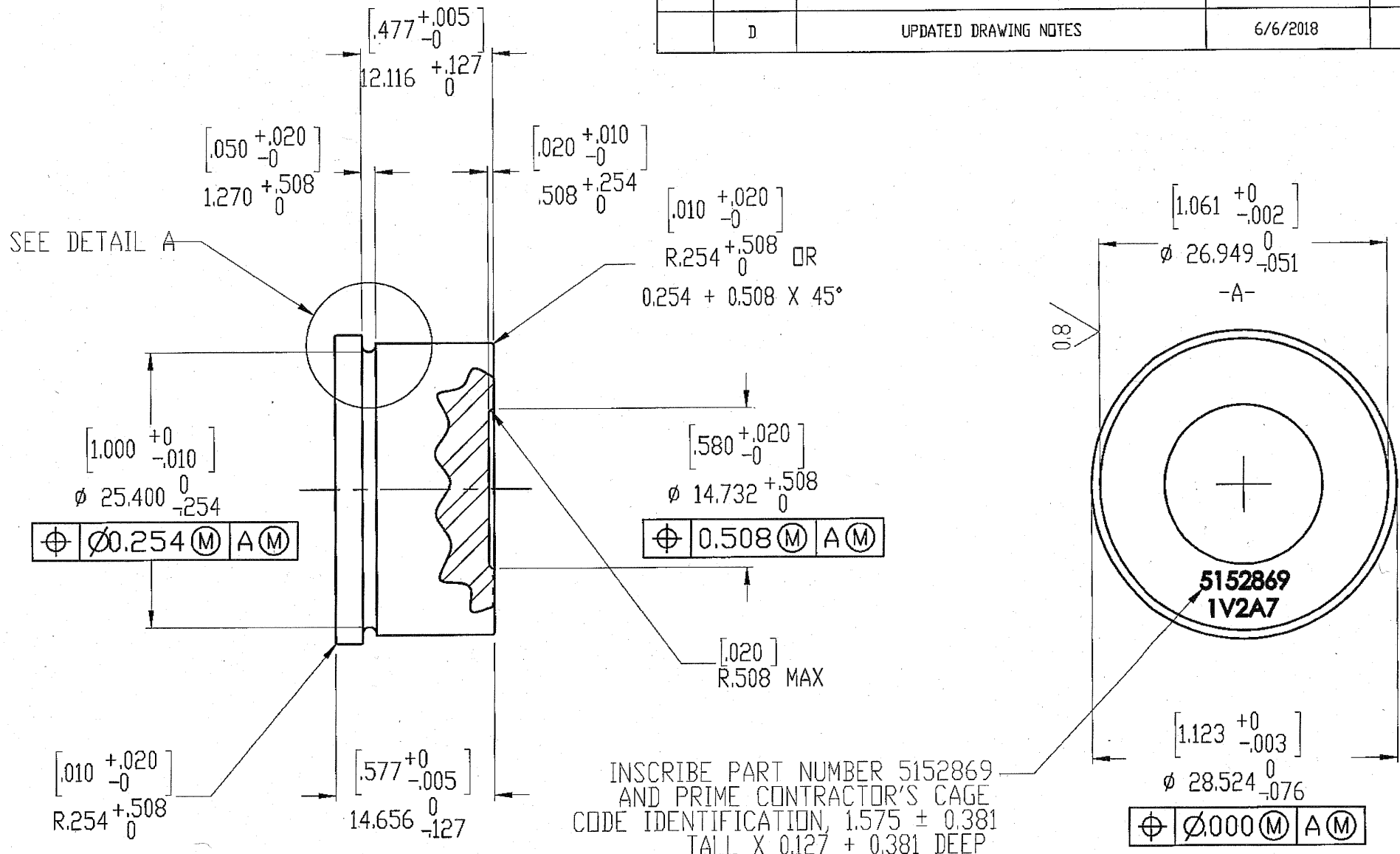

UN CONTROLLED COPY  
CERTIFIED CORRECT COPY OF APPROVED DRAWINGS AT THIS DATE: 29.09.2021  
DESIGN & DRAWING OFFICE: ORDNANCE FACTORY, TIRUCHIRAPPALLI-620 015  
24 AUG 2021  
Handwritten signature and date.

ITAR CONTROLLED  
THIS DOCUMENT IS CONTROLLED UNDER THE ITAR. IT MAY NOT BE PROVIDED TO A NON-U.S. RESIDENT WITHOUT THE WRITTEN APPROVAL OF THE U.S. GOV'T. VIOLATIONS WILL RESULT IN CIVIL OR CRIMINAL PENALTIES.  
PROPRIETARY AND CONFIDENTIAL.  
THE INFORMATION CONTAINED IN THIS DRAWING IS THE SOLE PROPERTY OF DDIO ORDNANCE WORKS, INC. ANY REPRODUCTION IN PART OR AS A WHOLE WITHOUT THE WRITTEN PERMISSION OF DDIO ORDNANCE WORKS, INC. IS PROHIBITED.

NAME	DATE
DRAWN: PMD	08/07/14
CHECKED:	
ENG APPR.:	
MFG APPR.:	
QA:	
COMMENTS:	

DDIO ORDNANCE WORKS, INC.  
PLATE, BUFFER, DDW50BMG  
SIZE B 5152869 REV D  
SCALE: 2:1 WEIGHT: SHEET 1 OF 1