

NOTES:

1. FINISH $\sqrt{3.2}$
2. BREAK EDGES 0.076 + 0.305 UNLESS OTHERWISE SPECIFIED.
3. MATERIAL: STEEL, ASTM A108, 1045, 1040, 1050 OR ASTM A331 OR A322, 4140, 4340.
4. HEAT TREATMENT: HEAT AT 838 TO 860 °C. OIL QUENCH. TEMPER 1 HOUR MIN. TO HARDNESS SPECIFIED (RH C26-32).
5. FINAL PROTECTIVE FINISH: FINISH 5.3.1.2 OR 5.3.2.2 OF MIL-STD-171.
6. ASME Y14.5M-1994 APPLIES.

REVISIONS				
ZONE	REV.	DESCRIPTION	DATE	APPROVED
	B	ADDED MAJOR DIAMETER TOLERANCE TO .25-28 THREAD	1/15/2019	G. HERSHBERGER

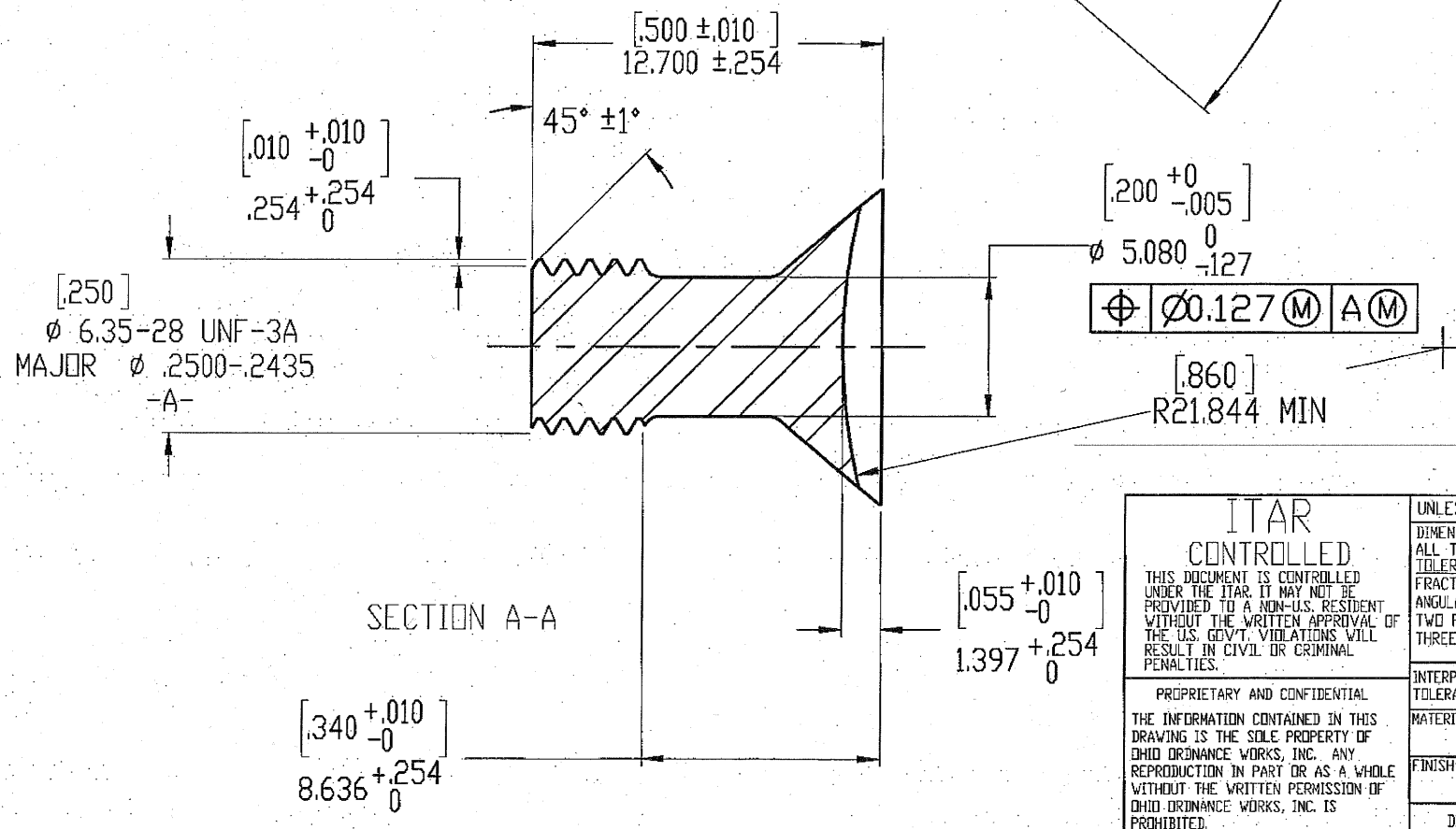
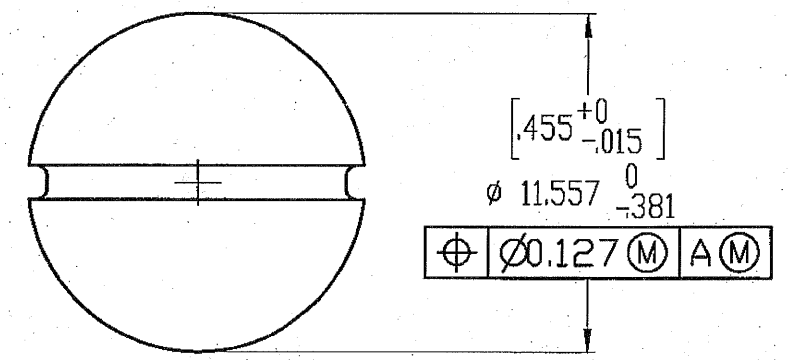
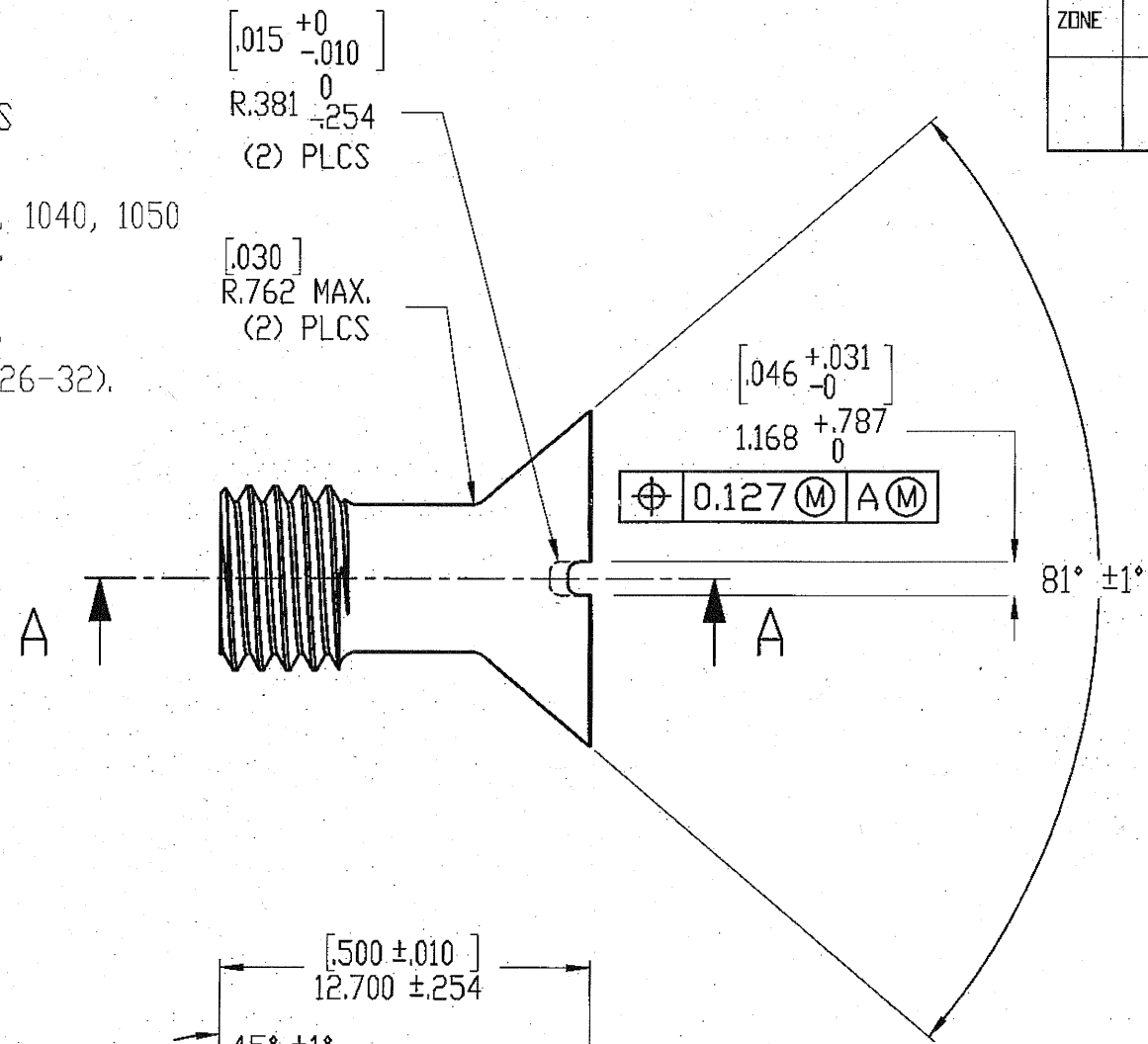

UN CONTROLLED COPY
 CERTIFIED CORRECT COPY OF APPROVED
 DRAWINGS AT THIS DATE 29.09.21

DESIGN & DRAWING OFFICE,
 ORDNANCE FACTORY, TIRUCHIRAPPALI - 620 016.

अनुमोदित रूप से प्रमाणित
 Provisionally Approved

24 AUG 2021
 दिनांक

हस्ताक्षर / Sig
 For Control (At)

ITAR CONTROLLED THIS DOCUMENT IS CONTROLLED UNDER THE ITAR. IT MAY NOT BE PROVIDED TO A NON-U.S. RESIDENT WITHOUT THE WRITTEN APPROVAL OF THE U.S. GOV'T. VIOLATIONS WILL RESULT IN CIVIL OR CRIMINAL PENALTIES. PROPRIETARY AND CONFIDENTIAL THE INFORMATION CONTAINED IN THIS DRAWING IS THE SOLE PROPERTY OF OHIO ORDNANCE WORKS, INC. ANY REPRODUCTION IN PART OR AS A WHOLE WITHOUT THE WRITTEN PERMISSION OF OHIO ORDNANCE WORKS, INC. IS PROHIBITED.	UNLESS OTHERWISE SPECIFIED DIMENSIONS ARE IN MM/(INCHES) ALL THREAD DIM. ARE IN INCHES TOLERANCES: FRACTIONAL ANGULAR: MACH ± BEND TWO PLACE DECIMAL ±0.25 THREE PLACE DECIMAL ±0.127	NAME PMD	DATE 04/08/15	OHIO ORDNANCE WORKS, INC. SCREW, EXTERNALLY RELIEVED BODY, DDW50BMG		
	INTERPRET GEOMETRIC TOLERANCING PER: MATERIAL FINISH	DRAWN CHECKED ENG APPR. MFG APPR.	COMMENTS:		SIZE B	REV B
	DO NOT SCALE DRAWING	SCALE: 4:1	WEIGHT:		SHEET 1 OF 1	
	SIZE B	PART NO. 7312028	REV B			