

DRAWING NUMBER  
219.35cb-167Cb

SHEET No. 1 OF 1

These drawings are only for reference.  
Actual drawings may be different and  
shall be issued at the time for  
procurement.

No part of these drawings may  
be reproduced in any form  
without prior permission in  
writing of OFM.

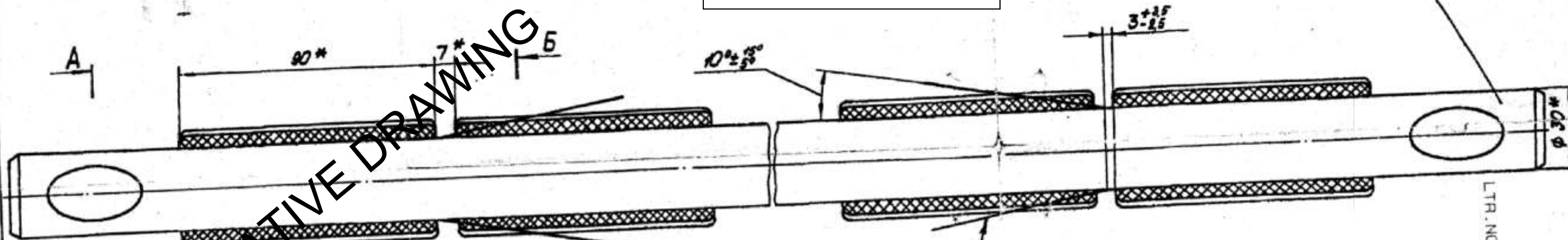

INDICATIVE DRAWING

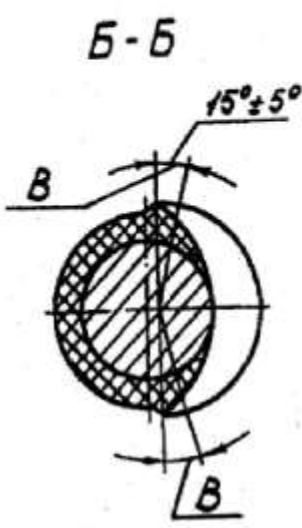
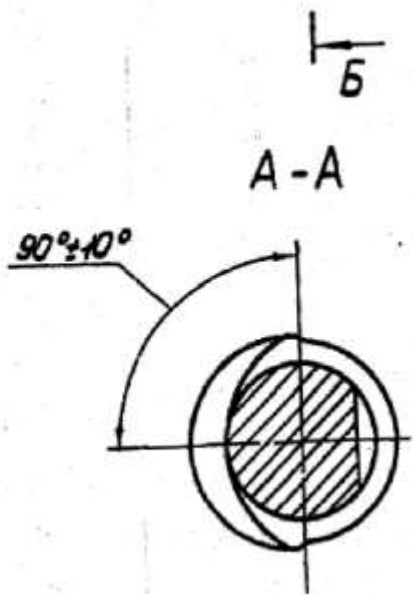

1. В точке соприкосновения иглы и пальца должен быть электрический контакт.  
 2. Прямолинейность игл после запрессовки не контролировать.  
 3.\* Размеры для справок.  
 4. Допускается запрессовка игл поз. 3 на участках B.  
 5. Остальные требования по 520.TY1.
1. Electrical contacts should be available in mating point of needle and pin.  
 2. After assembly, recti-linearity of needles need not be checked.  
 3. \*Dimensions for reference.  
 4. Press-fitting of needle Item 3 on sections B is permitted.  
 5. Other requirements are as per 520.TY1

LTR. NO. 0766/T-90/TRACID/IT: 11/04/05

DRAWINGS ENCLOSED ARE CONFIDENTIAL  
 UNAUTHORISED REPRODUCTION IS PROHIBITED  
 TO INVITE PENAL ACTION UNDER THE INDIAN  
 OFFICIAL INFORMATION ACT.  
 BY ORDER St. GM. HVP

DRG. INDIANISED BASED ON RUSSIAN ORIGINAL ISSUE -NIL

359  
 SUPPLY CODE U-01-14  
 D90210  
 F-104  
 45  
 SIZE A2

PILOT SAMPLE SHOULD BE APPROVED BY A H S P BEFORE BULK PRODUCTION.

EST. WT. (Kg) 3.25	TO BE STAMPED OR MARKED WHERE INDICATED THUS # ( LETTERS)
ALL SHARP EDGES AND CORNERS TO BE REMOVED UNLESS OTHERWISE STATED MACHINED CORNERS TO HAVE R OUTSIDE R INSIDE EQUIVALENT CHAMFERS ARE PERMISSIBLE.	

APFD Date 31-5-04	SCALE: 1:1 DIMENSIONS IN mm TOLERANCE ON DIMS UNLESS OTHERWISE STATED IS: 2102-69 ALL THREADS TO CONFORM TO	CONTROLLERATE OF QUALITY ASSURANCE (HEAVY VEHICLES) AVADI	TITLE: PIN ASSY.
ISSUE	DATE	NATURE OF AMENDMENTS	D S CAT NUMBER
			DRAWING NUMBER 219.35cb-167Cb