

M 4006

NOTES:

- FINISH  $\sqrt{16}$  EXCEPT AS NOTED.
- BREAK EDGES 0.076 + 0.305 UNLESS OTHERWISE SPECIFIED.
- HEAT TREATMENT: FOR 6150: HEAT AT 843- 871° C. OIL QUENCH, TEMPER ONE HOUR MINIMUM TO HARDNESS SPECIFIED (RH C45-51). FOR 4340: HEAT AT 815.3 - 843° C. OIL QUENCH, TEMPER ONE HOUR MINIMUM TO HARDNESS SPECIFIED (RH C45-51).
- FINAL PROTECTIVE FINISH: FINISH 5.3.1.2 OR 5.3.2.2 OF MIL-STD-171.
- ASME Y14.5M-1994 APPLIES.
- MATERIAL: ALLOY STEEL, SHEET AND STRIP, ASTM A506, GRADES 6150, 4340, 4140; ALLOY STEEL, BARS, COLD FINISHED, ASTM A331, GRADES 6150, 4340, 4140. ALTERNATE MATERIALS: ALLOY STEEL, BARS, HOT WROUGHT, ASTM A322, GRADES 6150, 4340, 4140; ALLOY STEEL, PLATES, ASTM A829, GRADES 6150, 4340, 4140; ALLOY STEEL, SHEET, STRIP, PLATE, AMS 6359 (GRADE 4340); ALLOY STEEL, SHEET, STRIP, PLATE, AMS 6395 (GRADE 4140); ALLOY STEEL, SHEET, STRIP, PLATE, AMS 6455 (GRADE 6150).

REVISIONS				
ZONE	REV.	DESCRIPTION	DATE	APPROVED
	A	CREATE DRAWING	3/23/2015	G. HERSBERGER

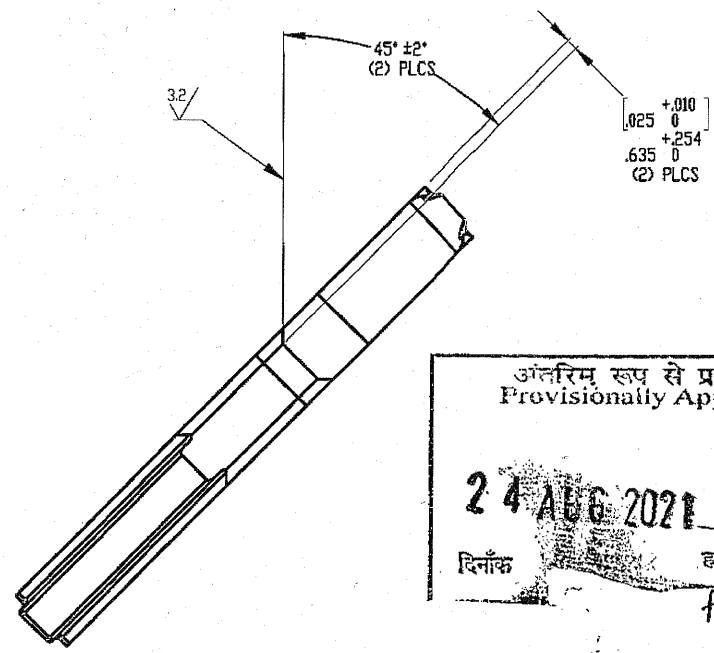
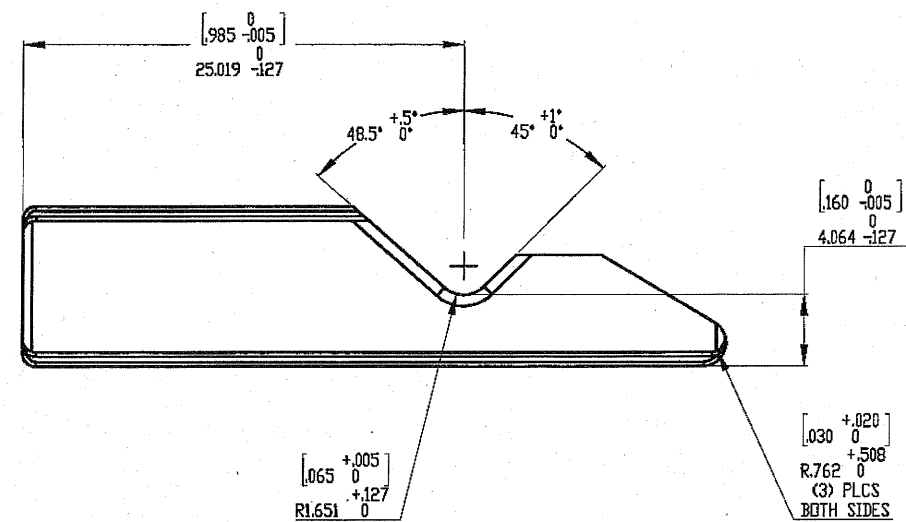
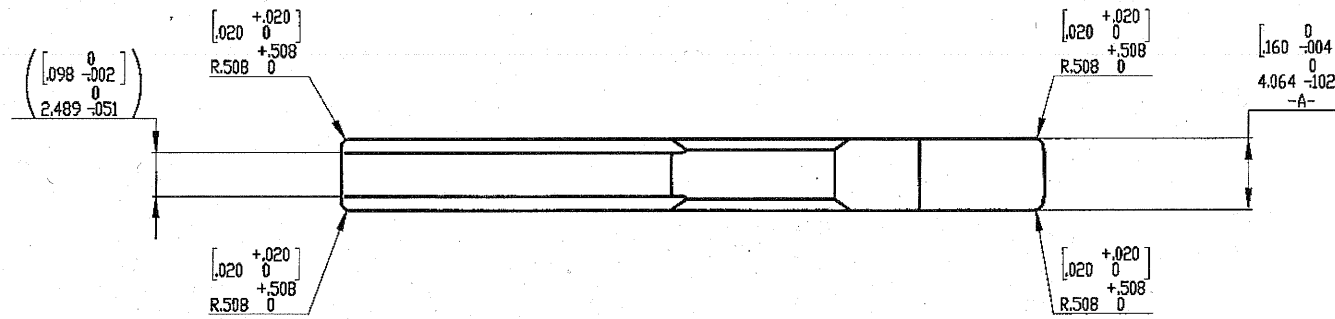
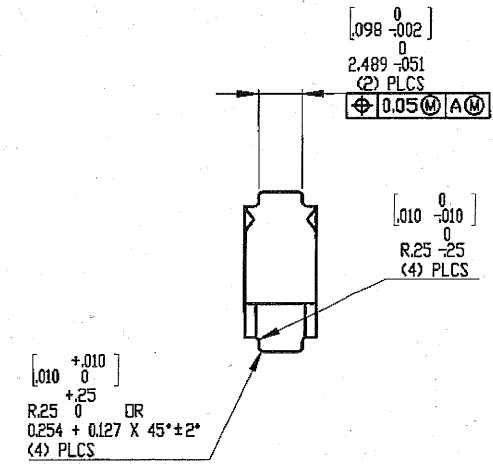
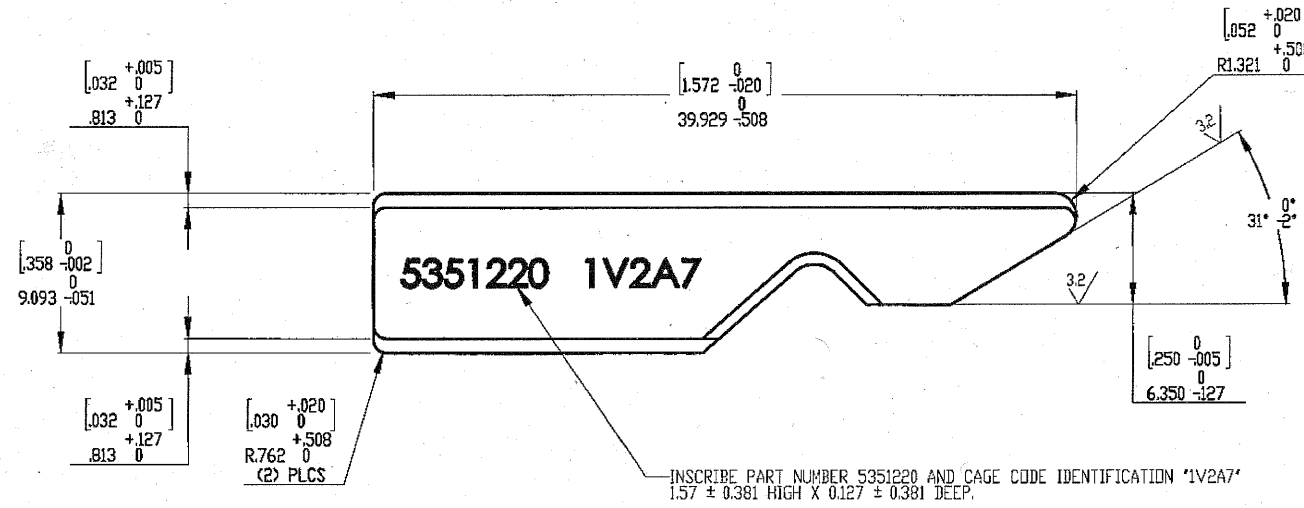

UN CONTROLLED COPY  
 CERTIFIED CORRECT COPY OF APPROVED  
 DRAWINGS AT THIS DATE 23.03.2021  
 DESIGN & DRAWING OFFICE,  
 ORDNANCE FACTORY, TIRUCHIRAPPALI - 620 016.

अंतरिम रूप से प्रमाणित  
 Provisionally Approved  
 24 AUG 2021  
 दिनांक हस्ताक्षर/Sig  
 for (mod/APP)

ITAR CONTROLLED		UNLESS OTHERWISE SPECIFIED		DATE		DHIO ORDNANCE WORKS, INC.	
THIS DOCUMENT IS CONTROLLED	EXCEPT WHERE SHOWN OTHERWISE	ALL DIMENSIONS ARE IN INCHES	DRAWN	PKD	12/08/16	SIZE	REV
UNLESS OTHERWISE SPECIFIED	UNLESS OTHERWISE SPECIFIED	UNLESS OTHERWISE SPECIFIED	FRANCIS			D	A
UNLESS OTHERWISE SPECIFIED	UNLESS OTHERWISE SPECIFIED	UNLESS OTHERWISE SPECIFIED	FRANCIS			5351220	
UNLESS OTHERWISE SPECIFIED	UNLESS OTHERWISE SPECIFIED	UNLESS OTHERWISE SPECIFIED	FRANCIS				
UNLESS OTHERWISE SPECIFIED	UNLESS OTHERWISE SPECIFIED	UNLESS OTHERWISE SPECIFIED	FRANCIS				
UNLESS OTHERWISE SPECIFIED	UNLESS OTHERWISE SPECIFIED	UNLESS OTHERWISE SPECIFIED	FRANCIS				
UNLESS OTHERWISE SPECIFIED	UNLESS OTHERWISE SPECIFIED	UNLESS OTHERWISE SPECIFIED	FRANCIS				
UNLESS OTHERWISE SPECIFIED	UNLESS OTHERWISE SPECIFIED	UNLESS OTHERWISE SPECIFIED	FRANCIS				
UNLESS OTHERWISE SPECIFIED	UNLESS OTHERWISE SPECIFIED	UNLESS OTHERWISE SPECIFIED	FRANCIS				
UNLESS OTHERWISE SPECIFIED	UNLESS OTHERWISE SPECIFIED	UNLESS OTHERWISE SPECIFIED	FRANCIS				
UNLESS OTHERWISE SPECIFIED	UNLESS OTHERWISE SPECIFIED	UNLESS OTHERWISE SPECIFIED	FRANCIS				

D 5351220 1A