

ISS C A AA C SS IC DRG No. 0204 0304 0001 0004 0013 00DA

GENERAL TOL. : FINE / MEDIUM / COARSE CLASS TO IS: 2102 DRG. CONVENTIONS CONFIRM TO INDIAN STANDARDS DIMENSIONS ARE IN mm UNLESS OTHERWISE STATED.

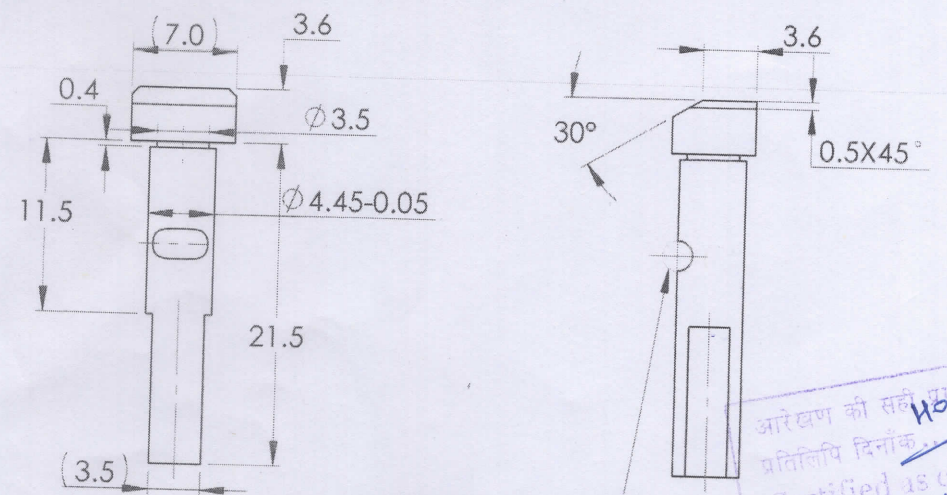

Ø2.0 TO BE DRILLED IN CONJUNCTION WITH SLIDE COCKING HANDLE; LLE DRG NO 0805 07 01 00 01 002 00XA

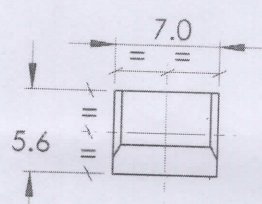

अरेक्षण की सही प्रतिलिपि दिनांक...  
 Certified as copy of drg. on...  
 क. कविशाला प्रसाक  
 Jr. Works  
 STANDARD

- NOTES:**
- 1) REMOVE ALL SHARP EDGES AND BURRS
  - 2) HARDNESS: 325-375 HV
  - 3) IF THE COMPONENT IS TO BE MANUFACTURED THROUGH MIM ROUTE, REFER ARDE SPECN NO: DRDO/ARDE/MIM/TSP/051/2019.
  - 4) ALT. PROTECTIVE COATING: PHOSPHATED TO SPECN. IS:3618-1966, CLASS 'B'

Sr. No.	DATE	AUTHORITY	BRIEF RECORD	ZONE	CD	GO
DRN: ANKIT	07/03/2019	<i>ANKIT</i>	MATERIAL:			
SIGN: <i>ANKIT</i>		CHECKED	STEEL TO IS: 5517-1993, Gd-40Ni6CrMo3			
DATE: 07/03/2019			PROTECTIVE FINISH:			
APPD.	07/03/2019	FOR DIRECTOR	ELECTROLESS NICKEL-BORON NITRIDE (NiBN) COATING AS PER ARDE SPECN. NO: ARDE/SA/2016/COATING-02			
SEALED DATE:			TITLE:			
SHEET SIZE: A4	EST. MASS		<b>STUD COCKING HANDLE</b>			
SCALE: 1:1	3.41 gm					
DESIGN AUTHORITY						
<b>ARDE</b>						
PUNE 411021						
DRG No.	0204	03	04	00	01	013
IC	SS	S	AA	A	C	SST
JVPC	PART No.	DS CAT No.	AHSP			