

4 NOS. OF STEELWIRE DIA 1.219 (8SWG)
TO BE TWISTED WITH BRISTLE

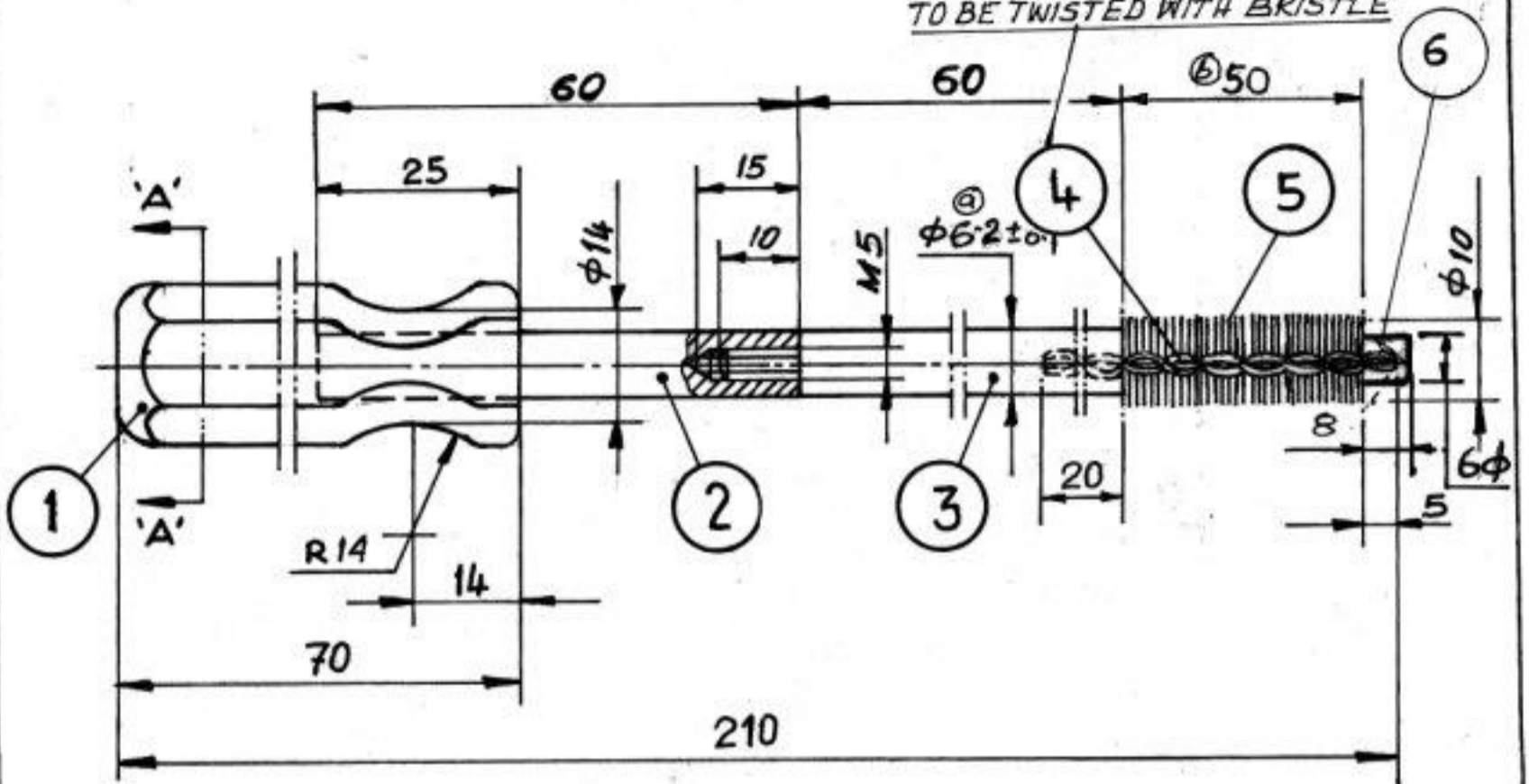

- NOTE:**
- i) ITEM NO. 6 TO BE MOULDED IN ASSY COND.
 - ii) THE COLOUR OF ITEM NO. 1 SHOULD BE MILK WHITE
 - iii) NO. OF BRISTLE OF ITEM NO. 5 SHOULD BE 45.

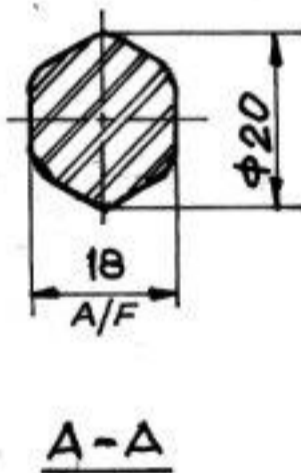

6	1	NYLON	CAP
5	1	NYLON	NO 22/23 (SWG) BRISTLE
4	1	STAINLESS STEEL	WIRE NO. 18 SWG
3	1	STAINLESS STEEL	ROD FRONT
2	1	STAINLESS STEEL	ROD REAR
1	1	ABS	MOULDED HANDLE
ITEM NO.	NO. OFF	MATERIAL	DESCRIPTION

LIST OF PARTS

Schedule No.	Comp. BARREL FOR	Store Drg. No.
Scale :- 1:1	J.O.F. 0.32" PISTOL	M-8195
Projection Third Angle		

BORE CLEANING BRUSH

DRG. NO. M-9106A

DIMNS. ARE IN mm.

DT.&SG. 21.9.98 a) WIRE ϕ CHANGE b) MATL. FOR ITEM NO 3E & CHANGED. c) ITEM NO-6 ADDED d) WAS-30 e) WAS-7.5	Schedule No.	Traced By	Checked By	Approved By	M/C:-	NO. OF SHEETS 1
	Scale :- 1:1	Projection Third Angle	Drawn By <i>Shreeha</i>	30.3.97	10/4/98	
	APPROVED BY			G&S FY. COSSIPORE		
	AMENDMENTS	DATE :-	SIGN	SHEET NO. 1		

DRG AMENDED VIDE MEMO NO - MKTG/0.32" PIS/GENL/98 dt 15.9.98.