

4 3 2 1
D S CAT No.

5120-409529

DRG. CONVENTIONS CONFORM TO IS: 696

DIMNS ARE IN MM UNLESS OTHERWISE STATED

TOLERANCES FOR UNTOLERANCED LINEAR DIMENSIONS

ABOVE UP TO	- 6	6 30	30 120	120 315	315 1000	1000 2000	2000 4000	4000 -
TOL.	±0.1	±0.2	±0.3	±0.5	±0.8	±1.2	±2	±3

TREATMENT- HRD & TEMP. RC-45-50

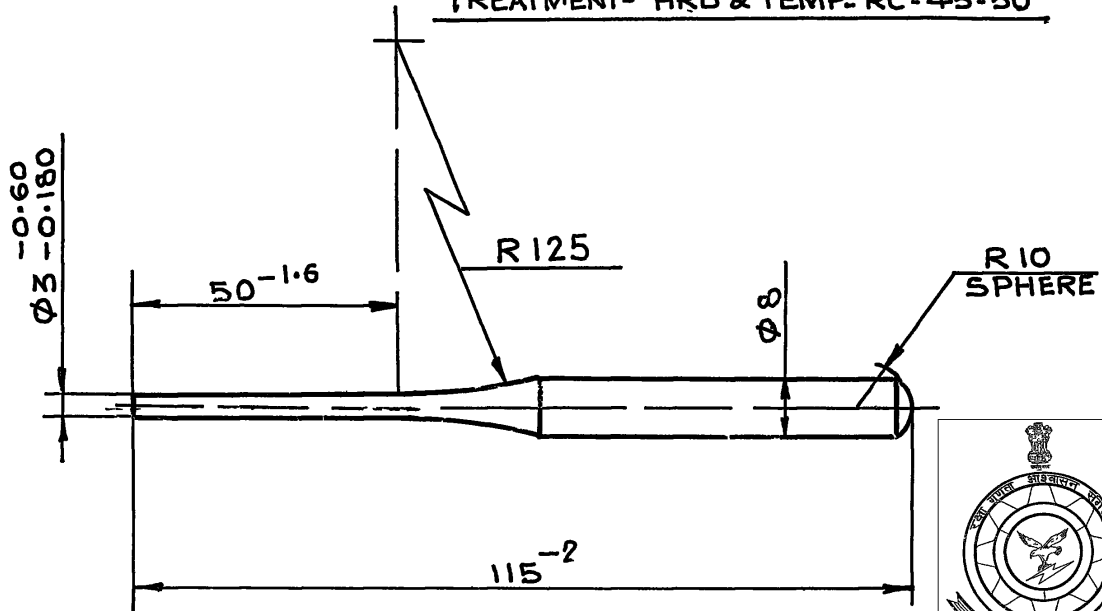

NOTES:-

1. SHARP EDGES SHOULD BE BLUNTED TO R=0.4
2. SUBJECT TO AMENDMENT BASED ON SAMPLE TO BE APPROVED BY A HSP BEFORE COMMENCEMENT OF REGULAR PRODUCTION.

PROTECTIVE FINISH:-

PHOSPHATING AS PER SPEC. JSS-0465-10, 1988. IMPREGNATION WITH DUNLOP ADHESIVE-778 OR APC6T0 SPEC. JSS-8040-12 AND NIGROSINE TO SPEC. JSS-1036 ONE LAYER.

BASED ON OFT DRG.No.C 9041

24-12-09	19175-W		D S CAT No ADDED & NOMENCLATURE AMENDED			CQA(W) JABALPUR
13-10-94	18845-W		HINDI-NOMEN ADDED			DRN-
30-9-95	18175-W		REF OF SPEC IS 5517 AMENDED.			CHD-
25-11-91			NEW POLY-NEG PREPARED			TCD- <i>P. Singh</i>
DATE	AUTHORITY	ZONE	NATURE	SIG AHSP	SIG DO	CHD- <i>G.P. Shukla</i>
AMENDMENTS						
DRG. SEALED:- DC(1) No. 16962-W						
DT. 24.10.90 DO CQA(W)						
SCALE- NTS			ESTD MASS-	DATE		
MATE:- STEEL, DESIG. 50C8, IS: 5517-1993						
ASSY DRG.						
DRIFT PIN ड्रिफ्ट पिन						ICM 2114
D S CAT No.						5120-409529