

SECTION B-B
SCALE 5.000

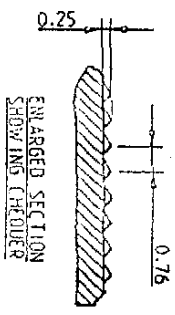

SECTION D-D
SCALE 10.000

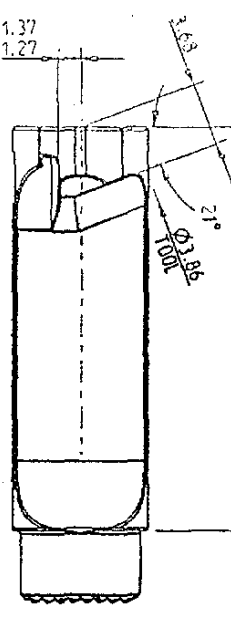
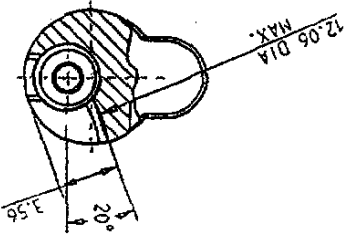

SECTION A-A

MATERIAL : AISI / SAE 4340, NIM 4340 OR EQUIVALENT
HARDNESS : 82-87 HR 15N
SUPPLY CONDITION : MANGANESE PHOSPHATED

NOTE:- 1. ALL DIMENSIONS ARE IN MM.
2. GENERAL TOLERANCES ARE AS PER ISO 2768 (M).

HOS / MPM
CERTIFIED COPY OF
DRG/LAYOUT/GALG+ SCHEDULE
AT THIS DATE...S...R.G.- 2017
RIFLE FACTORY ISHAPORE

CATCH MAGAZINE
(THROUGH MIM ROUTE)

DRG. REF. NO. - D.S.CAT 1005-003148

DRG. NO. - RFLSK 10123

PAGE-1/3

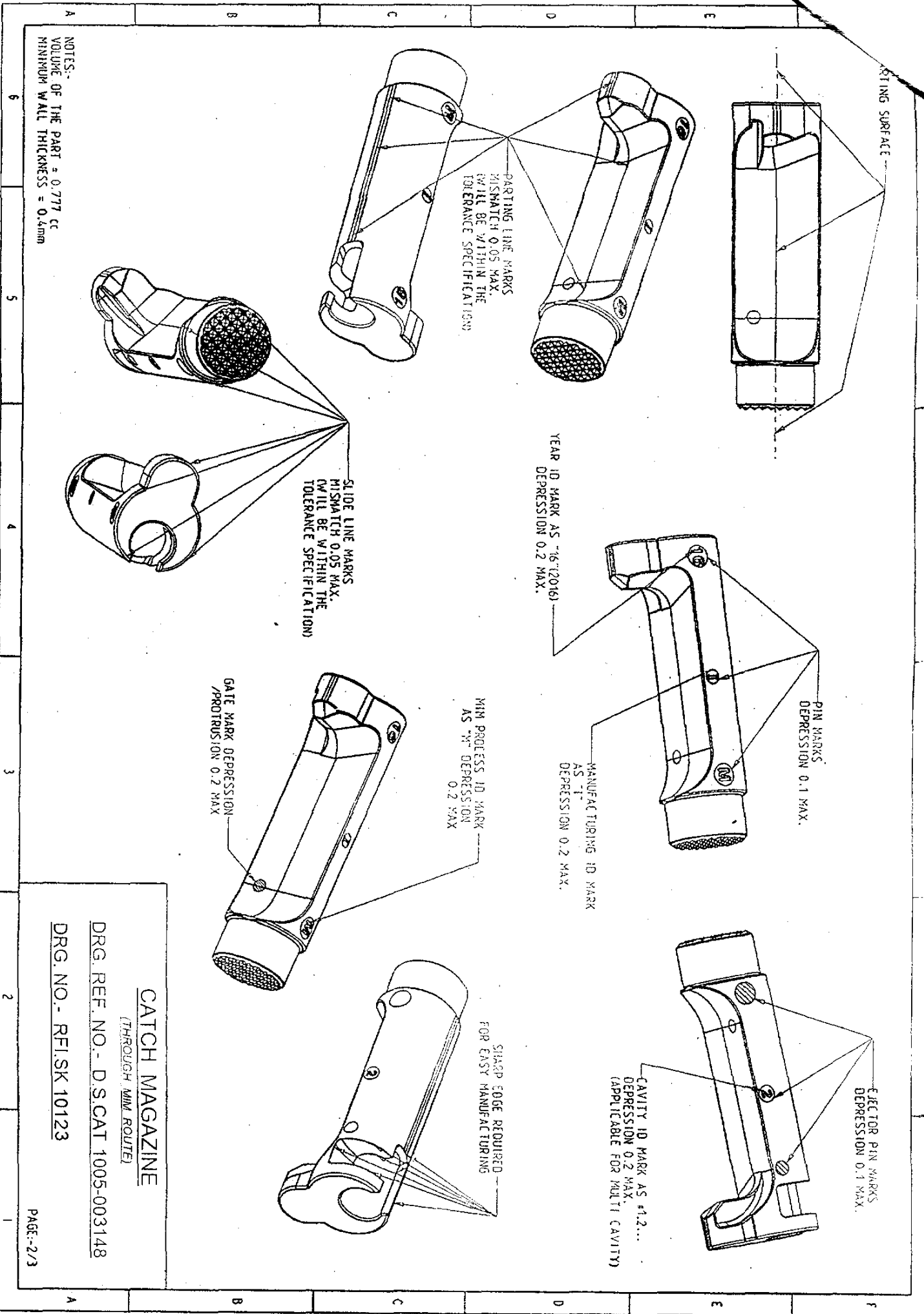

CASTING SURFACE

PARTING LINE MARKS
MISMATCH 0.05 MAX.
(WILL BE WITHIN THE
TOLERANCE SPECIFICATION)

YEAR ID MARK AS "16"(2016)
DEPRESSION 0.2 MAX.

SLIDE LINE MARKS
MISMATCH 0.05 MAX.
(WILL BE WITHIN THE
TOLERANCE SPECIFICATION)

PIN MARKS
DEPRESSION 0.1 MAX.

MANUFACTURING ID MARK
AS "1"
DEPRESSION 0.2 MAX.

MIM PROCESS ID MARK
AS "M"
DEPRESSION
0.2 MAX

GATE MARK DEPRESSION
/PROTRUSION 0.2 MAX

EJECTOR PIN MARKS
DEPRESSION 0.1 MAX.

CAVITY ID MARK AS #12...
DEPRESSION 0.2 MAX.
(APPLICABLE FOR MULTI CAVITY)

SHARP EDGE REQUIRED
FOR EASY MANUFACTURING

NOTES:-
VOLUME OF THE PART = 0.777 CC
MINIMUM WALL THICKNESS = 0.4mm

CATCH MAGAZINE
(THROUGH MIM ROUTE)

DRG. REF. NO. - D.S.CAT 1005-003148

DRG. NO. - RFL/SK 10123

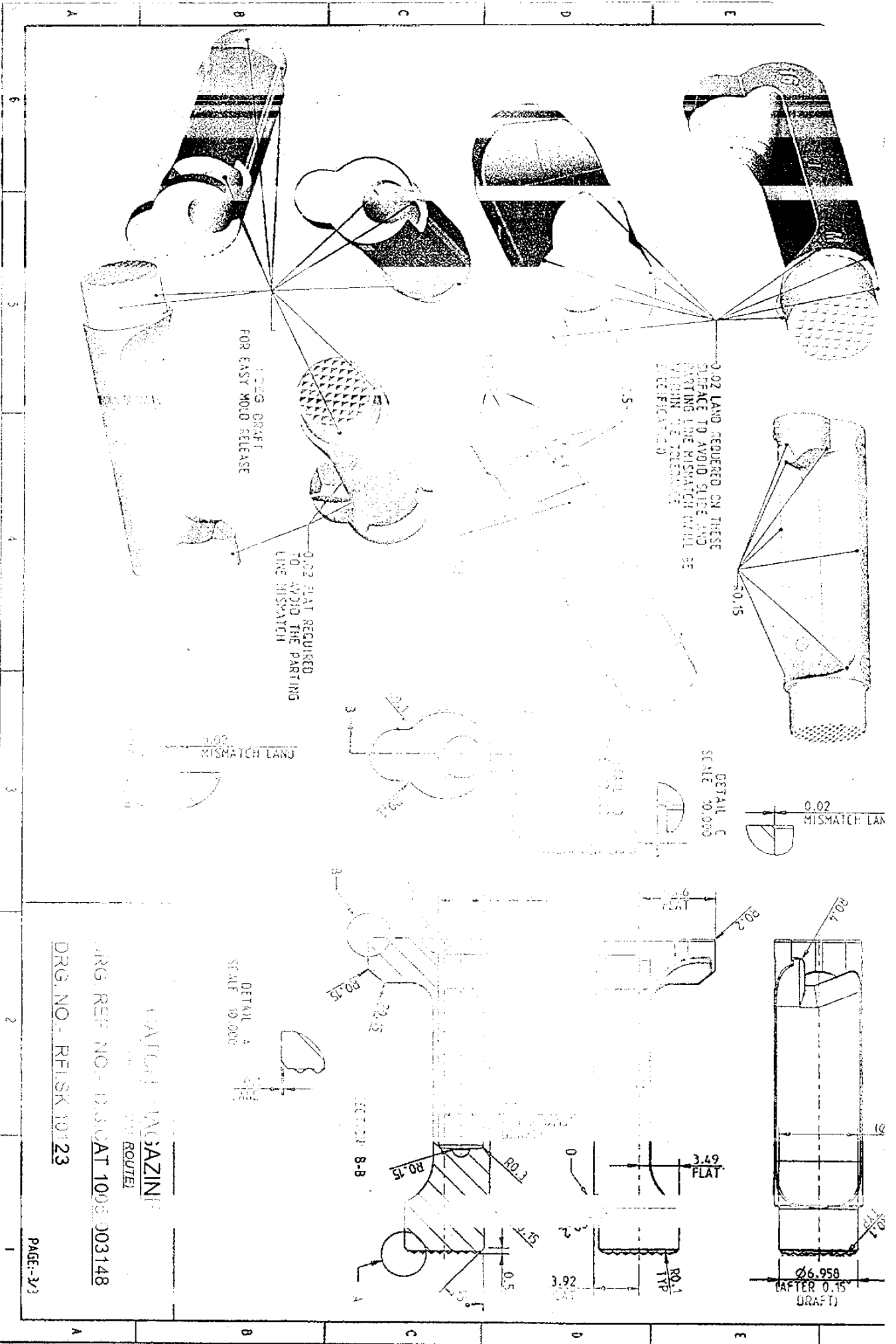

MAGAZINE (SEE ROUTE)

DRG. REF. NO. - D.S. CAT 1005 003148

DRG. NO. - REISK 10123