

DIMENSIONS ARE IN mm.

UNTOLERATED DIMNS. AS PER IS : 2102 (MED)

SHARP CORNERS SHOULD BE BLUNT TO R 0.5

PROTECTIVE FINISH : PHOSPATED TO SPECIFICATION. JSS : 0465-01-1988

CLASS-I (ACCELERATED) OIL FINISH.

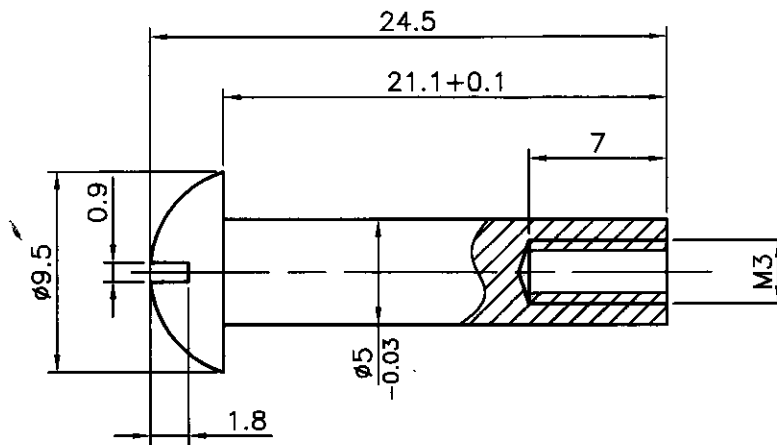

MATERIAL: IS: 1875-1992 CLA.4 DESIG. 45-C8
(OR) BS:970, PART-1, 1983 GRADE 080M40.

ALT. MATL: En 9

HARDNESS:- 24-32 HRC

QTY. REQD:- 2 Nos. PER GUN.

PART NO.	DESCRIPTIONS	NO OFF	MATERIAL	TREATMENT	REMARKS
	SIGNATURE & DATE.	SUB: PIN TRIGGER			SCALE NTS
	TRACED	FOR: REAR FRAME & TRIGGER MECH. GROUP.			STORE DRG.NO.
	DRAWN <i>[Signature]</i>	OF: 38mm MSL			-
	CHECKED <i>[Signature]</i>	DES.REF.NO.			OPERATION NO.
	HOS/D&DO <i>[Signature]</i>	DRG. No.: 33P 3067			-
	NODAL OFFICER FOR MSL <i>[Signature]</i>	 ORDNANCE FACTORY TIRUCHIRAPPALLI-16.			SHEETS: 1
	OFFICER/D&DO <i>[Signature]</i>				SHEET No.: 1
AMENDMENTS	SIG. & DATE	APPROVED ON. 22/12/2014			