

UN CONTROLLED COPY
 CERTIFIED CORRECT COPY OF APPROVED
 DRAWINGS AT THIS DATE: 01/13/21
 DESIGN & DRAWING OFFICE
 ORDNANCE FACTORY, TRIRUCHIRAPPALLI-620 016.

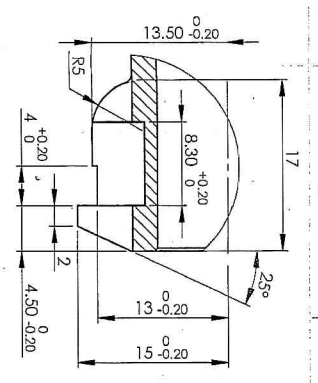

DETAIL K

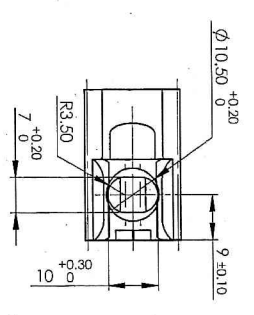
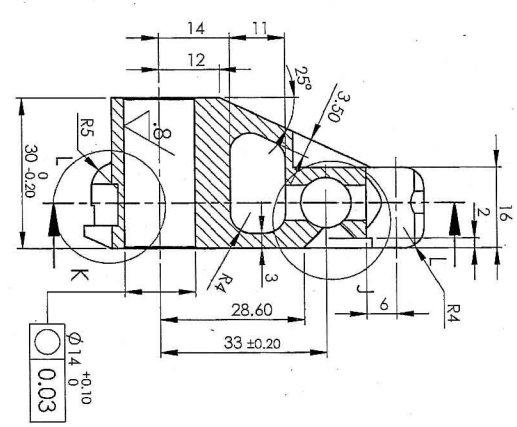
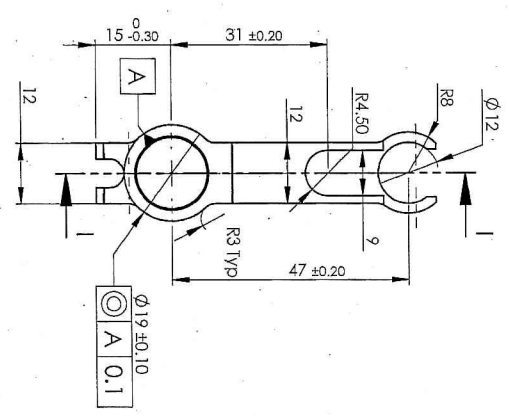

SECTION H-H

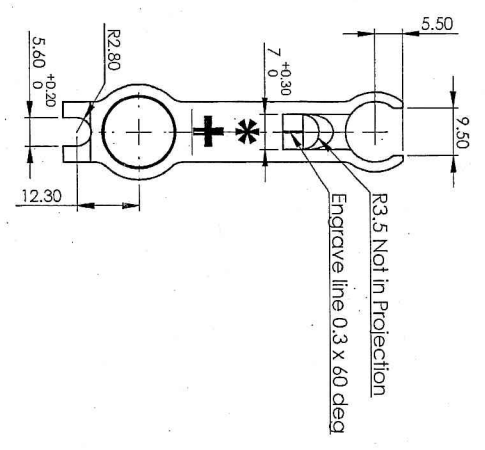

SECTION I-I

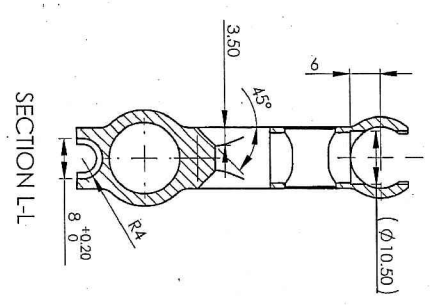

SECTION L-L

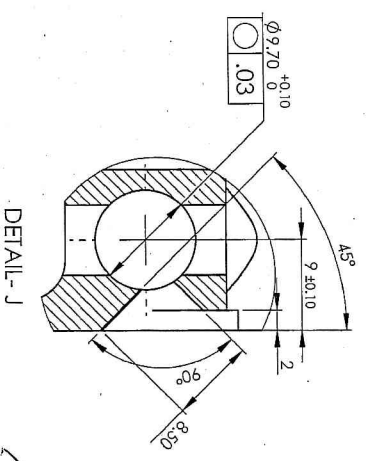

DETAIL J

[Signature]
 HGS/FSS

MARKING:-
 * MANUFACTURER CODE
 + BATCH/YEAR OF MANUFACTURE
 ENGRAVING DEPTH 0.1 mm & HEIGHT 2.5 mm.

Material: Steel
 BS:970 Pt.1 1983 Gr 709 M40 (En19)
 BS:970 Pt.1 1983 Gr 708 M40 (En19A)
 BS:970 Pt.1 1983 Gr 817 M40 (En24)
 Hardness: 290-350 HV
 Protective Finish:
 Phosphating to Specn.
 JSS: 0465-01-1994 Class II Oil Finish
 Untolerated Dimens. as per IS:2102 (MED)

Material for Casting:-
 BS:3146 PART-1, 1974 Class:5, Grade:A
 Non Stressed Component
 Radiographic Test as per ASTM-E-192

Acceptance Standard:-
 Gas hole & Foreign Material: Level-3
 Shrinkage (All Types) : Level 3
Note:- for Casting
 Tolerance as per IS:11166 Class-1
 Flatness Tolerance : ±0.1 / 25.4mm
 Casting Radius 0.5 mm

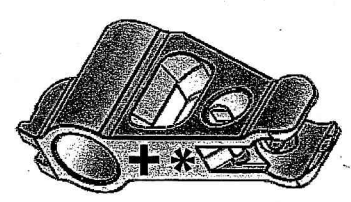

AMENDMENTS & DATE	SIG. & DATE	APPROVED ON : 29/04/2021	SIGNATURE & DATE DRAWN CHECKED OFFICER/PRODN. DIV/OFFICER/D&DO	SUB: Front Sight Block PWB(FS) FOR: Barrel Assy OF: TRICHY ASSAULT RIFLE DES. REF. NO. K1207* DRG. No.: TEND-2668 ORDNANCE FACTORY TRIRUCHIRAPPALLI-16.	SCALE NTS QPG 1 SHEETS: 1 SHEET No.: 1
-------------------	-------------	--------------------------	--	--	---