

DRG CONFIDENTIAL

DRG. NO. SK-6531/TE

COPY No. 1

D.A. NO.

$\sqrt{Rz} 40 (\checkmark)$

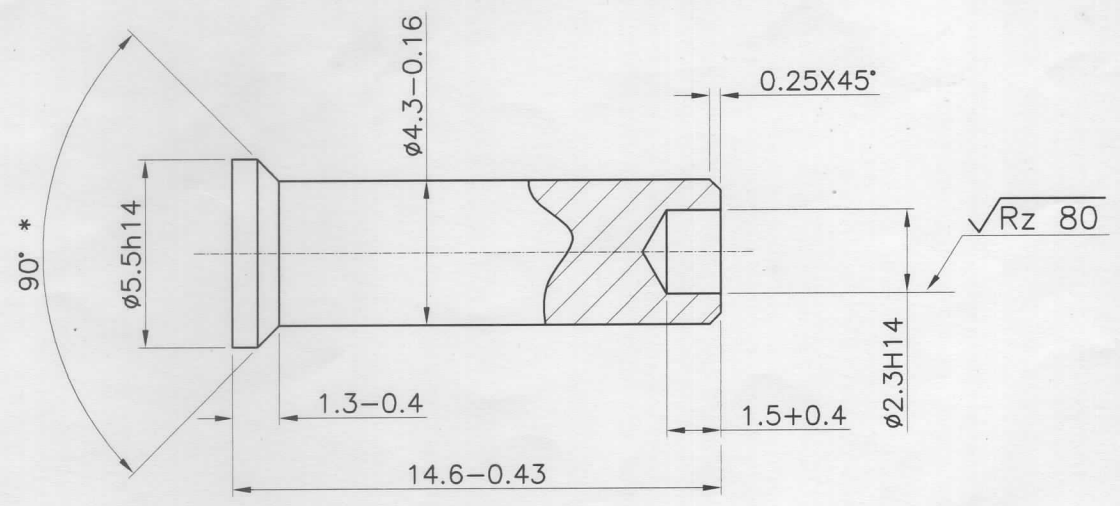

आवृत्त की री प्रमाणित
 प्रतिलिपि दिनांक... 21/08/23
 Certified as correct copy
 of drg. on... 21/08/23
 Mr. K. S. Soni
 Jr. Works Manager
 डी.पी.ओ.
 DDO

MATL.:- Steel 35 GOST 1051-73
Weight.:-1.2 g

- 1 *Dimension to be ensured by tool.
- 2 Unspecified tolerance according to 6745-1.CDTY/E2.
- 3 Allowed to be produced by wire upsetting
 $\phi 3.9-25$ GOST 5663-79.
- 4 Coating is Chem. Phos. chr/impreg. with $\phi 4$ glue
 GOST 12172-2016 with nigrosine grade A GOST 9307-78.

7.62X39mm AR-SAF
Pin

DRAWN.	TRACED	CHECKED
S.P.SONI		
DATE	10.08.2023	
APPROVED	HOS/DDO	
DRAWING NO.		
SK-6531/TE		
SHEET 1 OF 1		

SCALE
5:1

SMALL ARMS FACTORY
KANPUR