

DRAWING INDIANISED BASED ON RUSSIAN ORIGINAL ISSUE - 8

DRAWING NUMBER
350-144

20/ (✓)

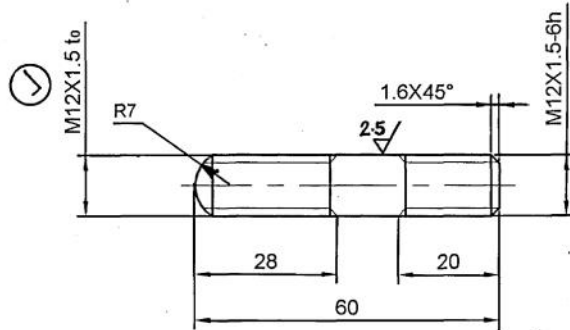

1. Inspection group IV as per TT-11.
2. HRC 28...35.
3. Technical requirement for thread to be carried out as per standard 82021-00.
4. Dimension without deviation and other T.R to be carried out as per standard 88052-00.
5. Coating to be done with cadmium-3 micron, Chromium 1 micron as per instruction ИЛ-569-84 with subsequent removal of hydrogen embrittlement.
6. It is allowed to make threads by rolling with diameter of unthreaded portion within the limits of mean diameter of the threads.
7. Repair size dimensions are added where indicated thus based on overhaul specification part III repair drawings.

(A)

SL. No	R	REMARKS
1.	M14 X 1.5 to	ALL OTHER CONDITIONS AS PER STD. DRG.
2.	PCD = 13.026 ^{+0.170} _{+0.095}	

(80) EQUIVALENT MATERIAL
STEEL 709 M40 (EN 19) TO BS: 970/
40 Cr 4 Mo 3 TO IS: 1570

PILOT SAMPLE SHOULD BE APPROVED BY A H S P BEFORE BULK PRODUCTION.

EST. WT. 0.05 TO BE STAMPED OR MARKED WHERE INDICATED THUS # (LETTERS)

ALL SHARP EDGES AND CORNERS TO BE REMOVED UNLESS OTHERWISE STATED MACHINED CORNERS TO HAVE R OUT-SIDE R INSIDE EQUIVALENT CHAMFERS ARE PERMISSIBLE.

			DRN		MATERIAL :- ROUND BAR	USED ON :-
			CHD		GOST 7417-75	Cb 3301-15-30
			APPD		38XA GOST 1051-73	
			DATE	03-01-08	CONTROLLERATE OF QUALITY ASSURANCE (HEAVY VEHICLES)	
			SCALE:-	1:1	AVADI	
			DIMENSIONS IN mm		TITLE :-	STUD M12x60
			TOLERANCE ON DIMNS UNLESS OTHERWISE STATED IS : 2102 - 69			
			ALL THREADS TO CONFORM TO		D S CAT NUMBER	DRAWING NUMBER
			ISSUE	DATE		350-144

F-153
64
74

SIZE A3