

TECHNICAL SERVICES SECTION  
 वाहन निर्माण, जबलपुर  
 Vehicle Factory, Jabalpur  
 प्रमाणित तथा प्रतिवर्षि  
 CERTIFIED CORRECT COPY  
 का जारी/Issued to JWM/vmm  
 दि/On 28/08/21  
 का कार्ट प्रबंधक/टी एस एच  
 JWM/TCC

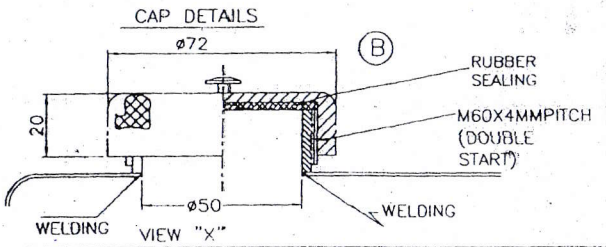
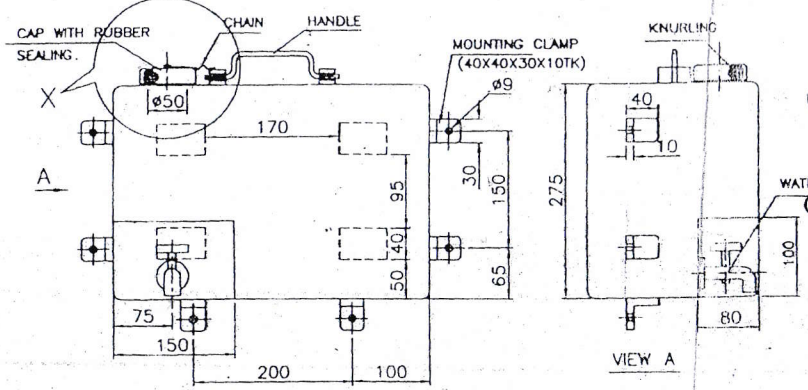
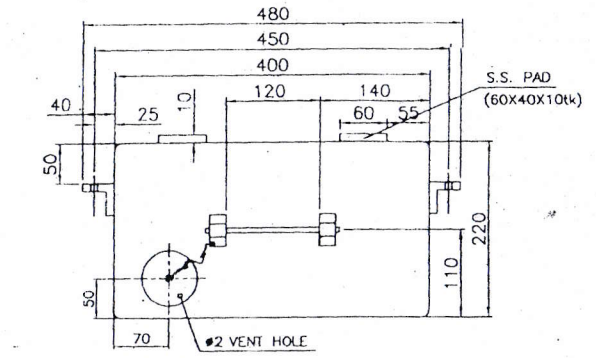

- NOTE:
1. ALL DIMENSIONS ARE IN MM.
  2. UNSPECIFIED LIMIT DEVIATIONS ARE  $\pm 1$ mm
  3. GOOD QUALITY FOOD GRADE RUBBER SEALINGS TO BE USED AT CAP AND AT WATER TAP FOR LEAK PROOF.
  4. ROUND OFF ALL CORNERS WITH R10mm.
  5. TANK SHOULD BE LEAK PROOF & RUST PROOF.
  6. GOOD QUALITY WATER TAP TO BE USED.
  7. COMPLETE TANK SHOULD OF STAINLESS STEEL.
  8. PILOT SAMPLE TO BE SUPPLIED FOR APPROVAL/ SUGGESTIONS BEFORE GOING FOR BULK PRODUCTION.
  9. WATER TAP POSITION TO BE WITHIN THE LIMITS OF OUTER DIMENSIONS.
  10. FOUR STAINLESS STEEL PADS ARE TO BE WELDED TO THE TANK AS SHOWN IN THE DRAWING.
  11. SUITABLE HANDLE IS TO BE PROVIDED AND IT SHOULD BE FREE TO HANDLE AND TO FOLD AND UNFOLD.
  12. CAPACITY OF THE TANK SHOULD BE NOT LESS THAN 21 Ltrs.
  13. THICKNESS OF THE TANK CASING SHEET SHOULD BE 1mm. MIN.
  14. OUTSIDE FINISHING OF THE TANK SHOULD BE GOOD.
  15. PLEASE ASK IF ANY DOUBT. (B)

- (C) 16. WELDING ROD SHOULD CONFIRMS TO AISI-316 OR Gr. 04 Cr17Ni12 Mo 2. TO IS: 6911-
- (D) 17. PLUNGER/PUSH TYPE WATER TAP SHOULD BE PROVIDED.

(D)	04-3-19	NOTE No. 17 ADDED	Jwm/joc AD/ODL	QTY./MTR	01
(C)	26-11-07	NOTE No. 16 ADDED.		USED ON	
(B)		CAP DETAILS ADDED & IN NOTE POINT No. 15 ADDED.			
(A)		CAPACITY OF THE WATER TANK IS INCREASED TO 21 LTRS. MOUNTING BRACKETS ARE SHOWN			

DRG. NO: 640-01-1450-1/D

ORDNANCE FACTORY MEDAK

DRINKING WATER TANK

MATERIAL: STAINLESS STEEL TO SPECN.: AISI-316 (OR) IS: 6911 GR. 04Cr17Ni12Mo2

THIRD ANGLE PROJECTION

APPRO. (ENGR)	USER (ENGR)	CHKD. (AB)	DRWN. (ENGR)
NAME	NAME	NAME	NAME
SIGN	SIGN	SIGN	SIGN
DATE	DATE	DATE	DATE

PROPRIETARY  
 THE INFORMATION CONTAINED IN THIS DOCUMENT IS PROPRIETARY TO ORDNANCE FACTORY, MEDAK (OFMK). ANY USE, REPRINTING, ASSIGNMENT OR DISCLOSURE IN WHOLE OR IN PART IS SUBJECT TO THE PRIOR WRITTEN CONSENT OF THE GENERAL MANAGER, ORDNANCE FACTORY, MEDAK  
 DATE: D.O/MOS