

DRG. NO: 720 F/ALT

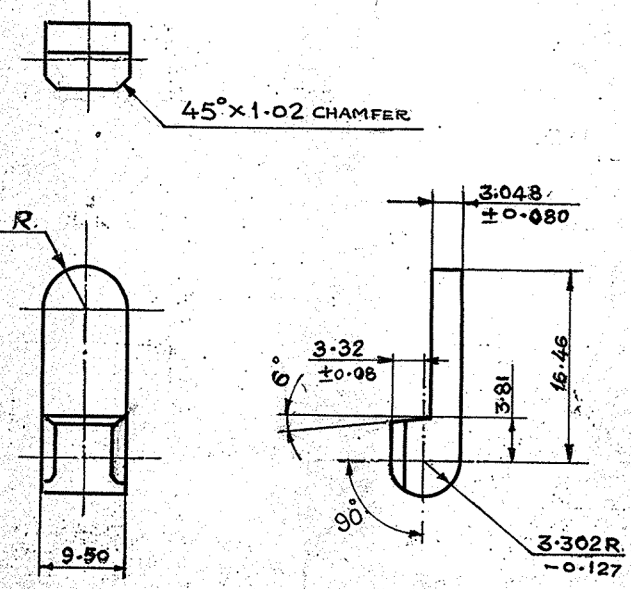

RADIOGRAPHIC TEST AS PER ASTM-E-192 GRADE B

- NON-STRESSED COMPONENTS:-  
 100% FOR ADVANCE SAMPLES  
 FOR BULK COMPONENTS, 5% OF EACH CAST/HEAT SHOULD BE  
 SUBJECTED TO RADIOGRAPHY FOR GR. B CASTINGS.
- RADIOGRAPHIC ACCEPTANCE LIMIT:
- |                       |         |
|-----------------------|---------|
| GRADE B CASTINGS      |         |
| GAS HOLES             | LEVEL-5 |
| FOREIGN MATERIAL      | LEVEL-5 |
| SHRINKAGE (ALL TYPES) | LEVEL-3 |

VISUAL EXAMINATION:-

AS PER IS: 2500-PT.I-1992 INSP. LEVEL III  
 AQL 15  
 INVESTMENT CASTINGS ARE TO BE  
 TESTED AS PER SPECN. NO.  
 MQA-1/QA/12 dt. 5.5.94

VETTED FOR MATERIAL ONLY

*[Signature]* 18/11/93

Principal Scientific Officer,  
 Quality Assurance Officer,  
 For Senior Quality Assurance Officer,  
 Senior Quality Assurance Estt. (Arms),  
 Tiruchirappalli - 600 016.

TOLERANCE OF THE INVESTMENT CASTING COMPONENTS:-  
 WHERE TOLERANCE NOT GIVEN GENERAL TOLERANCE I.S. 11166 CLAUSE I  
 TO BE FOLLOWED. EXCESS MATERIAL FOR MACHINING IS ALLOWED.  
 ABSENCE OF MATERIAL IS NOT ACCEPTABLE. REJECTION AT OUR  
 END FOR WANT OF MATERIAL IS NOT ACCEPTABLE.

COMPONENT TO BE IN THE NORMALISED CONDITION.

MATERIAL:- BS 3146 PT.1 CLA.-12, GR. A  
HARDENED AND TEMPERED TO  
ACHIEVE HARDNESS 400-475 HV.

DIMENSIONS ARE IN MM.

*[Signatures]*

INVESTMENT CASTING STUDY TEAM

		AS STATED ABOVE.			
ITEM NO.	DESCRIPTION	NO OFF	MATERIAL	TREATMENT	REMARKS
①	SIGNATURE & DATE		LEAF BACKSIGHT (INVESTMENT CASTING)		SCALE: 2:1
DRAWN	<i>[Signature]</i>		REF:- D.S.CAT NO. 1005-001602.		STORE DRG NO 1CR 1330
CHECKED	<i>[Signature]</i>		DES. REF NO:		OPERATION NO
TRACED			DRG. NO: TEND-720 F/ALT		
TRACING CHECKED			I/C DESIGN & DRG. OFFICE		SHEETS: 1
			ORDNANCE FACTORY, TIRUCHIRAPALLI.		SHEET NO 1
AMENDMENTS	SIGNATURE & DATE	APPROVED ON:	1/93		

MATL. AUTHY:- O&A (MAT), ICHAPUR LETTER NO. MQA-1/INCAST/7/5 DT. 14.10.93.