

TABLE 1
Technica 1

SHEET	Item	Назначение	Обозначение
1	MAIN VIEW	2-2	C ₁
	UPPER VIEW	Bud chery	A ₁ B ₁ F ₁ A ₁ U ₁
	B-B		3, M ₁ H ₁
	H-H		C U ₁ 10 A
	VIEW B-B		U ₁ V ₁ K ₁
2	LOWER VIEW		U ₂
	3-3		U ₂ U ₂ U ₂ T ₂
	K-K		K ₁ A ₁ M ₁ P ₁

TABLE 2
Technica 2

CYLINDER NUMBER	DIMENSION	DIMENSION
1	24	73
2	21	71
3	18	69
4	17	67
5	20	65
6	12	63

EST. MASS 27.6 kg TO BE STAMPED OR MARKED WHERE INDICATED THIS IS LETTERS!

ALL SHARP EDGES AND CORNERS TO BE REMOVED UNLESS OTHERWISE STATED MATCHED CORNERS TO HAVE R. OUT. SIDE R. RESE EQUIVALENT CHAMFERS ARE PERMISSIBLE.

DRN: [Signature] DATE: 1978-08-18 SCALE: 1:1

MATERIAL: [Blank] USED ON: C6 303-03-1

CONTROLLERATE OF QUALITY ASSURANCE/HEAVY VEHIC A V A D I

TITLE: CYLINDER JACKET R.M. ASSY.

D 5 CAT NUMBER: [Blank] DRAWING NUMBER: 577-2 C6 303-06-16 CB



DRAWING NUMBER
СБ 303-05-6 СБ

1. Маркировать, выбранным способом.
 2. Остальное - см. СБ 303-06-18 СБ.

1. TO BE MARKED BY PUNCHING.
 2. FOR OTHER REQUIREMENTS, SEE СБ 303-06-18 СБ.

DRIVE SIDE
 Сторона
 передачи
 A →

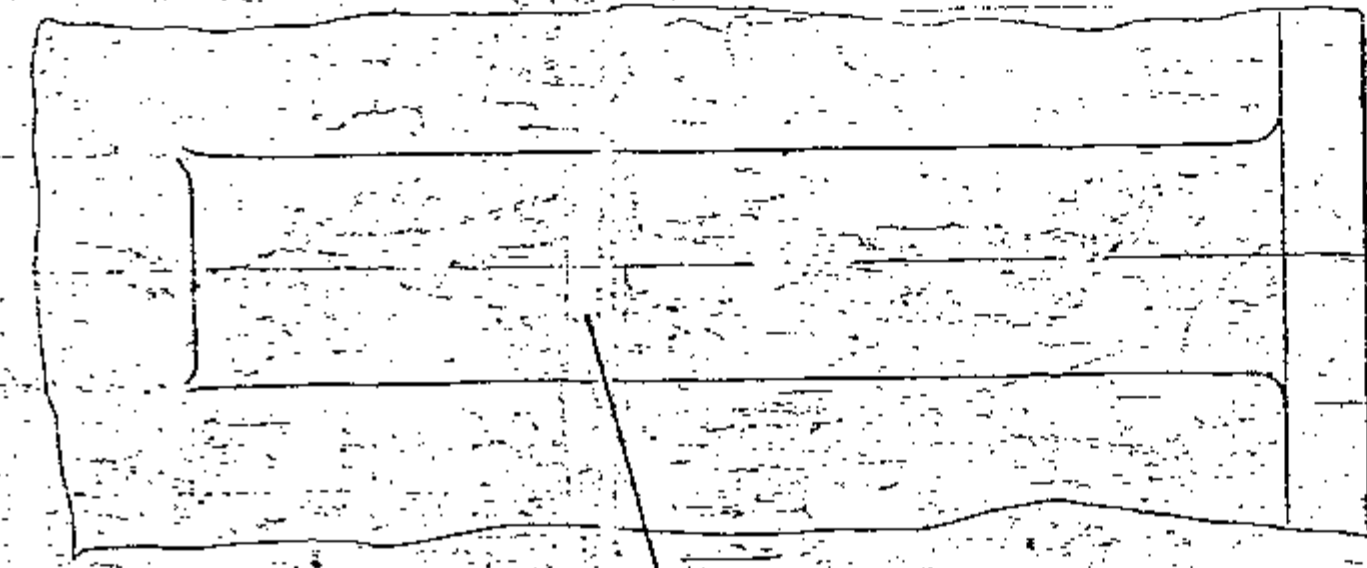
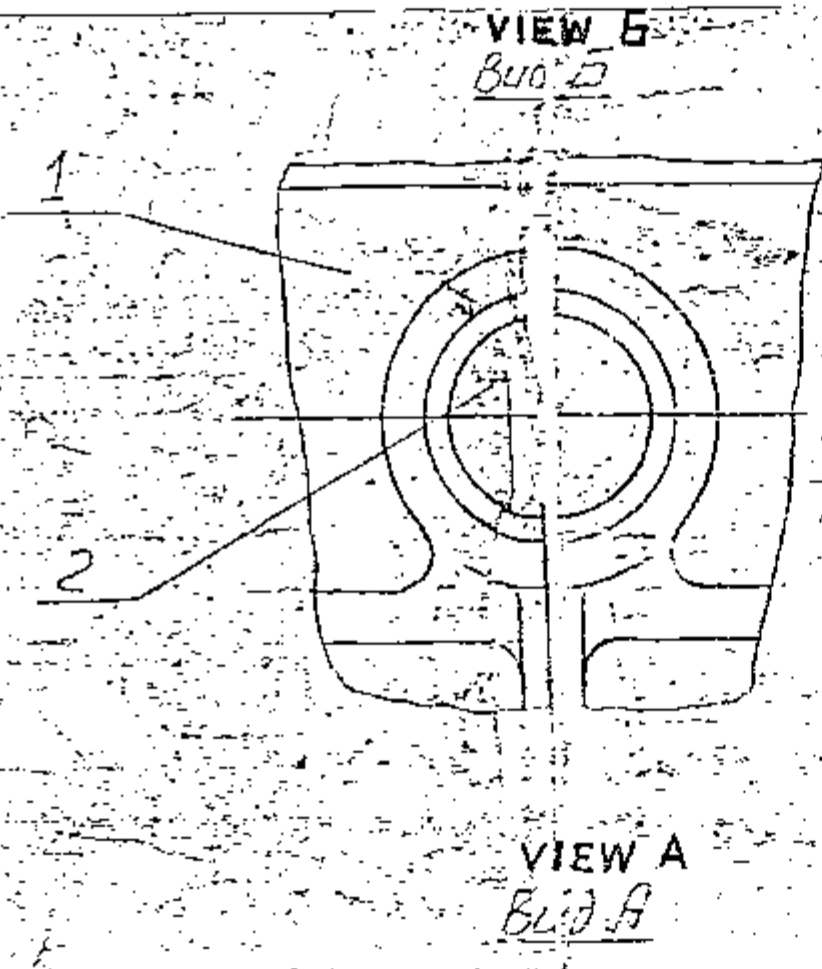
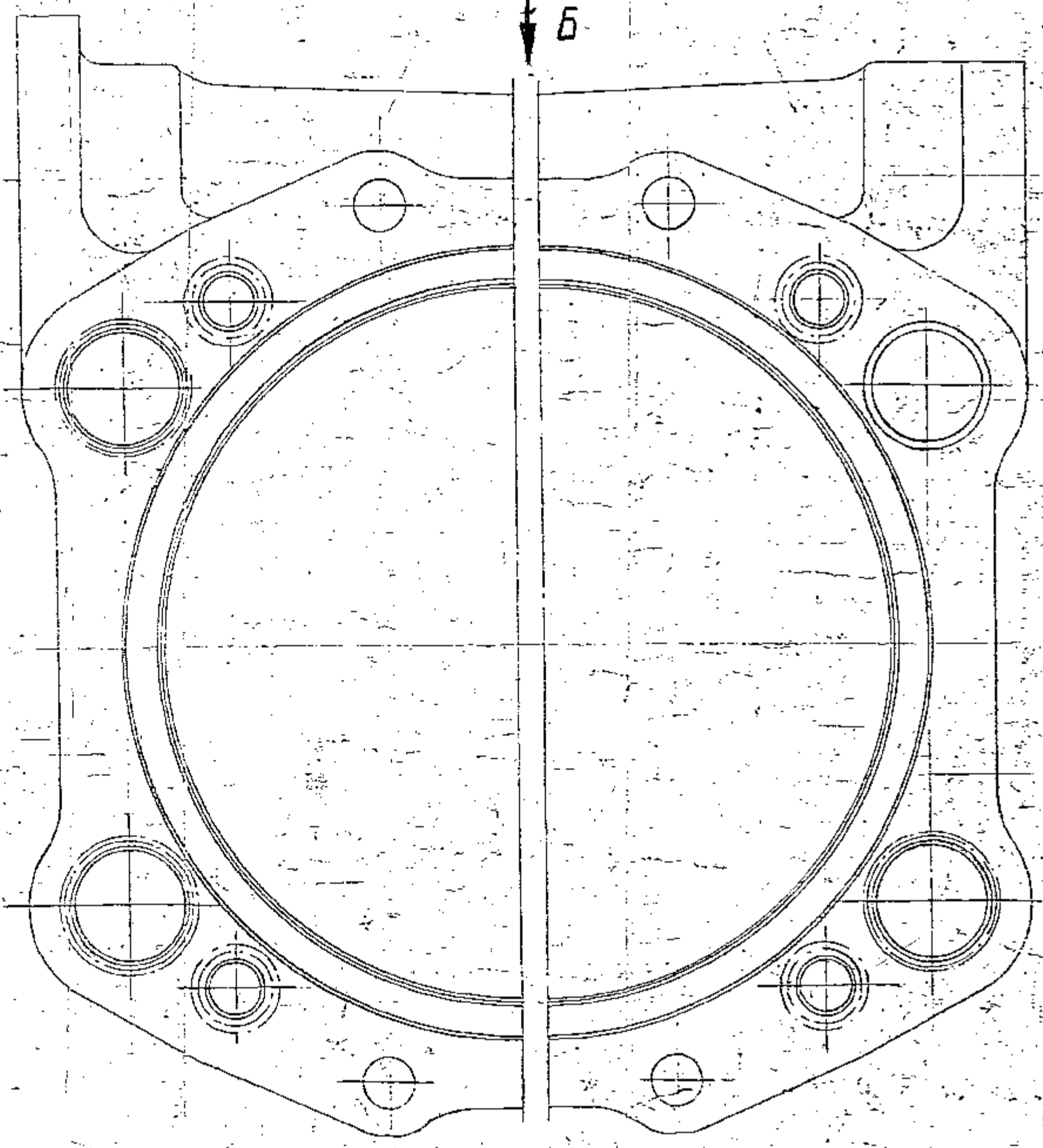

PILOT SAMPLE SHOULD BE APPROVED BY A H.S.P. BEFORE BULK PRODUCTION.

EST. WT.	TO BE STAMPED OR MARKED WHERE INDICATED THUS # (LETTERS)
—	()
ALL SHARP EDGES AND CORNERS TO BE REMOVED UNLESS OTHERWISE STATED MACHINED CORNERS TO HAVE R OUTSIDE R INSIDE EQUIVALENT CHAMFERS ARE PERMISSIBLE.	

DRN	CHD	TCD	APPE	DATE	SCALE	DIMENSIONS IN mm.	TOLERANCE ON DIMNS UNLESS OTHERWISE STATED IS 2102-69	ALL THREADS TO CONFORM TO
				30-09-88	1:1			
				MATERIAL :-		USED ON :-		
						СБ 303-02-16		
				CONTROLLERATE OF QUALITY ASSURANCE (HEAVY VEHICLES)		A V A D I		
				TITLE		CYLINDER JACKET L.H		
				D S CAT NUMBER		DRAWING NUMBER		
						СБ 303-05-6 СБ		
ISSUE	DATE	NATURE OF AMENDMENTS						



DRAWING NUMBER
Cb.303-02-23

SHEET No. 1 OF 1

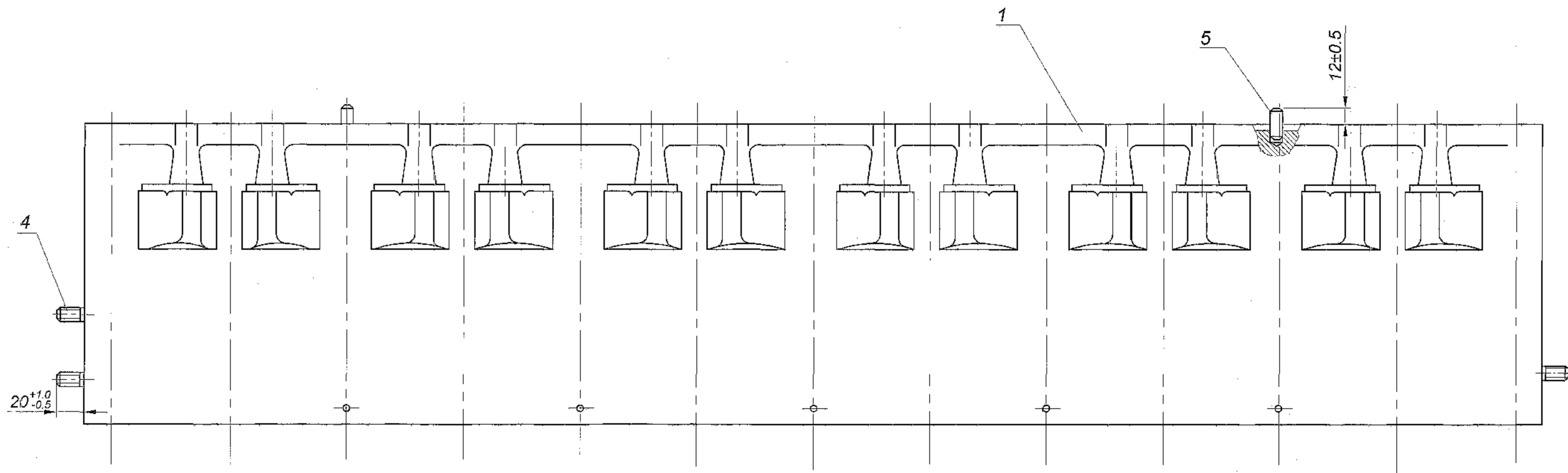

1. Pressure test is to be carried out with water under a pressure of 0.25MPa (2.5Kgf/cm²) 0.3MPa (3 Kgf/Cm²) at temperature of 60.....70°C for 3 minutes minimum. This is to be conducted before mounting stud and pins.

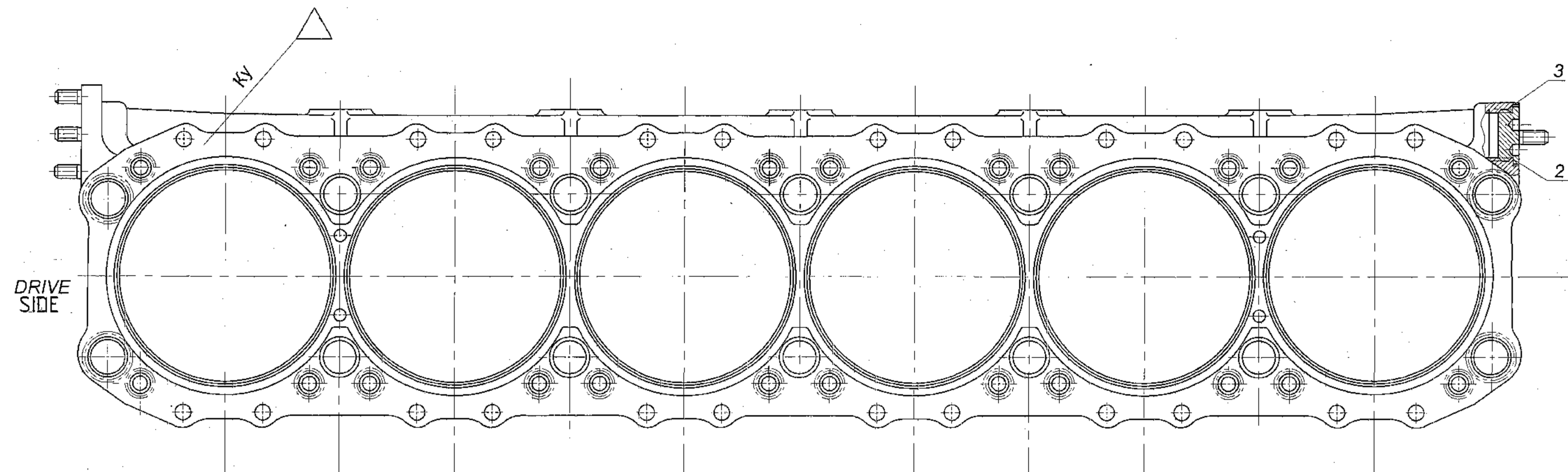

DRG. INDIANISED BASED ON RUSSIAN ORIGINAL ISSUE - 2

PILOT SAMPLE SHOULD BE APPROVED BY A H S P BEFORE BULK PRODUCTION.

EST. WT. 28.36 TO BE STAMPED OR MARKED WHERE INDICATED THUS # (LETTERS)

ALL SHARP EDGES AND CORNERS TO BE REMOVED UNLESS OTHERWISE STATED MACHINED CORNERS TO HAVE R OUT-SIDE R INSIDE EQUIVALENT CHAMFERS ARE PERMISSIBLE.

DRN	ALL	MATERIAL	USED ON
CHD	K. S. S. S.		Cb 303-01-23
APPD		CONTROLLERATE OF QUALITY ASSURANCE (HEAVY VEHICLES)	
DATE	01/2/87	AVADI	
SCALE	1:2		
DIMENSIONS IN mm			
TOLERANCE ON DIMS UNLESS OTHERWISE STATED IS: 2102 - 69			
ALL THREADS TO CONFORM TO			
ISSUE	DATE	NATURE OF AMENDMENTS	

TITLE: **CYLINDER JACKET LH ASSY**

D S CAT NUMBER
DRAWING NUMBER
Cb.303-02-23

F-3
31
166

SIZE A1

