

DRG No. 2101 02 05 12 001 00DA  
 IC SS S VV V C LSS  
 1 0 1 2 0 0 0 0 0 0 0 0 0 0 0 0 0 0 0 0

GENERAL TOL. : FINE / MEDIUM / COARSE  
 CLASS TO IS: 2102  
 DRG. CONVENTIONS CONFIRM TO INDIAN STANDARDS  
 DIMENSIONS ARE IN mm UNLESS OTHERWISE STATED.

SR. No.	NOMENCLATURE	DRAWING NUMBER	QTY.
1	COCKING HANDLE	2101 01 02 05 12 001 00DA	1
2	PIN COCKING HANDLE	2101 01 02 05 12 002 00DA	1
3	SPRING COCKING HANDLE	2101 01 02 05 12 003 00DA	1
4	STUD COCKING HANDLE	2101 01 02 05 12 004 00DB	1

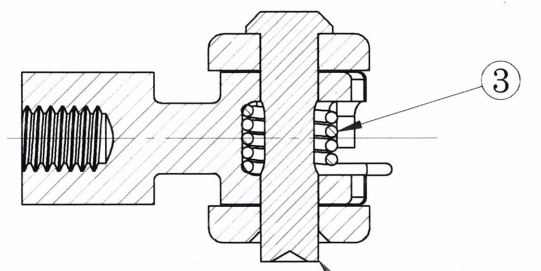
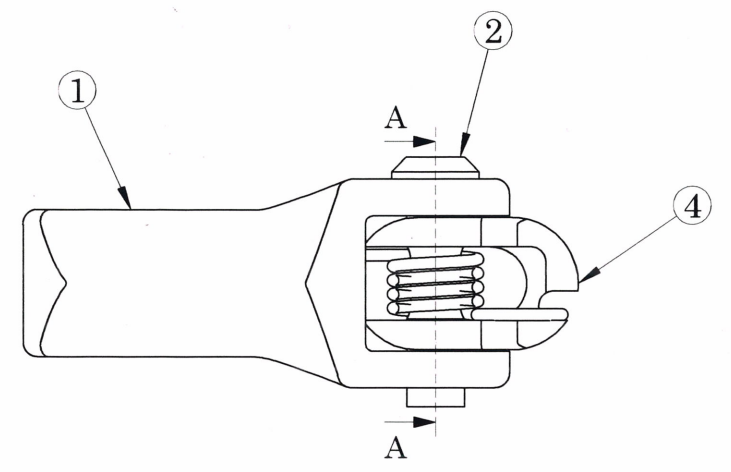

PIN COCKING HANDLE TO BE STABBED WITH SUITABLE TOOL

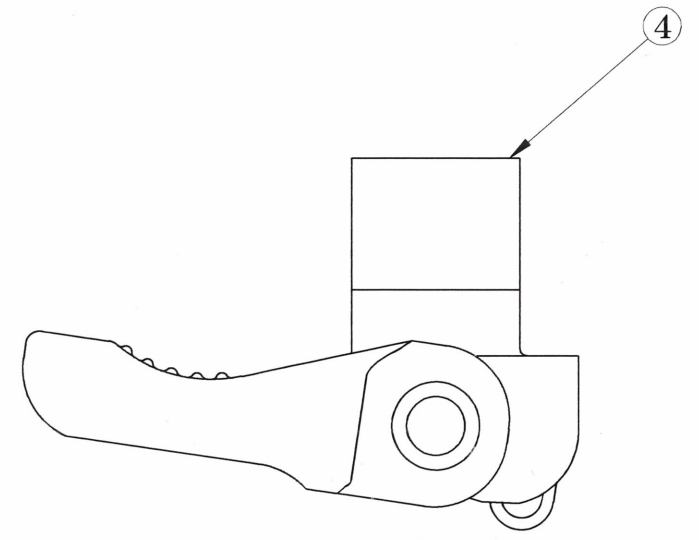

1.	17/11/2022	MP-01	DRAWING REVISED	-----	<i>Signature</i>	<i>Signature</i>
Sr. No.	DATE	AUTHORITY	BRIEF RECORD	ZONE	CD	GO
DRN: SOURABH	DATE: 24/08/2022	<i>Signature</i> CHECKED	MATERIAL:	-----		
APPD.	DATE: 24/08/2022	<i>Signature</i> FOR DIRECTOR	PROTECTIVE FINISH:	-----		
SEALED DATE:	SHEET SIZE: A3	EST. MASS	TITLE:	COCKING HANDLE ASSEMBLY		
	SCALE: 2:1	-----				
DESIGN AUTHORITY	ARDE	PUNE 411021				
DRG No.	2 1 0 1	0 1	0 2	0 5	1 2	0 0 0
	IC	SS	S	AA	A	C
9 mm	PART No.		DS CAT No.		AHSP	

NOTE:  
 ASSMEBLY TO BE CARRIED OUT AS PER ASSEMBLY PROCEDURE  
 DOC. No. ARDE/9mm MP/ASSY/2022/01





1	2	3	4
ISS	0	V	01
V	0	0	0
2	0	0	0
2	1	0	5
2	0	0	2
1	0	1	0
1	0	1	2

GENERAL TOL. : FINE / MEDIUM / COARSE CLASS TO IS: 2102 DRG. CONVENTIONS CONFIRM TO INDIAN STANDARDS DIMENSIONS ARE IN mm UNLESS OTHERWISE STATED.

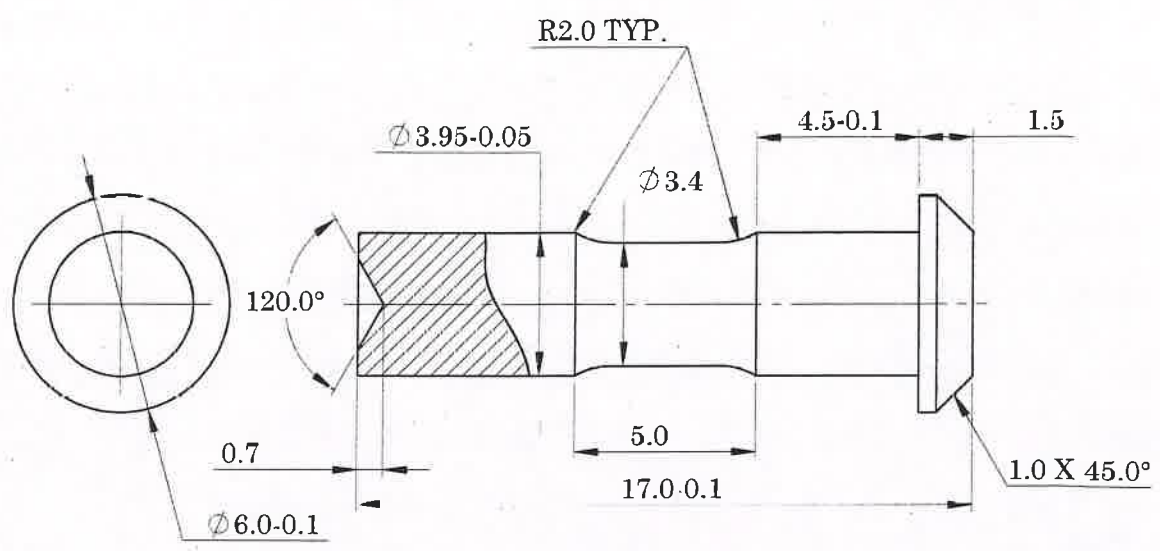

**COPY No.: 01**

- NOTE:**
- 1.REMOVE ALL SHARP EDGES AND BURRS.
  - 2.DIMENSIONS TO BE READ AFTER APPLYING PROTECTIVE FINISH.
  - 3.HARDNESS BEFORE COATING: 260 TO 310 HV.
  - 4.SURFACE FINISH  $\nabla$  ALL OVER UNLESS OTHERWISE SPECIFIED.

Sr. No.	DATE	AUTHORITY	BRIEF RECORD	ZONE	CD	GO
					SIGN	

DRN: AKASH  
SIGN: *[Signature]*  
DATE: 24/08/2022  
CHECKED

APPD. *[Signature]*  
DATE: 24/08/2022  
FOR DIRECTOR

SEALED  
DATE:

SHEET SIZE: A4  
SCALE: 5:1

DESIGN AUTHORITY  
ARDE  
PUNE 411021

EST. MASS  
1.54 gm

MATERIAL:  
STEEL TO IS:5517-1993,Gd.55C8 (EN-9)

PROTECTIVE FINISH:  
PHOSPHATED TO SPECN. IS:3618-1966, CLASS 'B'

TITLE:  
**PIN COCKING HANDLE**

DRG No.	2	1	0	1	0	1	0	2	0	5	1	2	0	0	2	0	0	D	A
	IC				SS		S		AA		A		C			SST			
9 mm	PART No.				DS CAT No.				AHSP										





