

54-83-006-1-2

CHEMICAL COMPOSITION (%)

	AJ9 GOST-2685-75
ALUMINIUM	BASE
MAGNESIUM	0.2 - 0.4
SILICON	6.0 - 8.0
MANGANESE	0.50 Max.
COPPER	0.20 Max.
ZINC	0.30 Max.
TIN	0.01 Max.
LEAD	0.05 Max.
BERYLLIUM	0.10 Max.
ZIRCONIUM	0.15 Max.
IRON	1.50 Max.

MECHANICAL PROPERTIES

PARTIAL RESISTANCE 17 Kg/mm ² Min ⊕
SPECIFIC ELONGATION % 1 Min ⊕
HARDNESS, HB. 50 Min ⊕

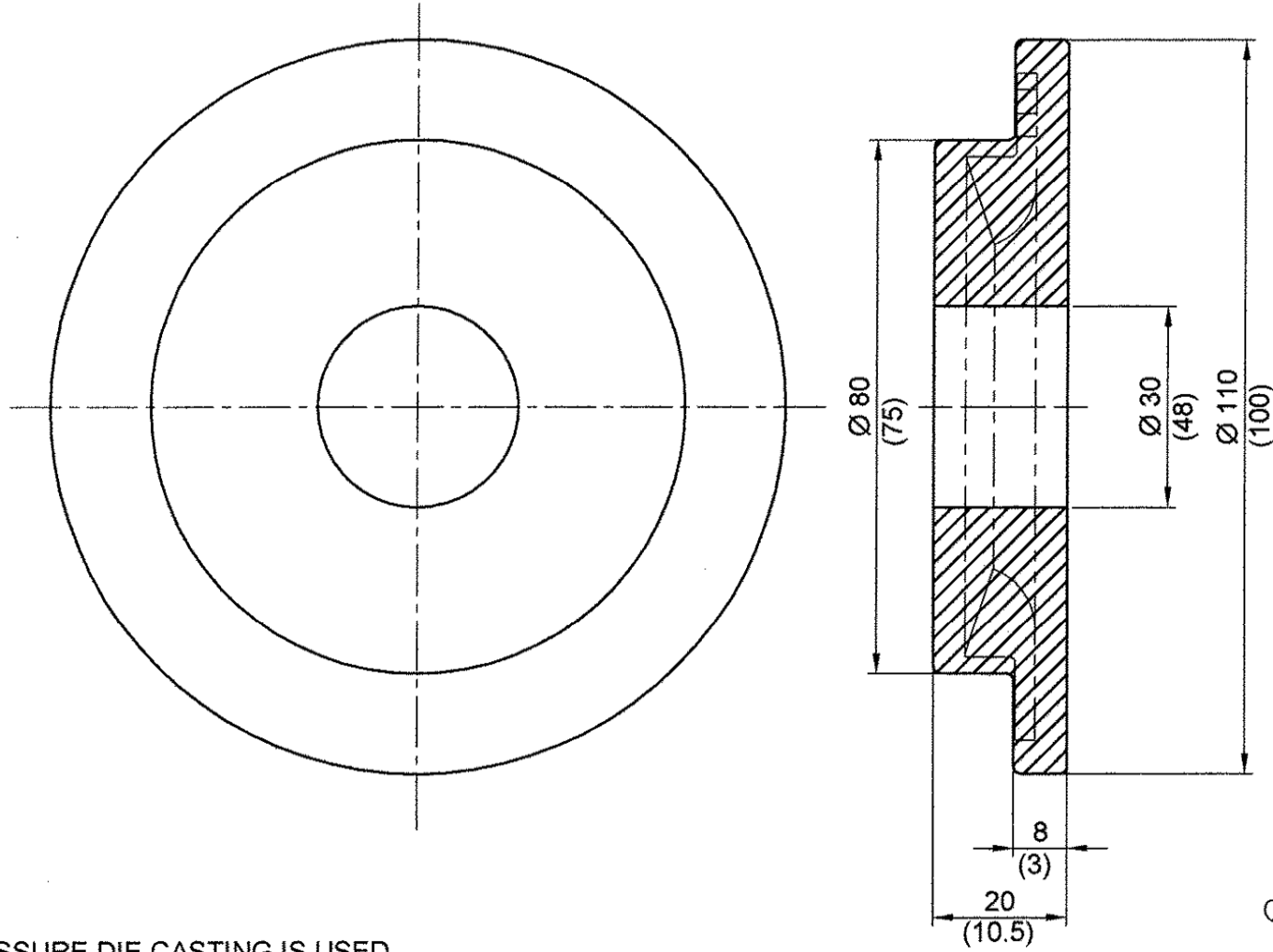

VETTED
3 NOV 2007
JWM/STD-CELL

NOTE: RADIOGRAPHY TESTS IS MEANT FOR TRADE SUPPLIES ONLY

- PRESSURE DIE CASTING IS USED.
- PATTERN DRAFTS SHOULD NOT EXCEED 2°.
- UNSPECIFIED CASTING RADII SHOULD NOT EXCEED 5 mm.
- UNSPECIFIED THICKNESS OF RIBS IS 8 ± 2mm AND THAT OF WALL 11 ± 1mm.
- UNSPECIFIED LIMIT DEVIATIONS OF DIMENSIONS ARE ± 1.5 mm
UP TO 100 mm. ± 2.0mm . FROM 100 mm. TO 300 mm. ± 3.0mm. MORE THAN 300 mm.
- MARK AJ9 AND TID STAMP.
- OTHER REQUIREMENTS ARE AS PER TT UJ 370.

NOTE:-
CASTING SHOULD BE TESTED FOR RADIOGRAPHIC TEST AS PER ASTM E- 155 : 2000, LEVEL - I

इन आरेखणों तथा इसके साथ की सम्पूर्ण सामग्री का स्वत्वाधिकार भारत सरकार रक्षा मंत्रालय की भारतीय आयुध निर्माणियों के पास है। भारतीय आयुध निर्माणियों के महानिदेशक की लिखित अनुमति के बिना इनकी नकल या किसी भी रूप में इनके उद्धरण या इनमें समाहित सूचना किसी अनधिकृत व्यक्ति को उपलब्ध नहीं कराई जानी चाहिए।
THE COPYRIGHT OF THESE DRAWINGS AND ALL ATTACHMENTS THERE TO BELONGS TO THE INDIAN ORDNANCE FACTORIES, MINISTRY OF DEFENCE, GOVT. OF INDIA THEY SHOULD NOT BE COPIED, REPRODUCED IN ANY WAY OR THE INFORMATION CONTAINED THEREIN MADE AVAILABLE TO UNAUTHORISED PERSONS WITHOUT THE WRITTEN PERMISSION OF THE DIRECTOR OF ORDNANCE FACTORIES.

मूलमाप व अन्वायोजन NOMINAL SIZE & FIT	विवलन DEVIATION
--	--------------------

संख्या NO.OFF	विवरण DESCRIPTION	पुर्जा क्र. PART NO.	पदार्थ MATERIAL	मानक STANDARD	परिमाणु DIMENSIONS	अध्यक्षित REMARKS
	सामान्य सहिष्णुता GENERAL TOLERANCE			AJ9 GOST-2685-75		WT-0.335 Kg
	रेखिक परिमाण LINEAR DIMENSION					
	कोणीय परिमाण ANGULAR DIMENSION					
	मापोंक 'म्यू एम' में VALUE IN 'um'					
	संख्या NO.OFF	संबंधित पुर्जाका आरेखण क्र. DRG. NO. OF ASSOCIATED PART	सूचक INDEX	संशोधन ALTERATION	2007	दिनांक DATE
CASTING FOR COVER				मापमान SCALE	आरेखित DRAWN	3.11.07
CODE- 38				NTS	जाँचा CHECKED	Y.D.K.
					अनुमोदित APPROVED	A.K.N.
					द्वारा बदला REPLACED BY	
					हेतु बदला REPLACED FOR	
				कार्यालय OFFICE	आरेखण क्र. DRAWING NO.	
				MACHINE TOOL PROTOTYPE FACTORY, AMBERNATH	D.O.	54-83-006-1-2