

1	2	3	4	5	6	7	8
LSS	O	V	VA	S	SS	CI	
V	0	2	0	2	1	1	2
0	0	0	0	0	0	0	1
0	0	0	0	0	0	0	0

DRG No. 2101 01 02 02 07 000 00DA

GENERAL TOL : FINE / MEDIUM / COARSE
CLASS TO IS: 2102

DRG. CONVENTIONS CONFIRM TO INDIAN STANDARDS
DIMENSIONS ARE IN mm UNLESS OTHERWISE STATED.

CONTROLLED COPY No. 01

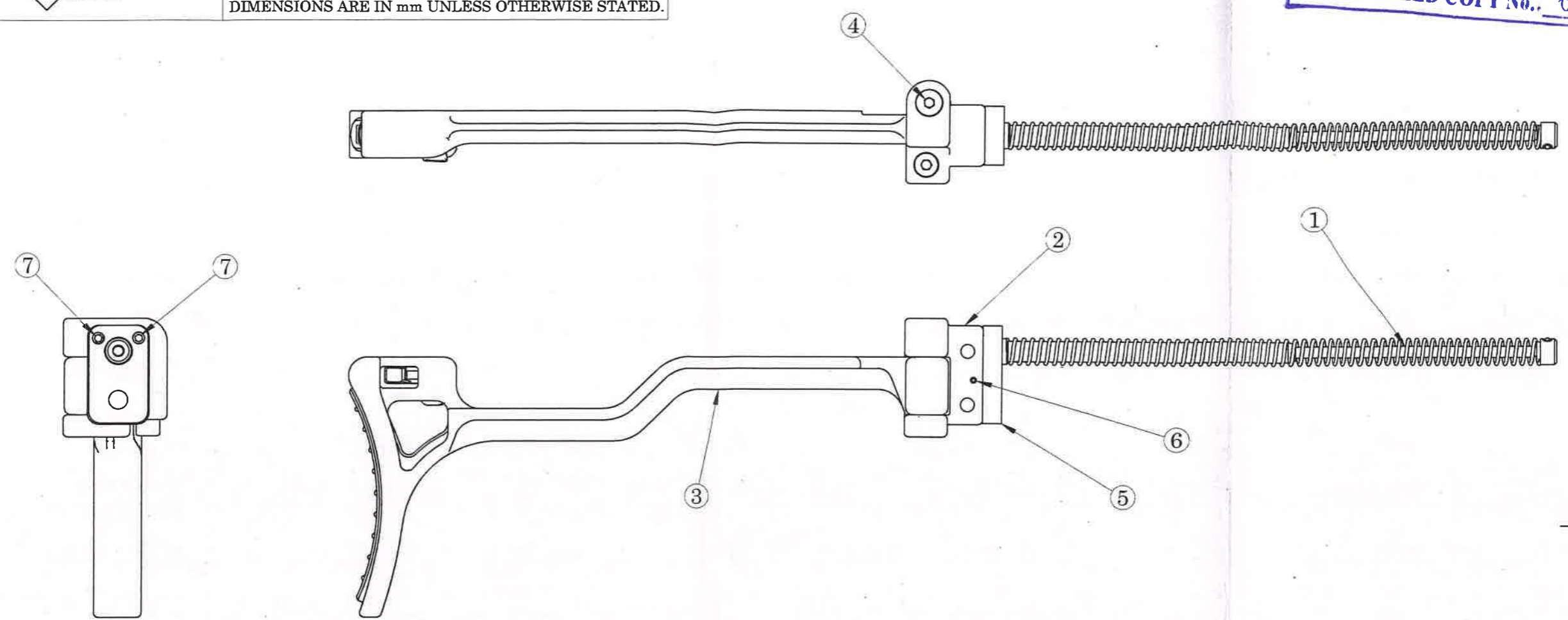

ITEM NO.	PART NUMBER	DESCRIPTION	QTY.
1	SPRING RECOIL ASSEMBLY	2101 01 02 02 07 000 00DA	1
2	PLATE REAR ASSEMBLY	2101 01 02 02 08 000 00DA	1
3	BUTT ASSEMBLY	2101 01 02 02 09 000 00DA	1
4	SCREW BUTT ASSEMBLY	2101 01 02 00 02 001 00DA	1
5	BUFFER PLATE	2101 01 02 00 02 002 00DA	1
6	PIN LOCKING BUFFER PLATE	2101 01 02 00 02 003 00DA	1
7	SCREW BUFFER PLATE	2101 01 02 00 02 004 00DA	2

NOTE:
ASSMEBLY TO BE CARRIED OUT AS PER ASSEMBLY PROCEDURE
DOC. No. ARDE/9mm MP/ASSY/2022/01

Sr. No.	DATE	AUTHORITY	BRIEF RECORD	ZONE	CD	GO
DRN: AKASH	DATE: 24/08/2022	<i>Paulam</i> CHECKED	MATERIAL:			
APPD.	DATE: 24/08/2022	<i>[Signature]</i> FOR DIRECTOR	PROTECTIVE FINISH:			
SEALED	DATE:					
SHEET SIZE: A3	SCALE: 1:2	EST. MASS	TITLE:			
DESIGN AUTHORITY	ARDE	PUNE 411021	PLATE REAR & BUTT ASSEMBLY			
DRG No.	2	1	0	1	0	2
	IC	SS	S	AA	A	C
9mm	PART No.	DS CAT No.	AHSP			

DRG No. 2101 01 02 02 07 000 00DA

IC SS S AA A C SST