

DRAWING NUMBER
3305-119

Rz80 ✓ (✓)

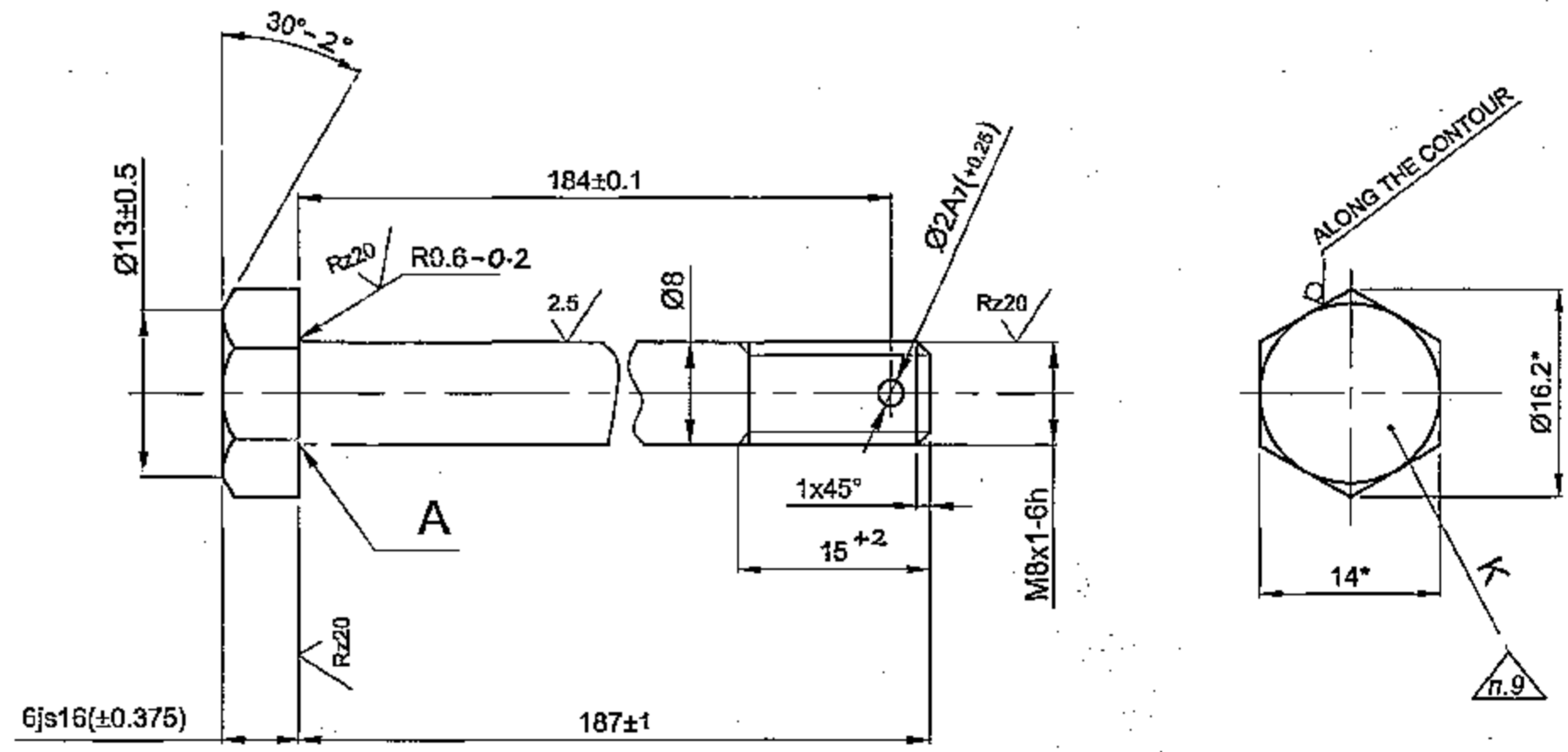

1. Inspection group III as per TT-11.
2. HRC 28...35.
3. The thread surface should be clean with out scores, burrs, break of turns, dents, corrosion marks.
4. Threads are made by rolling after the heat treatment with the diameters of unthreaded portion within the limits of mean diameter of the threads. Peeling of metal is not allowed.
5. Tool mark of width upto 2 mm with projection or sinkage of not more than 0.15 mm and roughness of surface $Rz20$ is allowed on the place 'A'.
6. Manufacturing of bolts from calibrated rods as per GOST 7417-75 by the method of electrical heating and upsetting of the bolt head without machining on rod with increased thickness of the stem under the head upto $\varnothing 6$ for length 5-10 mm.
7. The remaining T.R are as per standard 82052-00.
8. Chemically oxidized, oiled coating.
9. Stamp by punching.
10. *Dimension are given for reference.

ALTERNATIVE

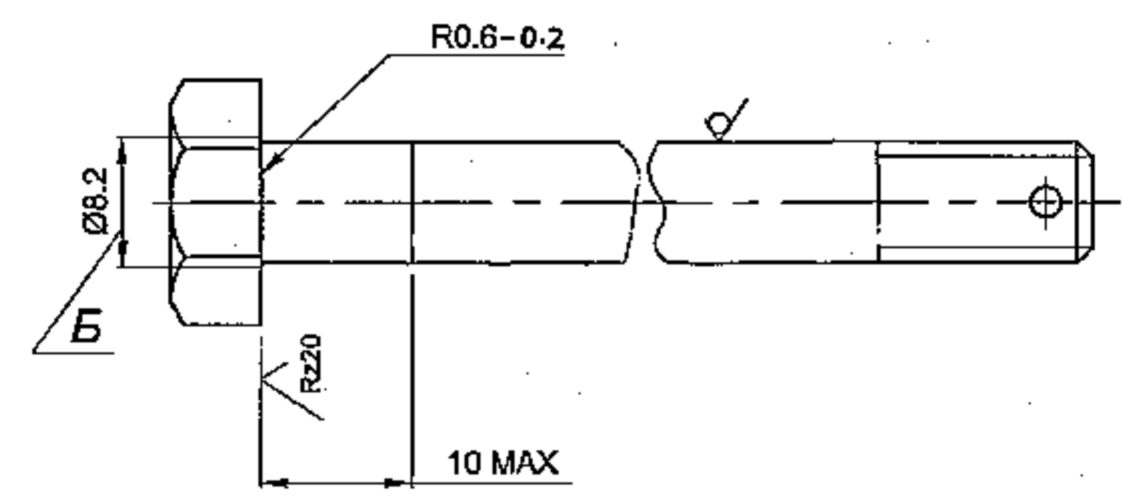

DRAWING INDIANISED BASED ON RUSSIAN ORIGINAL ISSUE - 11
DRG. REPLACES 3305-119, ISSUE-NIL VIDE NOTIFICATION NO: 92-227
COMMON TO V-9252

F-153
66
74
SIZE A2

PILOT SAMPLE SHOULD BE APPROVED BY A H S P BEFORE BULK PRODUCTION.

| | |
|--|---|
| EST. WT. 0.08 Kg | TO BE STAMPED OR MARKED WHERE INDICATED THUS # (LETTERS) |
| ALL SHARP EDGES AND CORNERS TO BE REMOVED UNLESS OTHERWISE STATED MACHINED CORNERS TO HAVE R OUTSIDE R INSIDE EQUIVALENT CHAMFERS ARE PERMISSIBLE. | |

ⓂA EQUIVALENT MATERIAL
STEEL 709 M40 (EN 19) EA TO BS: 970
40 Cr Mo 3 TO IS: 1570

| | | | | | | | | |
|-------|---------|---|----------|-------|------------------|---|---|-----------------------------|
| DRN | CHD | APPD | DATE | SCALE | DIMENSIONS IN mm | TOLERANCE ON DIMNS UNLESS OTHERWISE STATED IS : 2102 . 69 | MATERIAL :- HEXAGON 14.5 GOST8560-78 38XA-B GOST1051-73 | USED ON :- Sb 3305-03-15 |
| | | | 23.11.07 | 2:1 | | | CONTROLLERATE OF QUALITY ASSURANCE (HEAVY VEHICLES) AVADI | |
| | | | | | | | TITLE :- BOLT | |
| | | | | | | | D S CAT NUMBER | DRAWING NUMBER 3305-119 |
| 11A | 15-7-10 | 4.16 ALT.COMM.Mtg. MINUTES POINT No 10 DT 26.10.09 | | | | ALL THREADS TO CONFORM TO | | |
| ISSUE | DATE | NATURE OF AMENDMENTS | | | | | | |