

NOTE
 ACCEPTANCE STANDARDS FOR MACRO ETCH TEST & MICROSCOPIC DETERMINATION OF NON METALLIC INCLUSIONS FOR STEEL
 1. MACRO ETCH TEST AS PER ASTM E- 381 WITH ACCEPTANCE STANDARD AS C2, R2, S2
 2. NMIR TEST AS PER IS : 4163 - 82
STRESSED COMPONENT

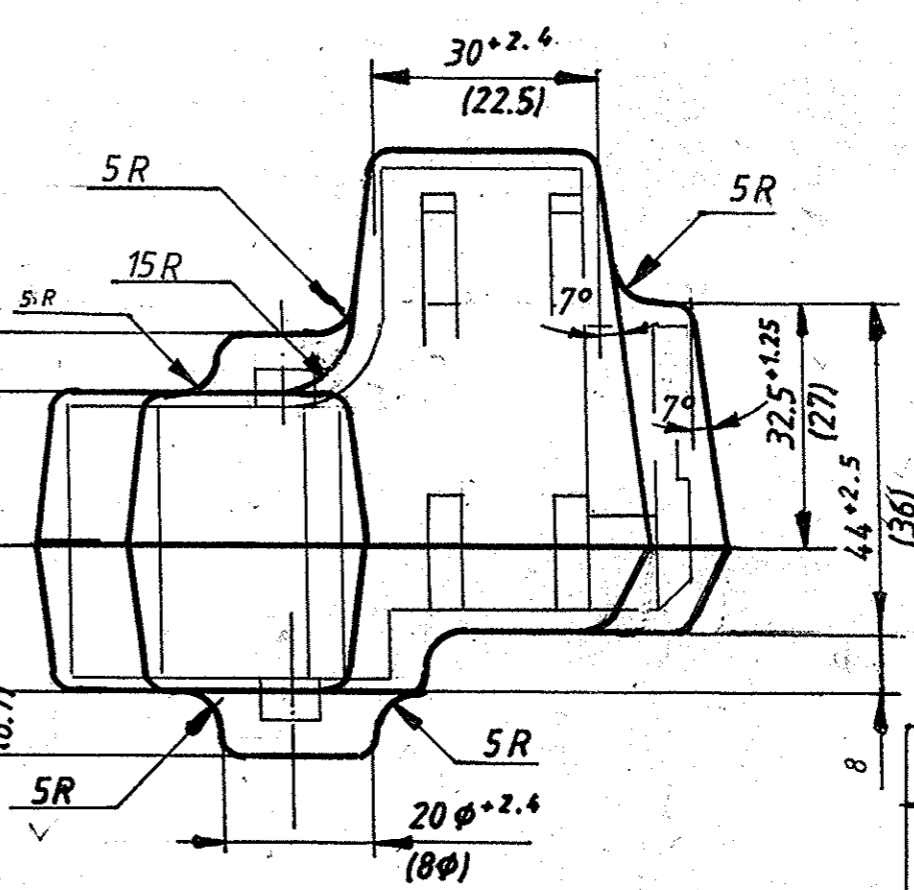

CHEMICAL COMPOSITION AND MECHANICAL PROPERTIES OF MATERIAL 30XH2MØA-a

C	0.27 - 0.34
Si	0.17 - 0.37
Mn	0.30 - 0.60
Cr	0.60 - 0.90
Mo	0.20 - 0.30
Ni	2.0 - 2.4
V	0.10 - 0.18
P	0.025 MAX.
S	0.025 MAX.
Cu	0.20 MAX.
HARDNESS	269 HB
TENSILE STRENGTH	90 Kg/mm ²
ELONGATION	10%
REDUCTION IN AREA	40%
IMPACT STRENGTH	9Kg M/cm ²
YIELD POINT	80Kg/mm ²

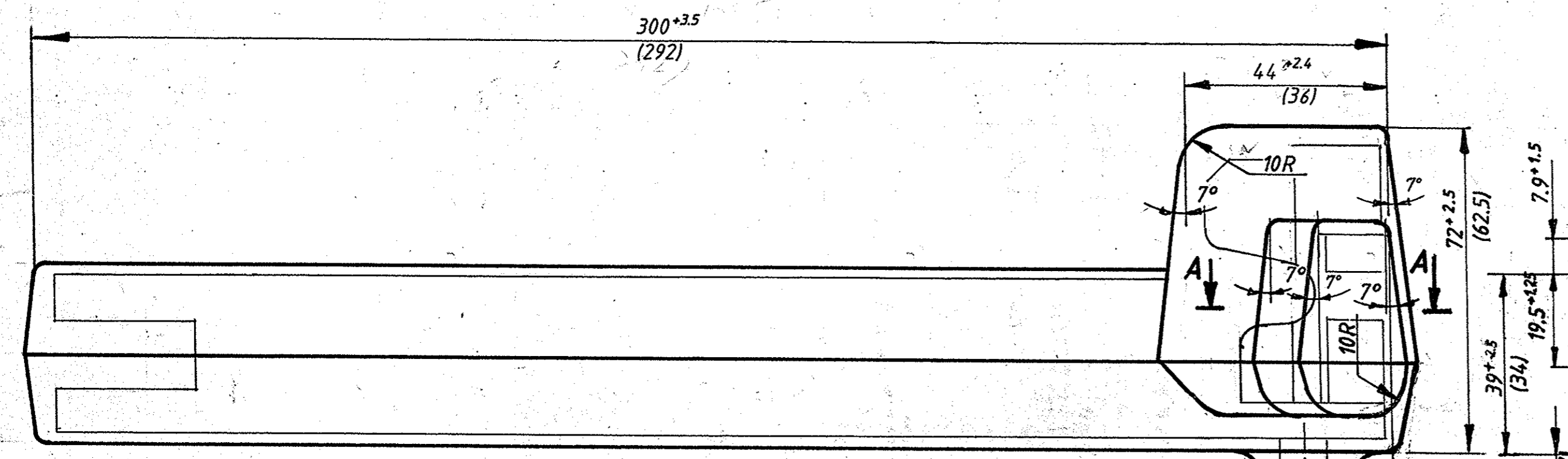
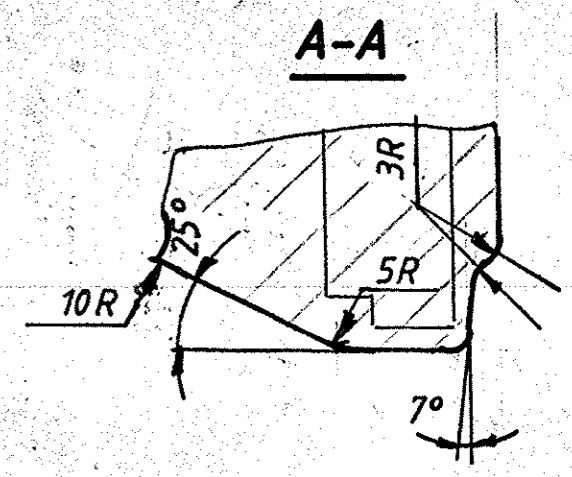
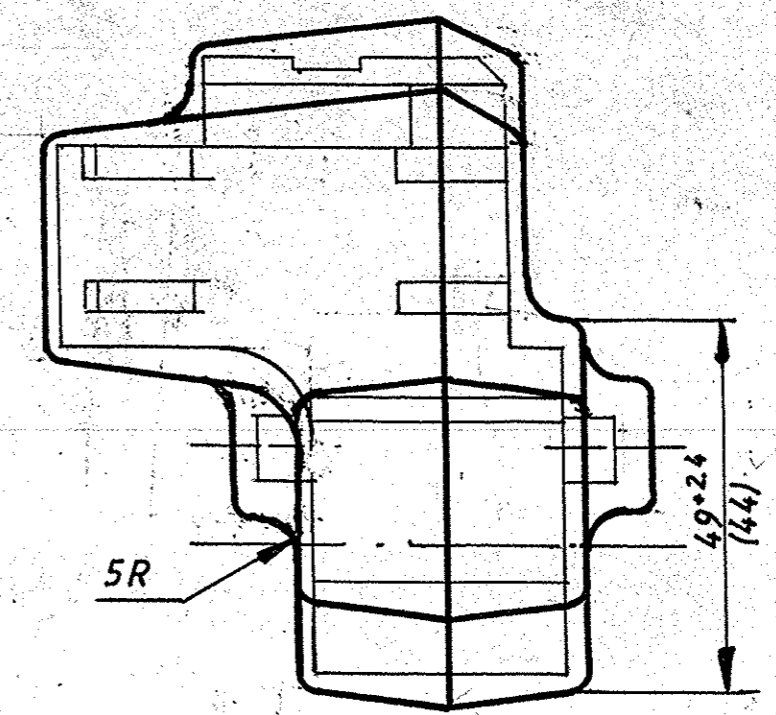
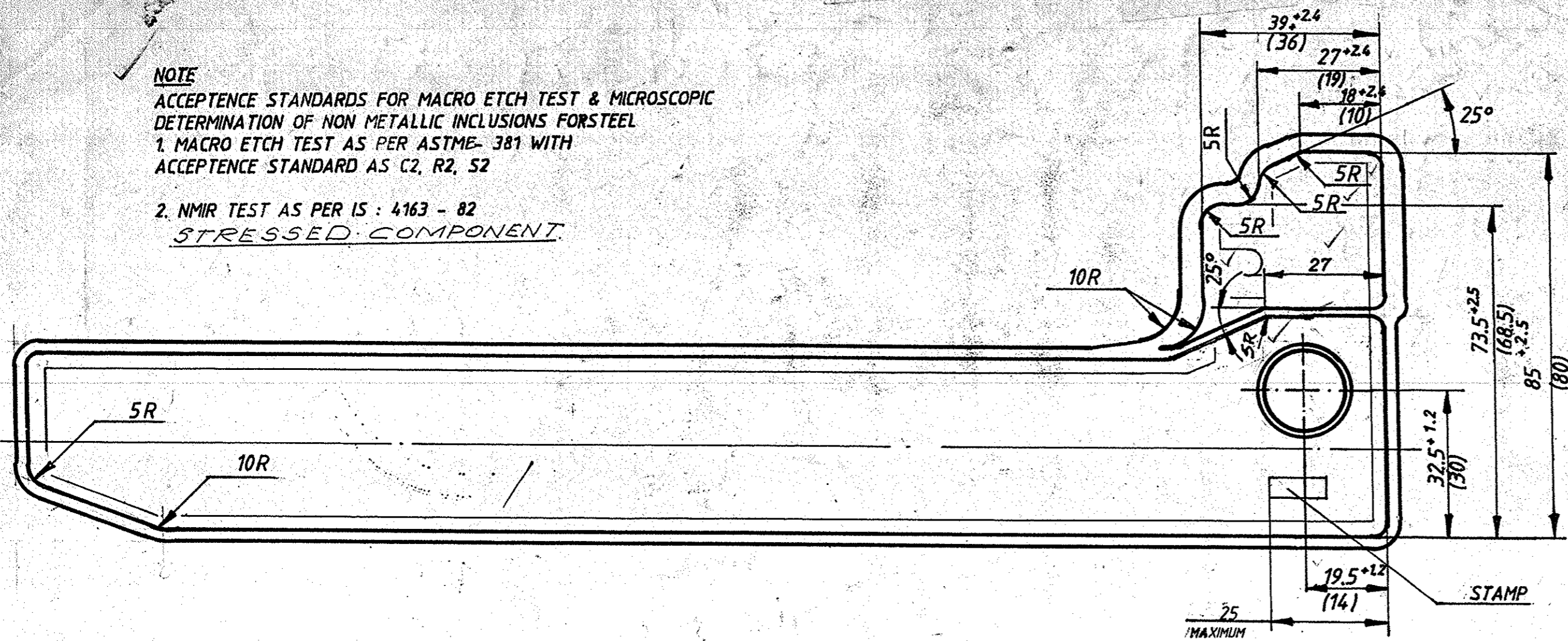
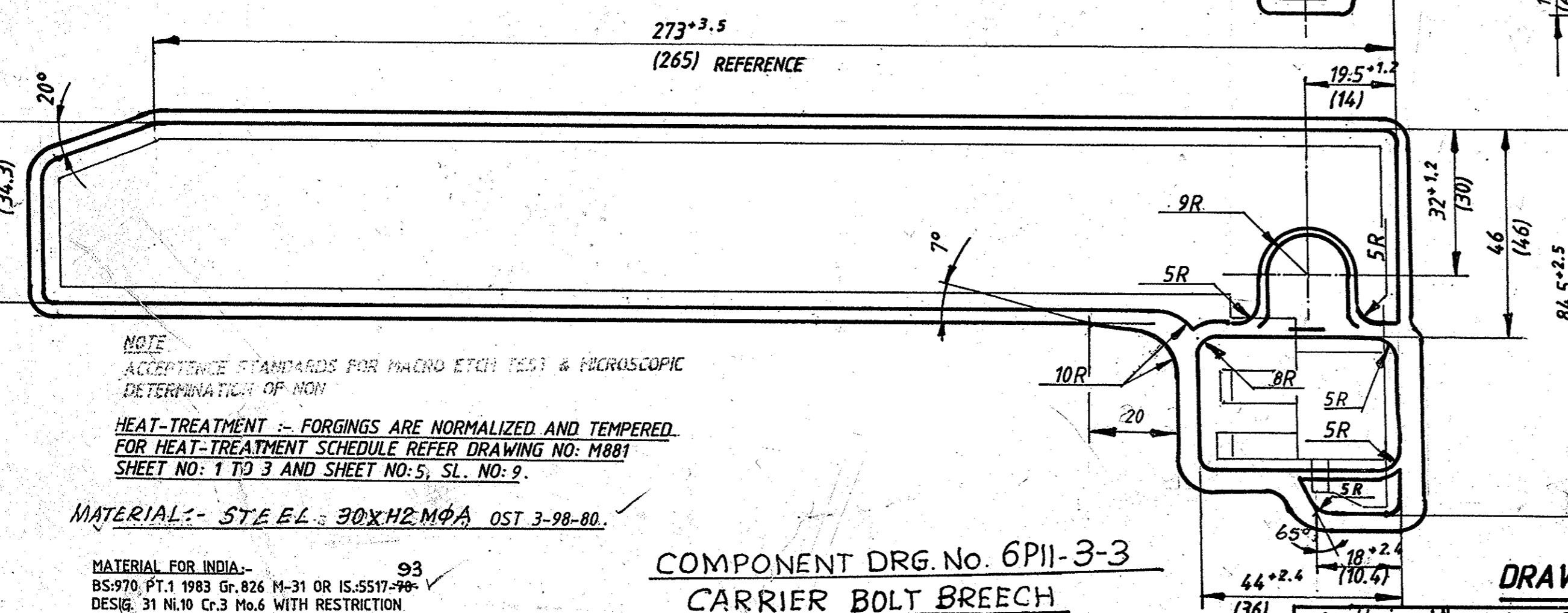

- NOTE:-**
- DIMENSIONS ARE IN mm.
 - FIRST ANGLE PROJECTION.
 - SCALE:- 1:1
 - FORGINGS OF GROUP III AS PER GOST 8479-70, HB 269 MAX.
 - DRAFT ANGLE:- 7°
 - UNSPECIFIED RADII 2.5:R
 - PERMISSIBLE FLASH REMAINERS 1.2 mm.
 - PERMISSIBLE DIE SHIFTING 0.9 mm.
 - PERMISSIBLE WARPING 1.2 mm.
 - DIMENSIONS GIVEN IN BRACKETS PERTAIN TO THE FINISHED PART.
 - STAMP PART NO.; MELT NO.; AND Q.C.D. STAMP.
 - 100% OF A BATCH SHOULD BE CHECKED FOR HARDNESS.
 - WEIGHT OF THE FORGING 4.880 Kgs.

VETTED FOR MATERIAL ONLY

Principal Engineering Officer,
 Quality Assurance Officer,
 For Senior Quality Assurance Officer,
 Senior Quality Assurance Officer,
 Tiruchirapalli-620 016.

NOTE
 ACCEPTANCE STANDARDS FOR MACRO ETCH TEST & MICROSCOPIC DETERMINATION OF NON
 HEAT-TREATMENT :- FORGINGS ARE NORMALIZED AND TEMPERED.
 FOR HEAT-TREATMENT SCHEDULE REFER DRAWING NO: M881
 SHEET NO: 1 TO 3 AND SHEET NO: 5, SL. NO: 9.

MATERIAL:- STEEL - 30XH2MØA OST 3-98-80.

MATERIAL FOR INDIA:- 93
 BS:970, PT.1 1983 Gr.826 M-31 OR IS:5517-79
 DESIG. 31 Ni.10 Cr.3 Mo.6 WITH RESTRICTION
 OF 'S' & 'P' CONTENT UP TO 0.025% MAX. FOR EACH.

**COMPONENT DRG.No. 6PII-3-3
 CARRIER BOLT BREECH**

DS CAT NO. 1005007309

DRAWING PROVISIONAL

REDRAWN	CHECKED	I/C. D&DO.	APPROVED	DIV.OFFICER

C	MATL. FOR INDIA ADDED DELETED 20741-SA DE 23-4-90, WIDE L.L. DE 14-5-90	
B	BI-LATERAL TOLERANCE DELETED & UNI-LATERAL TOLERANCE ADOPTED DRAWING NO. TNEED 562 DELETED AND RE-NUMBERED AS 62 C 3003 200 B 2. DRAWING UPDATED.	
AMEND- MENTS	DESCRIPTION / DETAILS	SIG. & DATE
	ORDNANCE FACTORY DRG NO: TIRUCHIRAPALLI-16	62 C 3003 200 B 2