

DRAWING No.
188.31.183/C

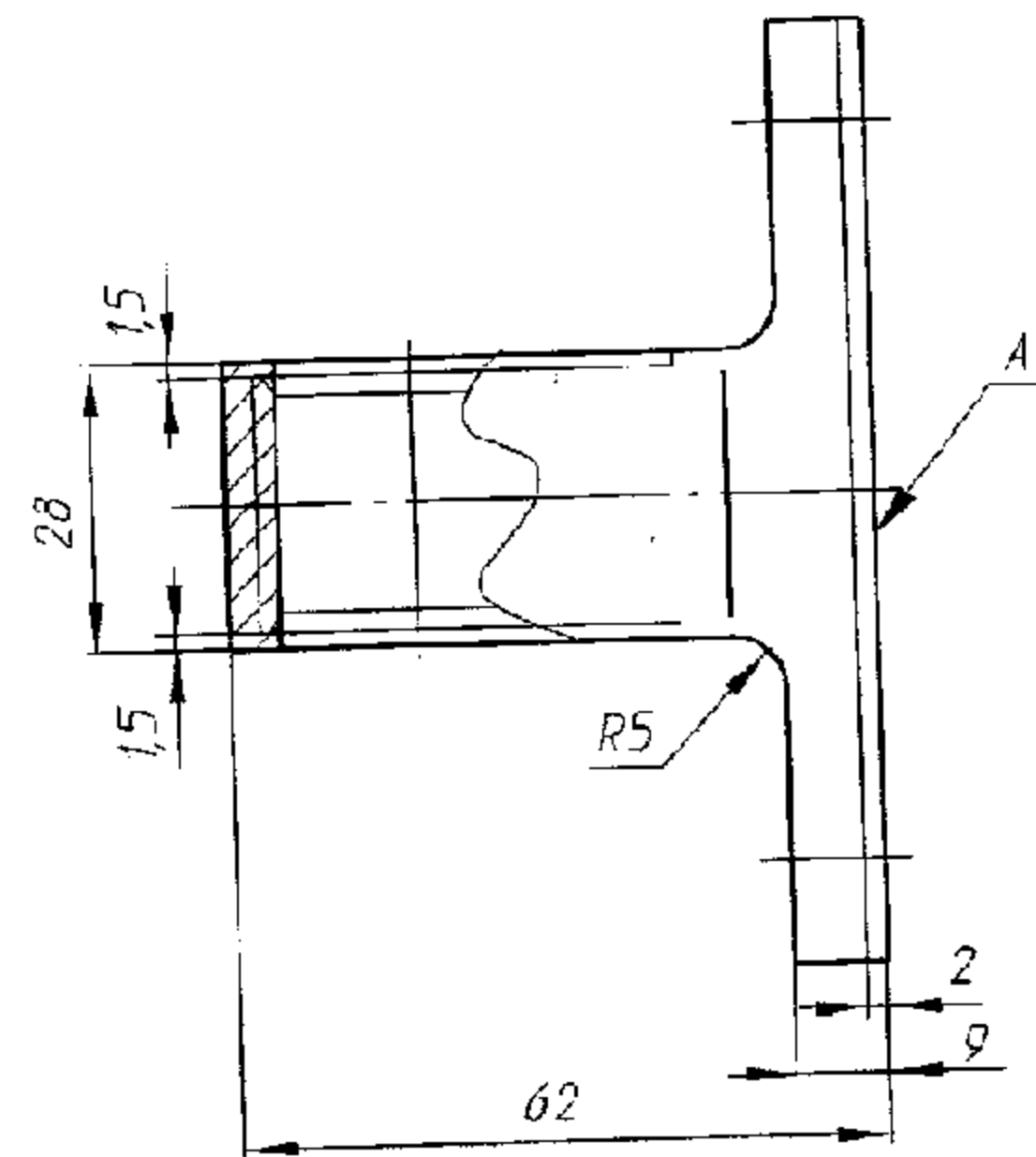
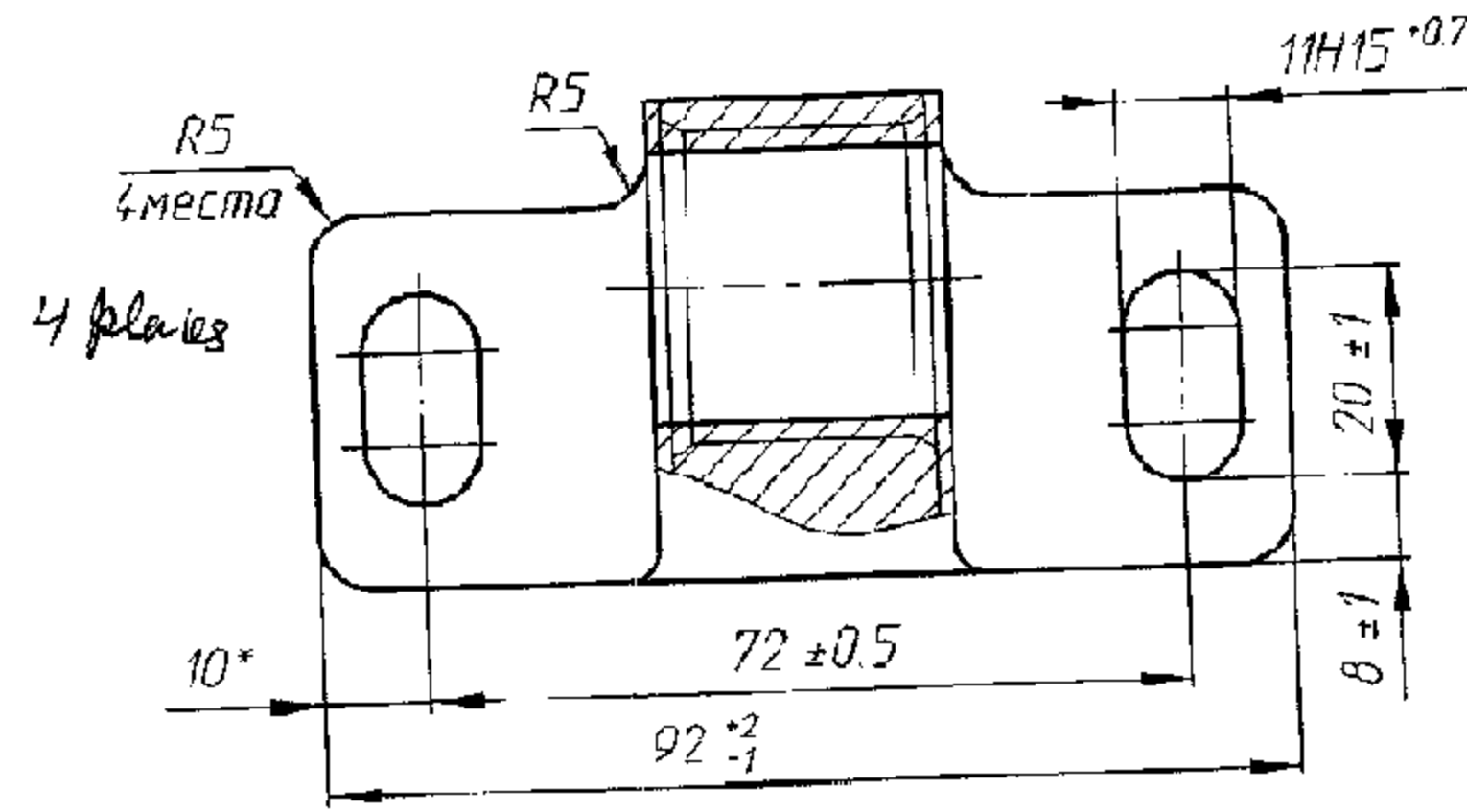
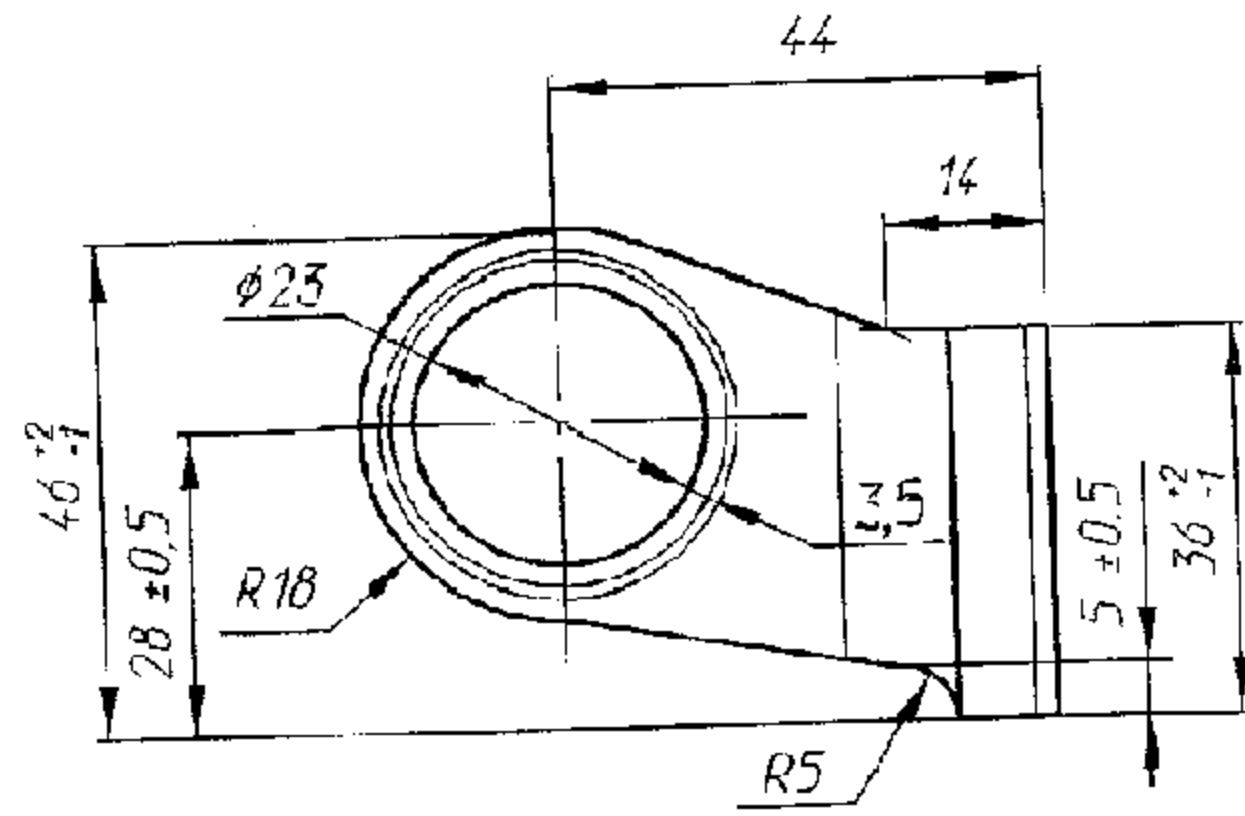

1. casting of 1st group GOST 977-88.
2. casting material - steel 25A GOST 977-88.
3. Alternate material - 20A, 30A, 20ФA GOST 977-88.
4. Accuracy of casting 9-0-0-9 GOST 26645-85.
5. Requirements for casting as per 172 TU 10.
6. un. specified radii - 2mm.
7. * Dimension for reference.
8. Scale 1:1.
9. on surface A, remnant of runner is allowed upto 5mm height.

MODIFICATIONS & ADDITIONS

ISSUE	MODIFICATIONS & N OF A	SIGN

1. отливка 1-й группы ГОСТ 977-88
2. Материал отливки сталь 25А ГОСТ 977-88
3. Материал-заменитель 20А, 30А, 20ФА ГОСТ 977-88
4. Точность отливки 9-0-0-9 ГОСТ 26645-85
5. Требования к отливке по 172 ТУ 10
6. Неуказанные радиусы 2 мм
7. *Размер для справок
8. Масштаб 1:1
9. На поверхности А допускается остаток от питателя высотой до 5 мм

PILOT SAMPLE SHOULD BE APPROVED BEFORE BULK PRODUCTION.

MATERIAL	EST. CASTING WT.	
25A GOST 977-88	0.6 kg	
ALTERNATE MATL.		SCALE
DRAWN	CHECKED	APPROVED

USER APPROVAL	DRAWING No. 188.31.183/C
	NOMENCLATURE BRACKET
	HEAVY VEHICLE FACTORY, AVADI, CHENNAI.