

SIZE A4

DATE 18.03.88

APFD Sd/=

CHD Sd/=

DRN Sd/=

ISSUE DATE

ALL THREADS TO CONFORM TO

TOLERANCE ON DIMENSIONS UNLESS OTHERWISE STATED IS: 2102-69

DIMENSIONS IN mm

SCALE:- 1 : 1

NATURE OF AMENDMENTS

D S CAT NUMBER

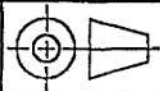

TITLE:-

CLAMP

DRAWING NUMBER 155.29.3039

CONTROL RATE OF QUALITY ASSURANCE (HEAVY VEHICLES) AVADI

5.0 GOST 19903-74
15 GOST 1577-70

MATERIAL:- SHEET
USED ON:- 172.04.148Cb-1Cb

ALL SHARP EDGES AND CORNERS TO BE REMOVED UNLESS OTHERWISE STATED MACHINED CORNERS TO HAVE R OUT-SIDE R INSIDE EQUIVALENT CHAMFERS ARE PERMISSIBLE.

EST. WT. (kg) 0.035

TO BE STAMPED OR MARKED WHERE INDICATED (THUS # (LETTERS)

PILOT SAMPLE SHOULD BE APPROVED BY A H S P BEFORE BULK PRODUCTION.

6.*1 DIMENSION FOR REFERENCE.

5.* DIMENSIONS ARE TO BE ENSURED BY TOOL.

4. IN BENT SECTIONS NATURAL THINNING OF METAL IS ALLOWED.

3. DRAFTS SHRINKAGE OF EDGES AND PRESSING MARKS ARE ALLOWED.

TO BE CHECKED IN BLANK.

AS PER THE TRUE DIMENSIONS SHOULD NOT BE MORE THAN 1 mm.

2. DEVIATION OF COMPONENT CONTOUR FROM TEMPLATE CONSTRUCTED

1. ALTERNATE MATERIAL SHEET
5.0 GOST 19903-74
20, GOST 1577-70
AND SHEET 5.0 GOST 19903-74
0.9 2-2 GOST 19282-73

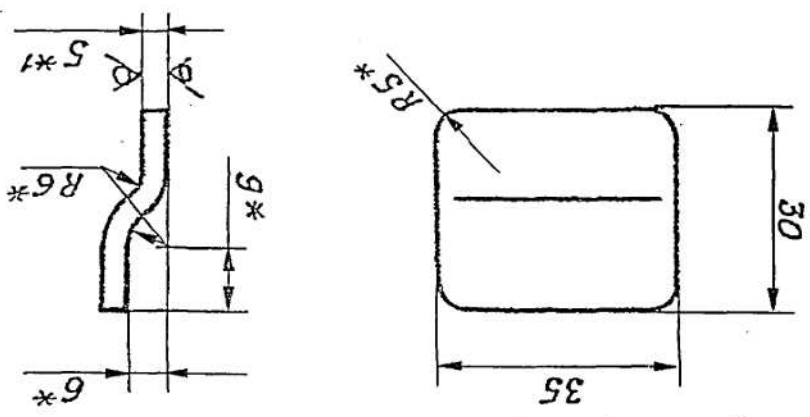

UNLESS OTHERWISE SPECIFIED Rz 500

SHEET No. 1 OF 1

DRAWING NUMBER 155.29.3039

F-133
76

*COMMON TO T-90° & BLT
DRAWING RE-INDIANISED BASED ON RUSSIAN ORIGINAL ISSUE-NIL (R.BALAKRISHNAN), JTDID
29-08-08

R. Balakrishnan

1 2 3 4

DRAWING NUMBER
172.04.148cb-1Cb

SHEET No. 1 OF 1

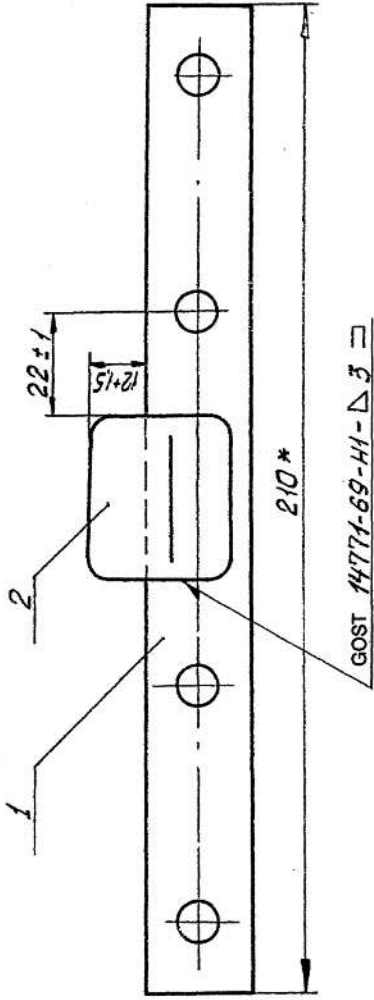

1. PROJECTION AND SINKING OF WELD BEYOND PLANE "A" SHOULD NOT EXCEED 1.5 mm.

GRINDING OF WELD JOINT IS ALLOWED.

② - PAINT-COATING IN ACCORDANCE WITH SPECIFICATIONS 172.TV.2.2.

② 2. COATING PRIMER (100-03 K KHAKI ENAMEL XB - 510 REQUIREMENTS AS PER 520 TY 5.

3 WELDS ARE TO BE CARRIED OUT BY SEMI-AUTOMATIC GAS-SHIELDED ARC WELDING.

4. * DIMENSIONS FOR REFERENCE.

- 172.04.106Cb-2
- 172.04.107Cb-A
- 172.04.131Cb-A
- 172.04.132Cb-A
- 172.04.144Cb-A
- 172.04.145Cb-A
- 172.04.160Cb-A
- 172.04.161Cb-A
- 184.04.011cbCb
- 184.04.012cbCb
- 184.04.013cbCb
- 184.04.014cbCb
- ②A { CQAIHV/5.04.023
- ②B { CQAIHV/5.04.033

DRN	Sd/=	MATERIAL:-	USED ON:-
CHD	Sd/=		SEE ABOVE
APPD	Sd/=		
DATE	21.03.88		
SCALE:-	1 : 1		
DIMENSIONS IN mm		CONTROLLERATE OF QUALITY ASSURANCE (HEAVY VEHICLES)	
TOLERANCE ON DIMMS		AVADI	
UNLESS OTHERWISE		TITLE:-	
STATED IS: 2102-69		STRAP ASSY.	
ALL THREADS TO		D S CAT NUMBER	
CONFORM TO		DRAWING NUMBER	
NATURE OF AMENDMENTS		172.04.148cb-1Cb	
ISSUE	DATE		
2B	30.9.19	N of A No. CQAIHV/T-90/04/004	
	DT. 30.09.2019		
2A	09.10.03	N OF A No. CQA(HV)/T-90/04/001	
2	27.06.90	172M 748 'A-88. (AL.11/3)	
EST. WT. (KG)		TO BE STAMPED OR MARKED WHERE	
0.135		INDICATED THUS # (LETTERS)	
ALL SHARP EDGES AND CORNERS TO BE REMOVED UNLESS OTHERWISE STATED MACHINED CORNERS TO HAVE R OUT-SIDE R INSIDE EQUIVALENT CHAMFERS ARE PERMISSIBLE.			

26-06-08
B.JAYARAJU, TTDI

* COMMON TO T-90 & BLT
DRAWING RE - INDIANISED BASED ON RUSSIAN ORIGINAL ISSUE - 1

F-20
52
SIZE A3

SIZE A4

DATE 18-3-88

APPROVED BY: [Signature]

TCD [Signature]

CHD [Signature]

DRN [Signature]

ISSUE DATE

NATURE OF AMENDMENTS

SCALE: 1:1

DIMENSIONS IN mm

TOLERANCE ON DIMENSIONS UNLESS OTHERWISE STATED IS 2102-69 ALL THREADS CONFORM TO

DATE

DATE

DATE

DATE

DATE

DATE

DATE

DATE

DATE

DATE

DATE

DATE

DATE

DATE

DATE

DATE

DATE

DATE

DATE

DATE

DATE

DATE

F-24
85

COMMON TO BLT

172 04 418-1

DRAWING NUMBER

D S CAT NUMBER

STRAP

TITLE

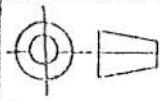

TOLERANCE ON DIMENSIONS UNLESS OTHERWISE STATED IS 2102-69 ALL THREADS CONFORM TO

CONTROL RATE OF QUALITY ASSURANCE (HEAVY VEHICLES) AVADI

4-II-15-GOST 16523-70

3.0 GOST 19903-74

MATERIAL:- SHEET

USED ON 172 04 148GB-1

ALL SHARP EDGES AND CORNERS TO BE REMOVED UNLESS OTHERWISE STATED MACHINED CORNERS TO HAVE R OUT-SIDE R INSIDE EQUIVALENT CHAMFERS ARE PERMISSIBLE.

EST. WT. 0.10 kg

TO BE STAMPED OR MARKED WHERE INDICATED THUS # (LETTERS)

PILOT SAMPLE SHOULD BE APPROVED BY A H S P BEFORE BULK PRODUCTION.

- 1. ALTERNATIVE MATERIAL : SHEET 3.0 GOST 19903-74 4-II 20 GOST 16523-70
- 2. ROUNDING OFF CORNERS UP TO R 5mm IS ALLOWED.
- 3. OTHER REQUIREMENTS IN ACCORDANCE WITH 520 TY-1
- * DIMENSION FOR REFERENCE.

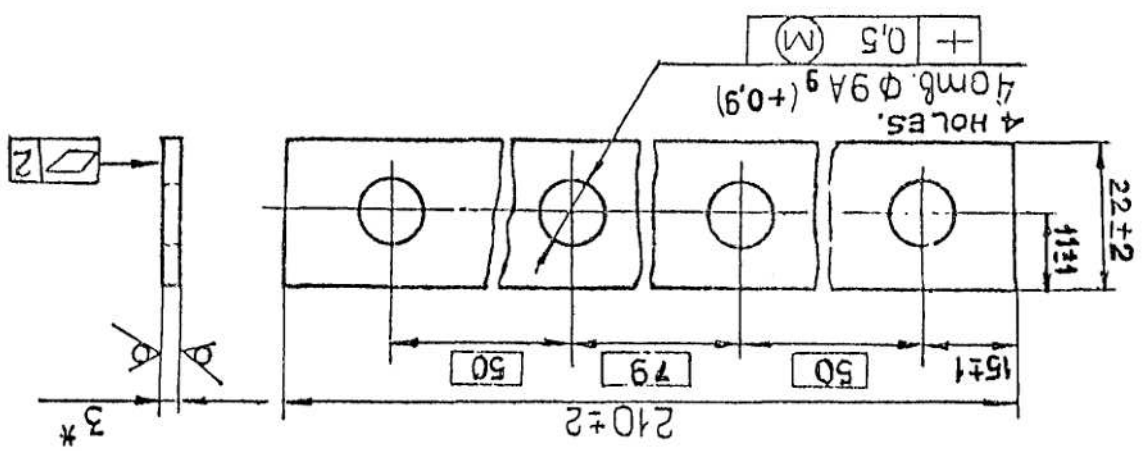

UNLESS OTHERWISE SPECIFIED RZ 320 (✓)

172 04 418-1

DRAWING NUMBER

F-20
 COMMON TO T-90 & BLT
 I/L RE-CREATED BASED ON RUSSIAN ORIGINAL ISSUE - 1
 (R. BALAKRISHNAN)
 J70 (D) 20 OCT 08

(2B) COA(HV)5.04.023
 (2A) COA(HV)5.04.033
 184 04 011CECB
 184 04 012CECB
 184 04 013CECB
 184 04 014CECB

172.04.145CB-A
 172.04.160CB-A
 172.04.161CB-A
 172.04.106Cb-2
 172.04.107Cb-A
 172.04.131Cb-A
 172.04.132Cb-A
 172.04.144Cb-A

ZONE	ITEM NO	DRAWING NUMBER	D S CAT NUMBER	DESCRIPTION	QTY	REMARKS
		172.04.148cb-1Cb		STRAP ASSY.		
		& ITEM LIST				
	1	172.04.418-1		STRAP	1	
	2	155.29.3039		CLAMP	1	
ISSUE	DATE	NATURE OF AMENDMENTS	ISSUE	DATE	NATURE OF AMENDMENTS	
2B	30.09.19	N OF A No. COA(HV)/T-90/04/004 DT. 30.09.2019				
2A	9.10.03	N OF A No. COA(HV)/T90/04/001				
2	27.6.90	DRG. AMENDED.				
DRN	Sd/=	CONTROLERATE OF QUALITY ASSURANCE (HEAVY VEHICLES) AVADI.				
CHD	Sd/=	TITLE:				
APPD	Sd/=	STRAP ASSY.				
DATE	21.03.88	SHT. NO. 1 OF 1	D S CAT NUMBER	ITEM LIST FOR 172.04.148cb-1Cb		