

PLACE FOR INSPECTION MARKING

PROOF LOAD : 350 kgf
(3430 N)

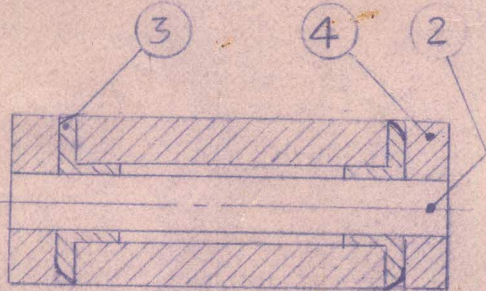
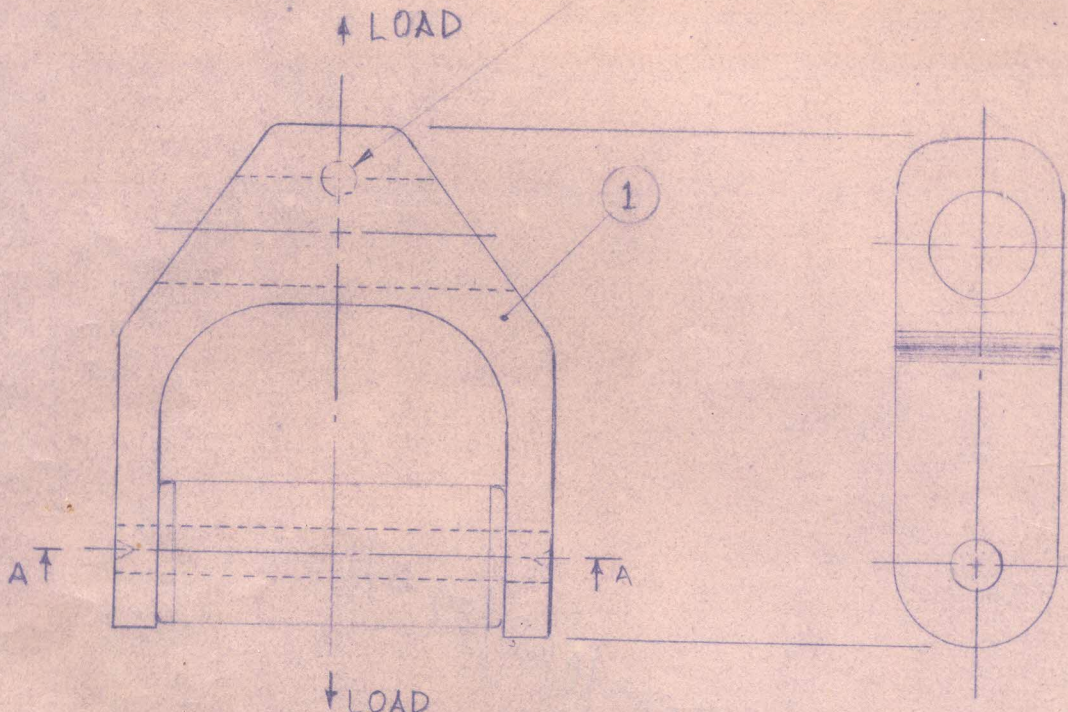

SECTION-AA

APPROVED
[Signature]

4	ROLLER	1	5
3	BUSH	2	4
2	CENTRAL PIN	1	3
1	BODY	1	2
-	ASSEMBLY	-1	1
DETAIL No.	NOMENCLATURE	No. OFF	SHEET No.

DETAIL INDEX

Q	17-12-99	D4	ADRDE/PAS/AEP/ 57/B, DT. 13-12-99	PLACE FOR INSPECTION MARKING INDICATED	<i>[Signature]</i>	<i>[Signature]</i>
R. No.	DATE	ZONE	AUTHORITY	BRIEF RECORD	O/C DES	HEAD QA
DRN	<i>[Signature]</i>	DRD	MATERIAL:-	ADDRDE, AGRA		
CHD	<i>[Signature]</i>	<i>[Signature]</i>	FINISH:- BLACK STOVING PAINT			
TRD		O/C	HEAT TREATMENT	APPROVED		
COMP		PGD		<i>[Signature]</i>		
SCALE:- 1:1	PROJ. OFFR.	<i>[Signature]</i>		PROG. DIRECTOR (Q.A.)		
DIMENSIONS ARE IN MM	DIV. HEAD	<i>[Signature]</i>		DRG. No. (a)		
TOLERANCE				ADRDE/1359		
IS: 2102 COARSE				DRD/25/98		

ASSEMBLY
INVERTED-V

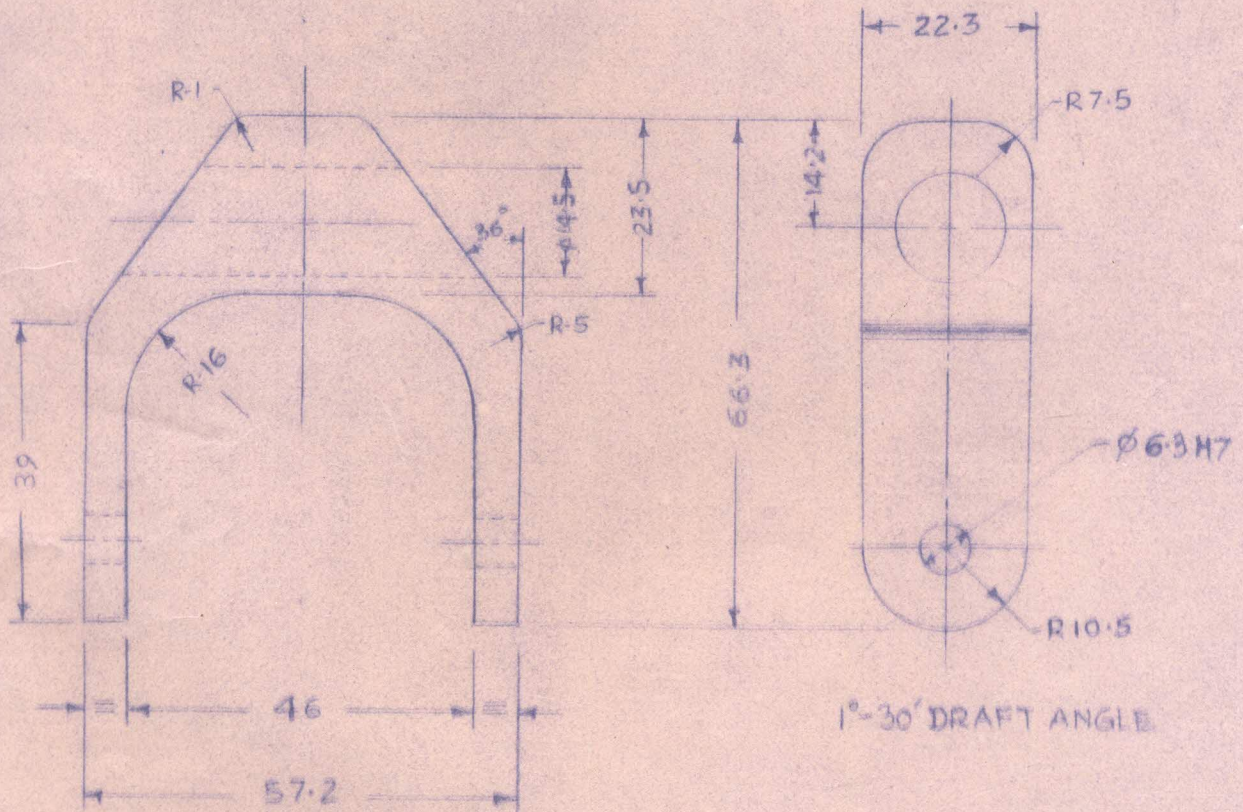

APPROVED
[Signature]

R. No.	DATE	ZONE	AUTHORITY	BRIEF RECORD		o/c	PGD	
DRN	<i>[Signature]</i>		DRD	MATERIAL: A1 ALLOY TO SPEC. IS: 738	ADDRDE, AGRA			
CHD	<i>[Signature]</i>			HE-14 IN W CONDITION				
TRD				FINISH: ANODISED TO A THICKNESS OF 0.015 mm AS PER IS: 1868 & DIED BLACK				
COMP			o/c	PGD	HEAT TREATMENT: -	APPROVED		
SCALE: 1:1	PROJ. OFFR. <i>[Signature]</i>		DIV. HEAD <i>[Signature]</i>		HARDNESS 140-160 VPN	<i>[Signature]</i> PROG. DIRECTOR (Q.A.)		
DIMENSIONS ARE IN mm	BODY INVERTED-V						DRG. No. (a) ADDRDE/1359	
TOLERANCE IS: 2102 COARSE							DRD/25/98	

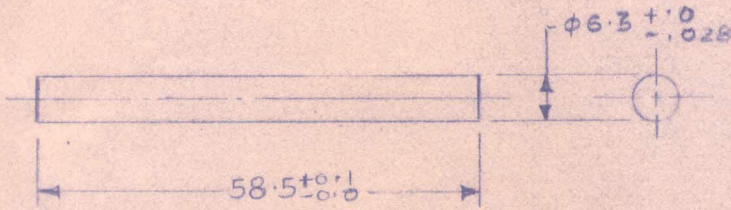

APPROVED
[Signature]

R.No		DATE	ZONE	AUTHORITY	BRIEF RECORD		o/c	PGD
DRN	<i>[Signature]</i>	DRD		MATERIAL:-AUST STEEL AISI 304, 85:970 IN ANNEALED CONDITION.		ADRDE; AGRA		
CHD	<i>[Signature]</i>	<i>[Signature]</i>	<i>[Signature]</i>	FINISH:- NI-CV PLATING, 0.02mm THICK AS PER IS 4942-1983				
TRD		o/c	PGD	HEAT TREATMENT:-		APPROVED <i>[Signature]</i>		
COMP		PROJ OFFR	<i>[Signature]</i>	DIV HEAD <i>[Signature]</i>		PROG. DIRECTOR (Q.A.) DRG. No. (a) ADRDE/1359 DRD/25/98		
SCALE:- 1:1		CENTRAL PIN INVERTED - V						
DIMENSIONS ARE IN MM								
TOLERANCE:- IS:2102 COARSE								

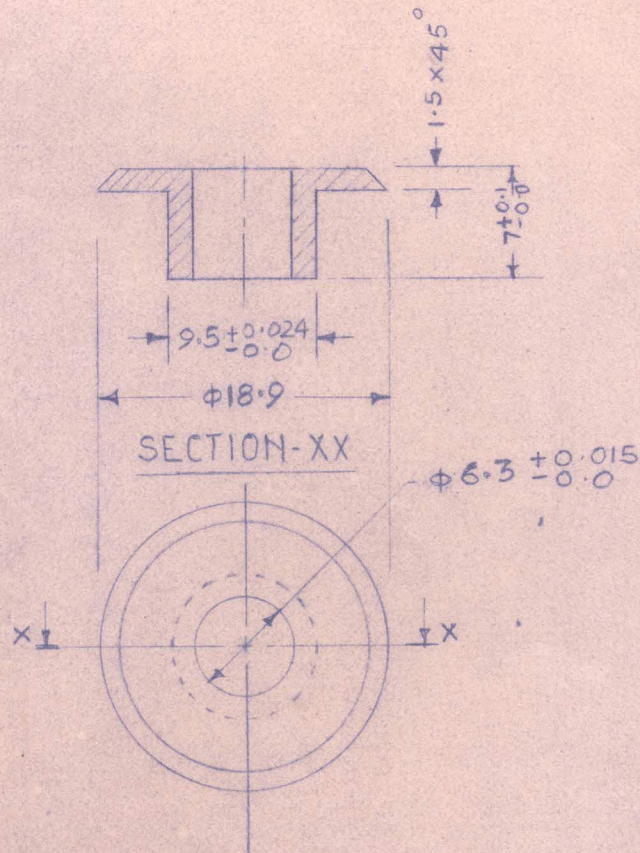

APPROVED
Me

R.No.	DATE	ZONE	AUTHORITY	BRIEF RECORD	o/c PGD
-------	------	------	-----------	--------------	---------

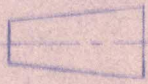
DRN	<i>Prishu</i>	DRD	MATERIAL :- PHOSPHAR BRONZE AS PER IS: 7811-1985	ADRDE; AGRA  
CHD	<i>Prishu</i>	o/c	FINISH :- NI-CR PLATED AS PER IS: 4942-0.02mm THICK	
TRD	<i>Prishu</i>	PGD	HEAT TREATMENT :-	
COMP	<i>Prishu</i>	<i>Prishu</i>		

SCALE :- 2:1	PROJ OFFR	<i>Prishu</i>	APPROVED
	DIV HEAD	<i>Prishu</i>	<i>Prishu</i>

DIMENSIONS ARE IN MM	<u>BUSH</u> <u>INVERTED-V</u>	PRDG DIRECTOR (GA)
TOLERANCE :-		DRG. No. (0)
IS: 2102 COARSE OTHER THAN SPECIFIED		ADRDE/1359

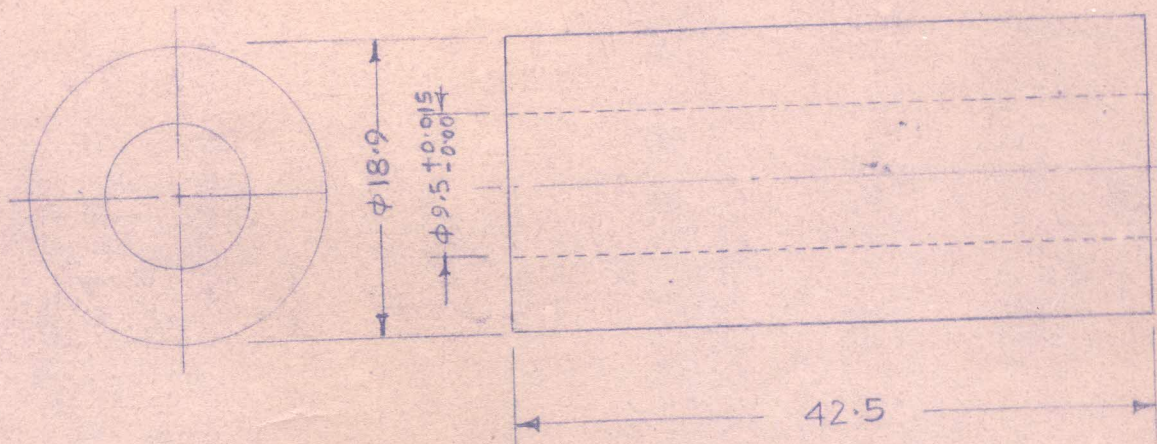

APPROVED
[Signature]

A

B

C

D

R.No	DATE	ZONE	AUTHORITY	BRIEF RECORD	o/c	PGD
------	------	------	-----------	--------------	-----	-----

DRW <i>[Signature]</i>	DRD		MATERIAL:-AL. ALLOY TO SPECN IS: 733, HE-14 IN 'W' CONDITION.	ADRDE, AGRA	
END 24/2/2014	<i>[Signature]</i>	<i>[Signature]</i>	FINISH:- ANODISED TO 0.015 MM THICKNESS SPECN. IS: 1868-1961 & DIED BLACK		
TRD	o/c	PGD			
COMP	PROJ OFFR. <i>[Signature]</i>	DIV HEAD <i>[Signature]</i>	HEAT TREATMENT:- HARDNESS 140-160 YPN	APPROVED <i>[Signature]</i>	
SCALE:- 2:1	<u>ROLLER</u> <u>INVERTED-V</u>			PROG DIRECTOR (Q/A)	
DIMENSIONS ARE IN MM				DRG No. (a)	
TOLERANCE:- IS: 2102, COARSE				ADRDE/1359	
DRD/25/08					



F PACKING CLAUSE:-

EACH INVERTED-V SHALL BE PACKED IN A POLYTHENE BAG OF SUITABLE SIZE AND TIED. THE MOUTH OF THE BAG TO BE HEAT - SEALED 20 NOS. THIS SEALED BAG SHALL BE PACKED IN A SUITABLE SIZE OF CARTON 10 NOS. OF SUCH CARTONS SHALL BE PACKED IN A C.W.P (DULY LINED WITH PAPER PACKING WATER PROOF) ONE INVERTED-V IN EACH CARTON SHALL BE IDENTIFIED BY A LABEL SHOWING CAT. NO, DESIGNATION OF THE STORE AND ALSO THE RECOGNISED INITIALS OF THE - MANUFACTURER. THE PACKING CASE SHALL BE LEGIBLY AND INDELIBLY MARKED WITH THE ADDRESS OF THE CONSIGNEE, CONSIGNOR, CAT. NO, NOMENCLATURE OF THE STORE, THE YEAR OF MANUFACTURE, TOTAL NO OF PACKING CASES AND THE NO. OF INDIVIDUAL PACKING CASE IN A CONSIGNMENT

APPROVED
[Signature]

B										
Q	17-12-99	F4	ADRDE/PAS/AEP/ 57/B, DT.13-12-99	PACKING CLAUSE INCLUDED AS SHEET No.6				<i>[Signature]</i>	<i>[Signature]</i>	
R.No	DATE	ZONE	AUTHORITY	BRIEF RECORD				OVC DES	HEAD (Q.A)	
SCALE:-			ADRDE, AGRA	DRN	<i>com</i>	PROJ. OFFR				
DIMENSION IN mm.			GROUP:-	CHD	<i>Silakam</i>	GROUP DIR				
TOL.				<i>[Signature]</i> OVC DES APPROVED <i>[Signature]</i> HEAD(Q.A)						
MATERIAL PROCESS:-			PACKING CLAUSE INVERTED - V						DRG. NO ADRDE/ 1355 (a)	
FINISH:-									PROJ NO DRD/35/98	
HEAT TREATMENT:-										