

ITEM NO.	PART NUMBER	DESCRIPTION	QTY.
1	M-7301 BODY, TRIGGER BAR PIN (7313104)	BODY, TRIGGER BAR PIN, 00W50BMG	1
2	M-7302 LOCK, TRIGGER BAR PIN (7313105)	LOCK, TRIGGER BAR PIN, 00W50BMG	1

REVISIONS				
ZONE	REV.	DESCRIPTION	DATE	APPROVED
	A	CREATE DRAWING	4/29/2015	G. HERSHBERGER

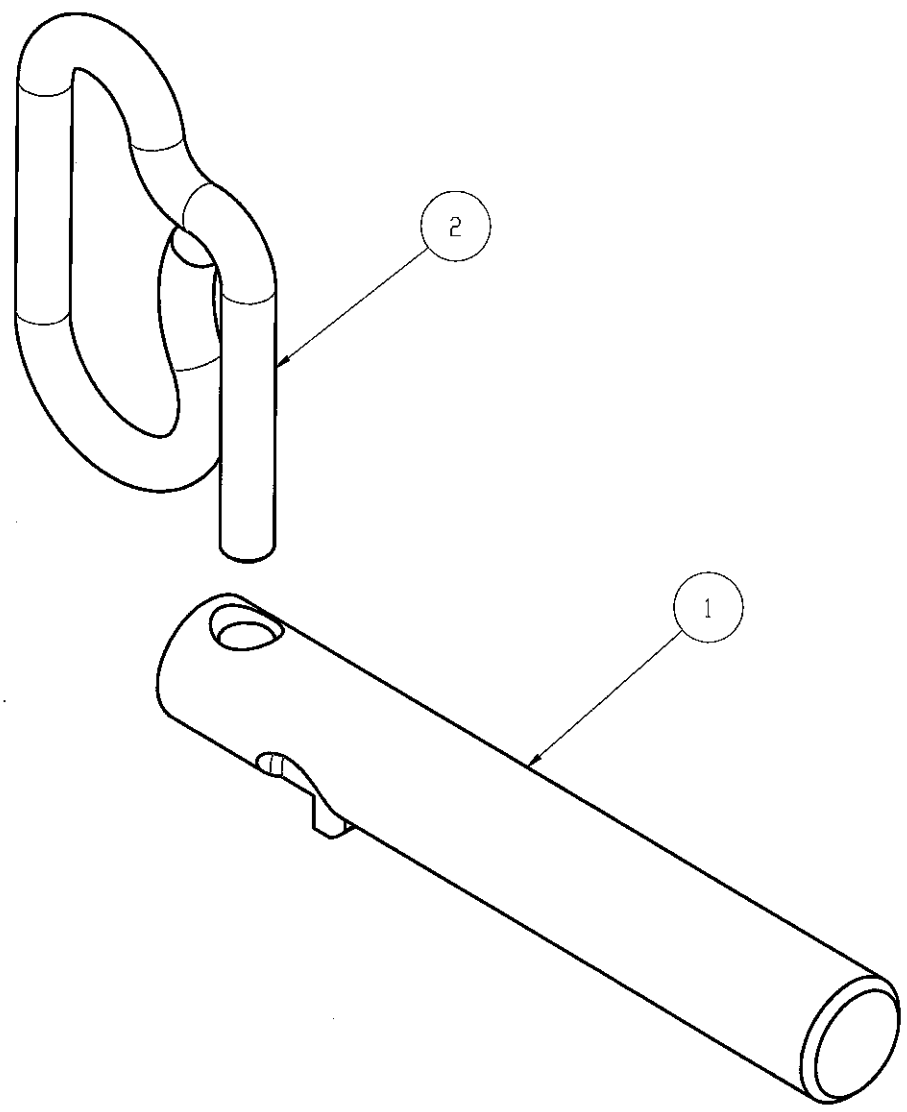

अंतरिम रूप से प्रमाणित
Provisionally Approved

24 AUG 2021

दिनांक

हस्ताक्षर/Sig
Ror Conde (AP)

ITAR CONTROLLED THIS DOCUMENT IS CONTROLLED UNDER THE ITAR IT MAY NOT BE PROVIDED TO A NON-US RESIDENT WITHOUT THE WRITTEN APPROVAL OF THE US GOVT. VIOLATIONS WILL RESULT IN CIVIL OR CRIMINAL PENALTIES. PROPRIETARY AND CONFIDENTIAL THE INFORMATION CONTAINED IN THIS DRAWING IS THE SOLE PROPERTY OF OHIO ORDNANCE WORKS, INC. ANY REPRODUCTION IN PART OR AS A WHOLE WITHOUT THE WRITTEN PERMISSION OF OHIO ORDNANCE WORKS, INC. IS PROHIBITED.	UNLESS OTHERWISE SPECIFIED DIMENSIONS ARE IN MM/INCHES ALL THREAD DIM. ARE IN INCHES	NAME	DATE	OHIO ORDNANCE WORKS, INC. PIN ASSEMBLY, TRIGGER BAR, 00W50BMG	
	TOLERANCES: FRACTIONAL ANGULAR HACH ± BEND TWO PLACE DECIMAL ±0.25 THREE PLACE DECIMAL ±0.127	DRAWN	PMD		04/28/15
	INTERPRET GEOMETRIC TOLERANCING PER MATERIAL	CHECKED			
	FINISH	ENG APPR.			
DO NOT SCALE DRAWING	MFG APPR.			SIZE C	
	COMMENTS:			SCALE: 4:1 WEIGHT: SHEET 1 OF 2	
				REV A	

M
7300

M
7300

REVISIONS				
ZONE	REV.	DESCRIPTION	DATE	APPROVED
-	-	See Sheet1	-	-

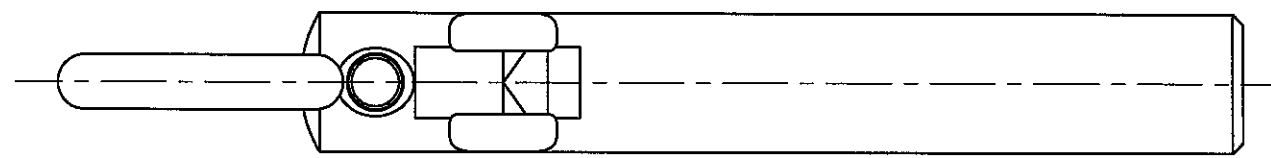
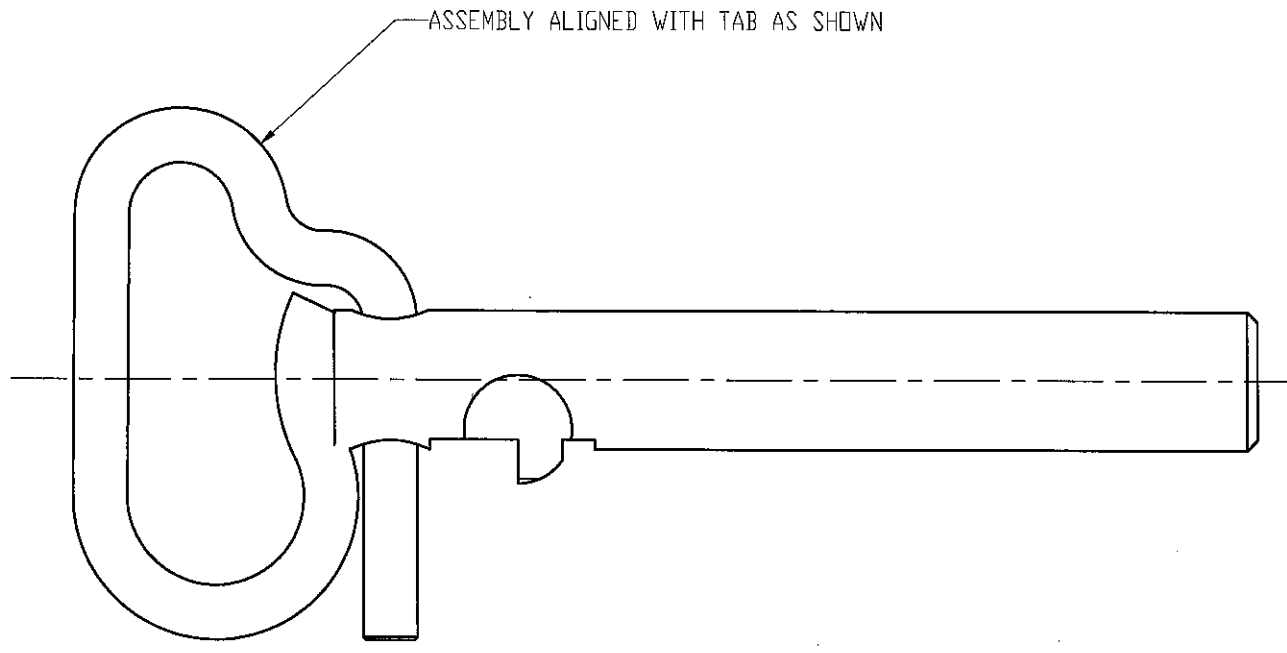
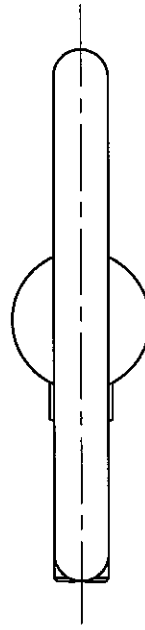

अंतरिम रूप से प्रमाणित
Provisionally Approved
24 AUG 2021
दिनांक
हस्ताक्षर/Sig
Per Chade (AP1)

ITAR CONTROLLED THIS DOCUMENT IS CONTROLLED UNDER THE ITAR. IT MAY NOT BE PROVIDED TO A NON-US RESIDENT WITHOUT THE WRITTEN APPROVAL OF THE U.S. GOV'T. VIOLATIONS WILL RESULT IN CIVIL OR CRIMINAL PENALTIES. PROPRIETARY AND CONFIDENTIAL THE INFORMATION CONTAINED IN THIS DRAWING IS THE SOLE PROPERTY OF OHIO DRONNAGE WORKS, INC. ANY REPRODUCTION IN PART OR AS A WHOLE WITHOUT THE WRITTEN PERMISSION OF OHIO DRONNAGE WORKS, INC. IS PROHIBITED.	UNLESS OTHERWISE SPECIFIED	NAME	DATE	OHIO DRONNAGE WORKS, INC. PIN ASSEMBLY, TRIGGER BAR, DDW50BMG	
	DIMENSIONS ARE IN INCHES ALL THREAD DIA. ARE IN INCHES TOLERANCES:	DRAWN	PMD		04/28/15
	FRACTIONAL ANGULAR HORN & BEND TWO PLACE DECIMAL #0.25 THREE PLACE DECIMAL #0.127	CHECKED			
	INTERPRET GEOMETRIC TOLERANCING PER:	ENG APPR.			
	MATERIAL	COMMENTS:		SIZE	
	FINISH			C	
	DO NOT SCALE DRAWING			7313106	
				REV	
				A	
				SCALE: 4:1 WEIGHT: SHEET 2 OF 2	

M
7301

NOTES:

1. FINISH $\sqrt{3.2}$ ALL OVER.
2. BREAK ALL EDGES 0.076 +0.305 UNLESS OTHERWISE SPECIFIED.
3. MATERIAL: STEEL, ASTM A108; 1022, 1018 OR ASTM A576; 1022, 1018.
4. HEAT TREATMENT: CARBURIZE AT 857- 871° C. TO CASE DEPTH 0.203 TO 0.305. OIL QUENCH. TEMPER ONE HOUR MINIMUM TO HARDNESS SPECIFIED (RH 15N86-89).
5. FINAL PROTECTIVE FINISH: FINISH 5.3.1.2 OR 5.3.2.2 OF MIL-STD-171.
6. * THESE DIMENSIONS NOT TO BE CHANGED WITHOUT FIRST CHECKING WITH AIR FORCE TOP PLATE SOLENOID CONDITIONS.
7. ASME Y14.5M-1994 APPLIES.

REVISIONS				
ZONE	REV.	DESCRIPTION	DATE	APPROVED
	A	CREATE DRAWING	4/29/2015	G. HERSHBERGER

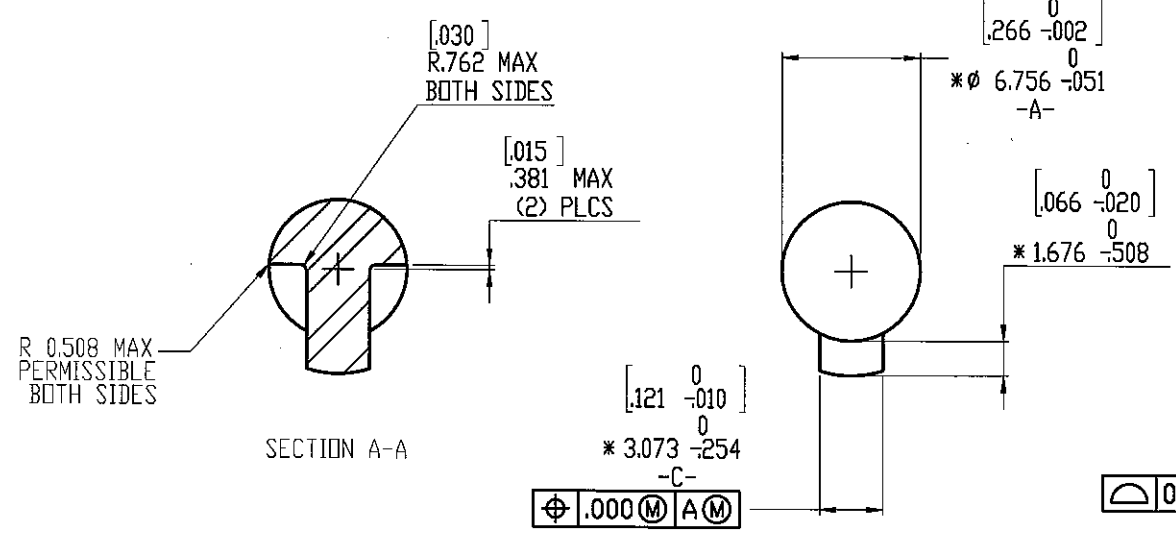
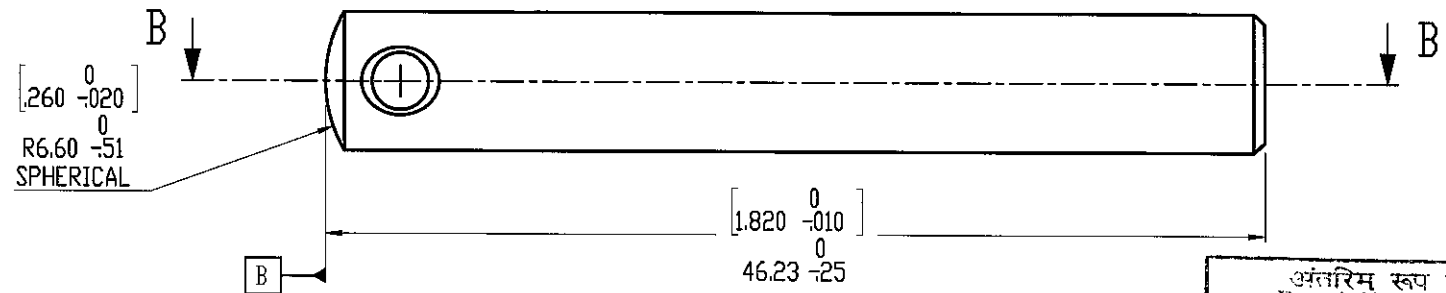
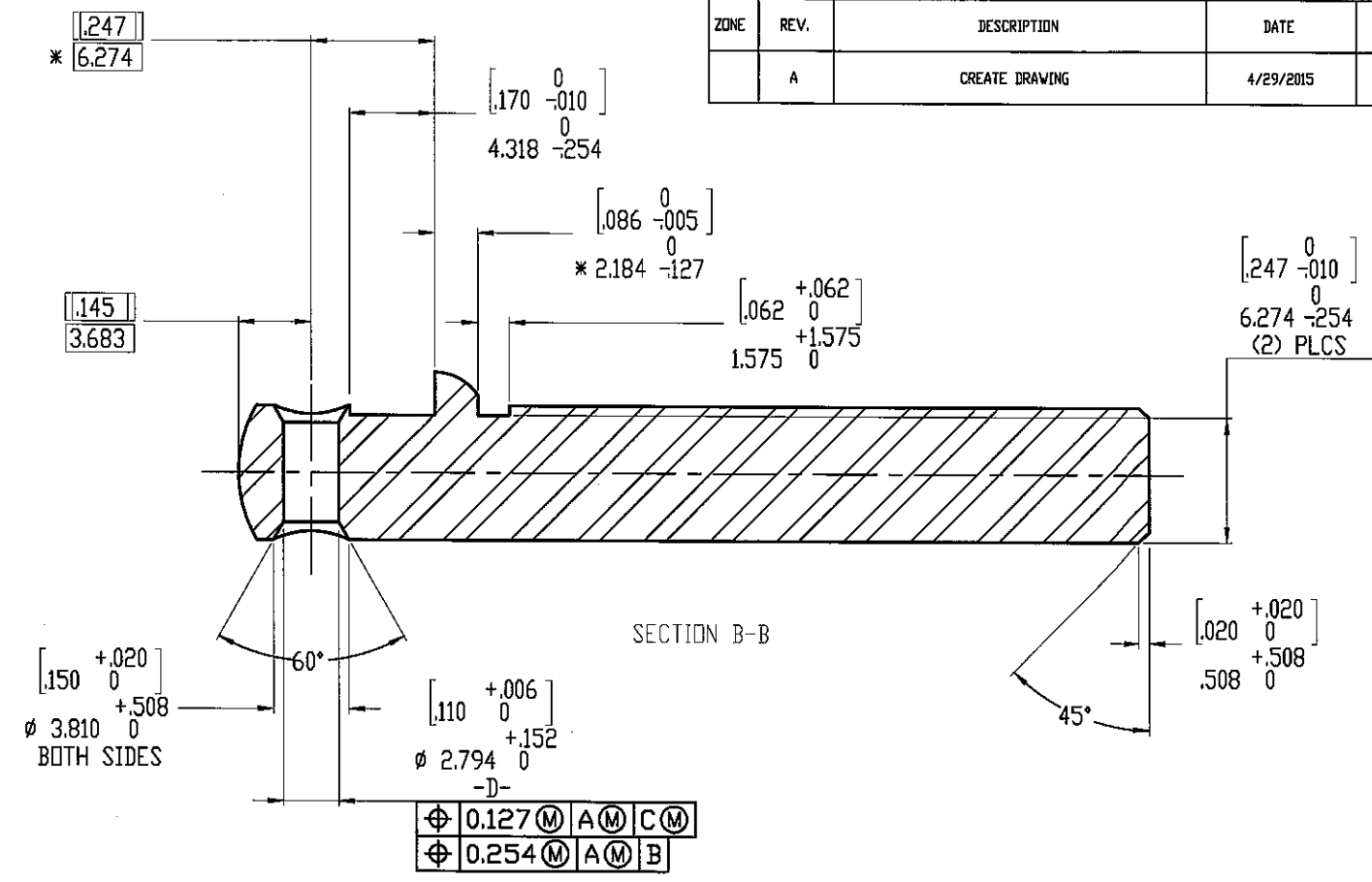

अंतरिम रूप से प्रमाणित
Provisionally Approved
24 AUG 2021
दिनांक
हस्ताक्षर/Sig
K. Amdele

ITAR CONTROLLED THIS DOCUMENT IS CONTROLLED UNDER THE EAR. IT MAY NOT BE PROVIDED TO A NON-US RESIDENT WITHOUT THE WRITTEN APPROVAL OF THE U.S. GOVT. VIOLATIONS WILL RESULT IN CIVIL OR CRIMINAL PENALTIES. PROPRIETARY AND CONFIDENTIAL THE INFORMATION CONTAINED IN THIS DRAWING IS THE SOLE PROPERTY OF OHIO ORDNANCE WORKS, INC. ANY REPRODUCTION IN PART OR AS A WHOLE WITHOUT THE WRITTEN PERMISSION OF OHIO ORDNANCE WORKS, INC. IS PROHIBITED.	UNLESS OTHERWISE SPECIFIED	NAME	DATE	OHIO ORDNANCE WORKS, INC.	
	DIMENSIONS ARE IN MM/INCHES. ALL THREAD DIM. ARE IN INCHES. TOLERANCES: FRACTIONAL ANGULAR MATCH ±2° BEND TWO PLACE DECIMAL ±0.25 THREE PLACE DECIMAL ±0.127	DRAWN	PHD		04/28/15
	INTERPRET GEOMETRIC TOLERANCING PER MATERIAL	CHECKED			
	FINISH	ENG APPR.			
DO NOT SCALE DRAWING	MFG APPR.			BODY, TRIGGER BAR PIN, 00W50BMG SIZE C 7313104 REV A SCALE: 4:1 WEIGHT: SHEET 1 OF 1	

M
7302

REVISIONS				
ZONE	REV.	DESCRIPTION	DATE	APPROVED
	A	CREATE DRAWING	4/29/2015	G. HERSHBERGER

NOTES:

1. FINISH $\sqrt{32}$ ALL OVER, EXCEPT SHEARED EDGES $\sqrt{6.3}$
2. BREAK EDGES 0.076 +0.305 UNLESS OTHERWISE SPECIFIED.
3. HEAT TREATMENT: HEAT AT 787C TO 816 ° C. OIL QUENCH, TEMPER 1 HOUR MINIMUM TO HARDNESS SPECIFIED (RH 15N 83-85.5).
4. FINAL PROTECTIVE FINISH: FINISH 5.3.1.2 OR 5.3.2.2 OF MIL-STD-171.
5. ASME Y14.5M-1994 APPLIES.
6. PERFECT FORM AT MMC NOT REQUIRED.
7. MATERIAL: STEEL 1060-1095 PER ASTM A576 OR ASTM A510 OR STEEL, ASTM A686: CLASS W1-8 THRU 9, GRADE C.

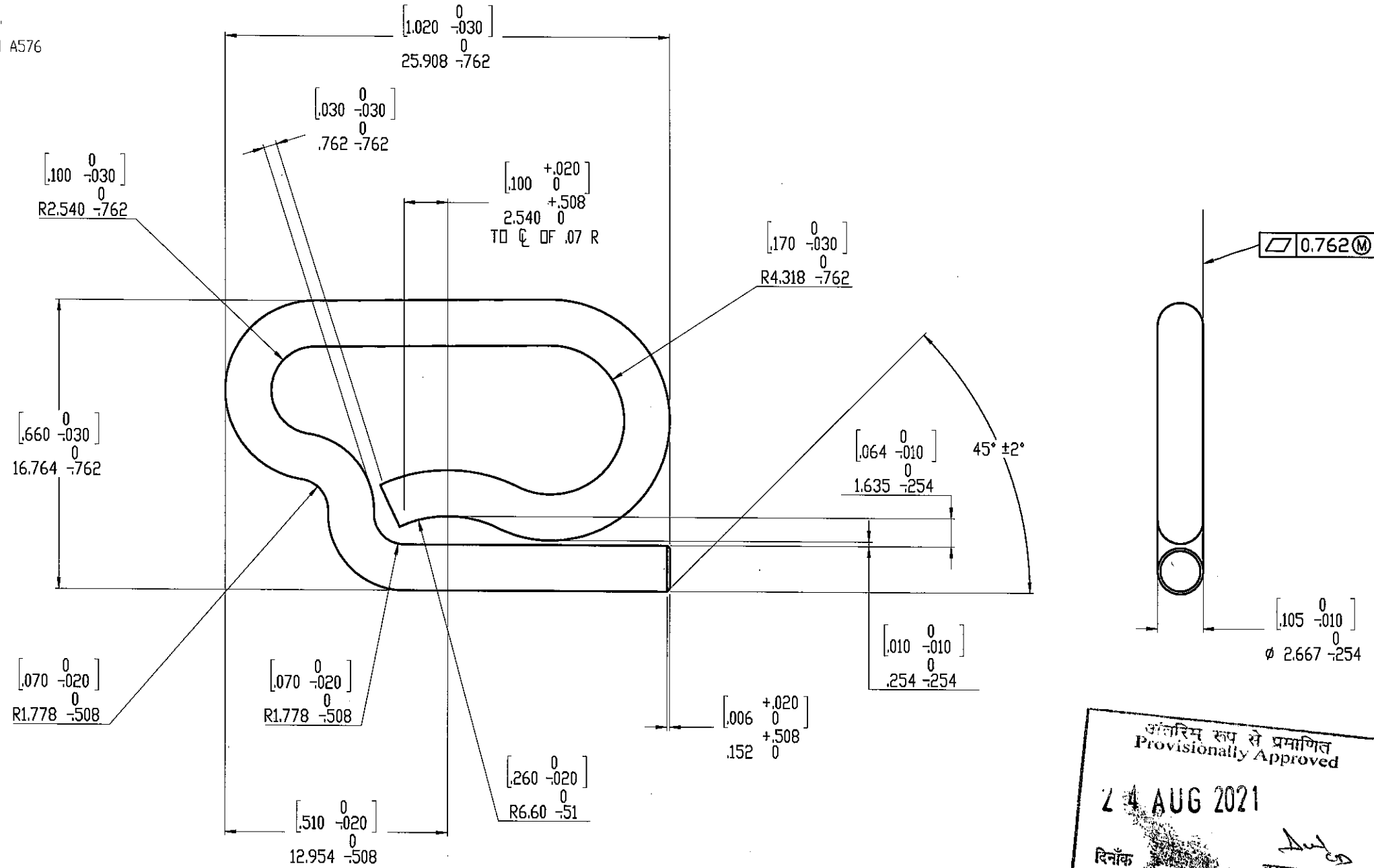

अंतरिम रूप से प्रमाणित
Provisionally Approved
24 AUG 2021
दिनांक
हस्ताक्षर/Sig
Roshan K

ITAR CONTROLLED THIS DOCUMENT IS CONTROLLED UNDER THE ITAR. IT MAY NOT BE PROVIDED TO A NON-U.S. RESIDENT WITHOUT THE WRITTEN APPROVAL OF THE U.S. GOVT. VIOLATIONS WILL RESULT IN CIVIL OR CRIMINAL PENALTIES. PROPRIETARY AND CONFIDENTIAL THE INFORMATION CONTAINED IN THIS DRAWING IS THE SOLE PROPERTY OF OHIO ORDNANCE WORKS, INC. ANY REPRODUCTION IN PART OR AS A WHOLE WITHOUT THE WRITTEN PERMISSION OF OHIO ORDNANCE WORKS, INC. IS PROHIBITED.	UNLESS OTHERWISE SPECIFIED	NAME	DATE	OHIO ORDNANCE WORKS, INC.	
	DIMENSIONS ARE IN INCHES (FRACTIONAL)	DRAWN	PMD		04/28/15
	ALL THREAD DIM. ARE IN INCHES	CHECKED			
	TOLERANCES: FRACTIONAL: ANGULAR: MACH ± BEND TWO PLACE DECIMAL ±0.25 THREE PLACE DECIMAL ±0.127	ENG APPR.			
	INTERPRET GEOMETRIC TOLERANCING PER:	MFG APPR.			
	MATERIAL:	QA			
	FINISH:	COMMENTS:			
	DO NOT SCALE DRAWING				

LOCK, TRIGGER BAR PIN, 00W50BMG
 SIZE C 7313105 REV A
 SCALE: 5:1 WEIGHT: SHEET 1 OF 1