

MATERIAL : AISI / SAE 4630, MINM 4630 OR EQUIVALENT
 HARDNESS : 83-86 HR 15N
 SUPPLY CONDITION : MANGANESE PHOSPHATED

NOTE:-
 1. ALL DIMENSIONS ARE IN MM.
 2. GENERAL TOLERANCES ARE AS PER ISO 2768 (M).

HOS / MPM
 प्रमाणित मॉड / CERTIFIED COPY
 डाटा / लेआउट / गेज शेड्यूल
 DRG/LAYOUT/GAUGE SCHEDULE
 तिनांक / AT THIS DATE 15.10.2017
 श्री श्री सी / CDD
 राइफल कार्ट्री, इशारपुर
 RIFLE FACTORY, ISHAPUR

EJECTOR
 (THROUGH MIN ROUTE)
 DRG. REF. NO. - D.S.CAT 1005-003156
 DRG. NO. - RF. SK 10121

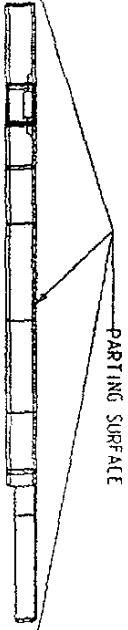

PARTING SURFACE

PARTING LINE MARKS
MISMATCH 0.05 MAX.
(WILL BE WITHIN THE
TOLERANCE SPECIFICATION)

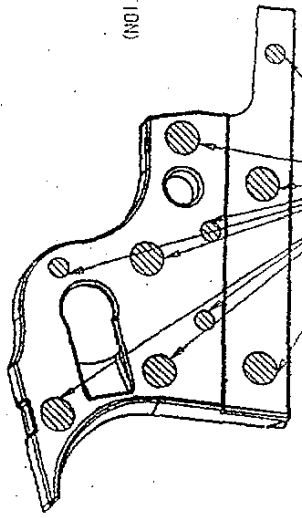

EJECTOR PIN MARKS
DEPRESSION 0.1 MAX.

CAVITY ID MARK AS #12...
DEPRESSION 0.2 MAX.
(APPLICABLE FOR MULTI CAVITY)

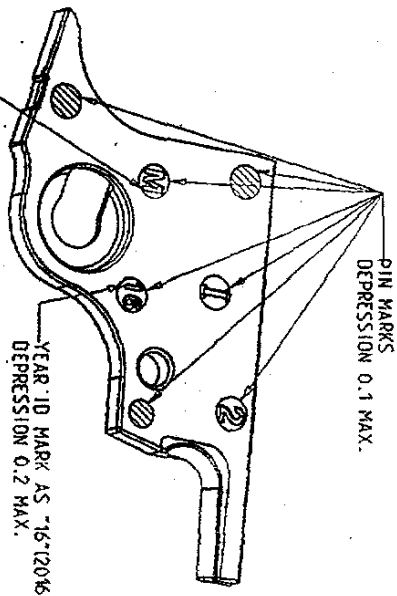

PIN MARKS
DEPRESSION 0.1 MAX.

MIM PROCESS ID MARK
AS "M" DEPRESSION
0.2 MAX

YEAR ID MARK AS "16"(2016)
DEPRESSION 0.2 MAX.

MANUFACTURING ID MARK
AS "T"
DEPRESSION 0.2 MAX.

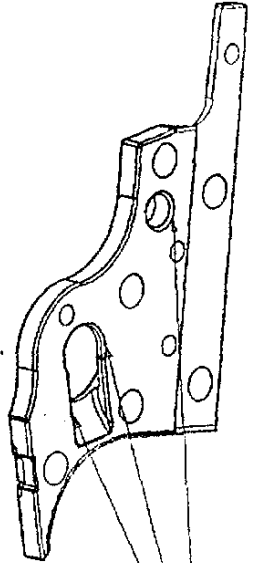

INSERT LINE MARKS
MISMATCH 0.05 MAX.
(WILL BE WITHIN THE
TOLERANCE SPECIFICATION)

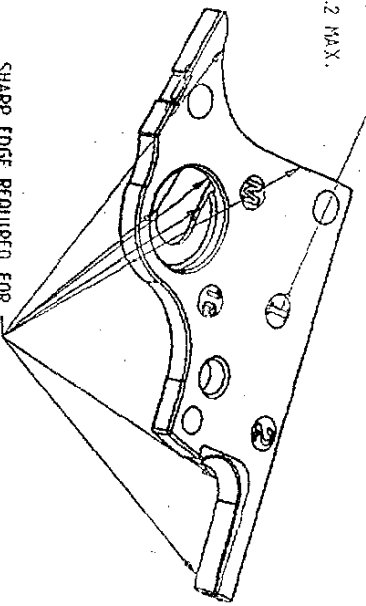

SHARP EDGE REQUIRED FOR
EASY MANUFACTURING

GATE MARK DEPRESSION
0.2 MAX/PROTRUSION NOT
ABOVE THE SURFACE "A"

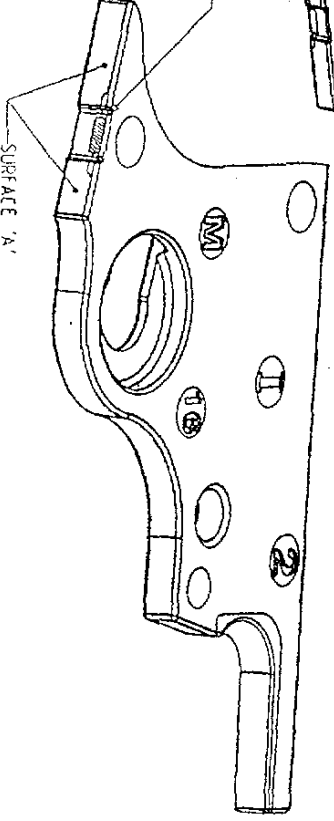

SURFACE "A"

NOTES:-
VOLUME OF THE PART = 0.635 cc
MINIMUM WALL THICKNESS = 0.654mm

EJECTOR

(THROUGH MIM ROUTE)

DRG. REF. NO. - D.S.CAT 1005-003156

DRG. NO. - REI.SK 10121

A 6 5 4 3 2 1



0.02 LAND REQUIRED ON THESE SURFACE TO AVOID PARTING LINE MISMATCH (WILL BE WITHIN THE TOLERANCE SPECIFICATION)

1° DRAFT FOR EASY MOLD RELEASE

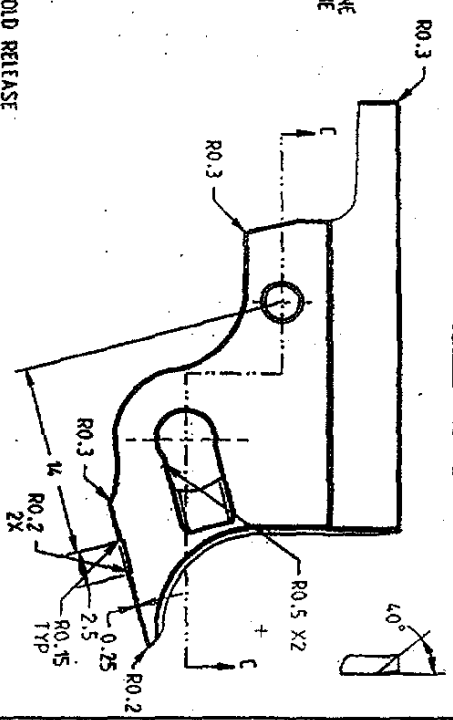

SLOT FOR GATE

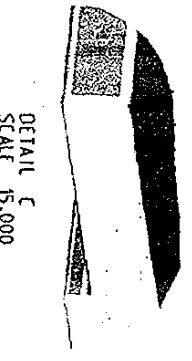
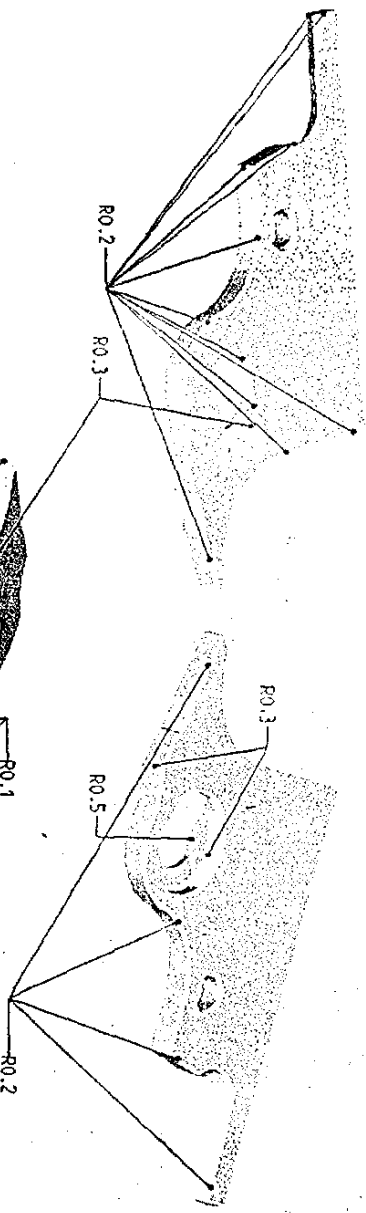

DETAIL C
SCALE 15,000

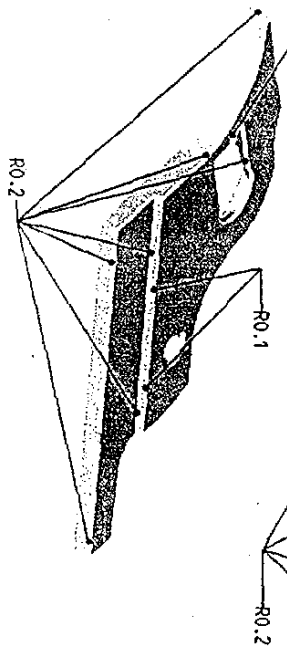

DETAIL A
SCALE 8,000

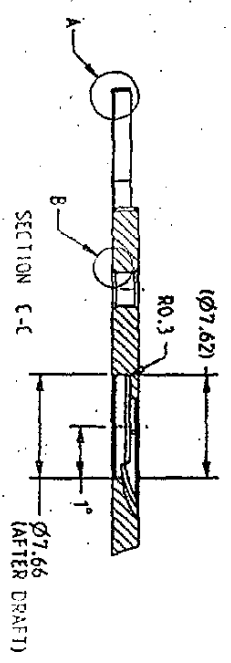

SECTION C-C

0.02 MISMATCH LAND

DETAIL B
SCALE 8,000

EJECTOR

(THROUGH MIM ROUTE)

DRG. REF. NO. - D.S.CAT 1005-003156

DRG. NO. - RFLSK 10121