

**TO BE MANUFACTURED THROUGH FORGING & MACHINING**

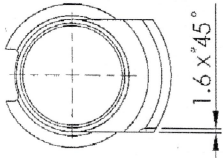

20A5(+.250, -0) T/2 0.1 (M) B (M)

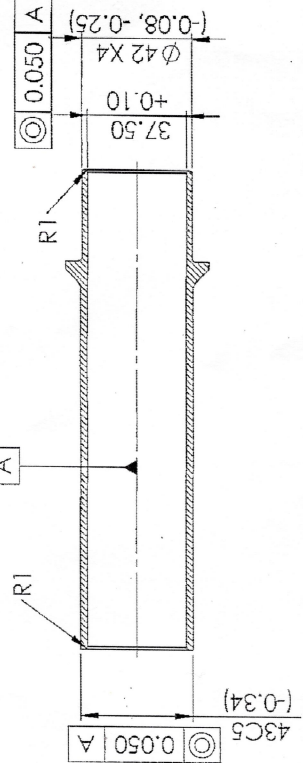
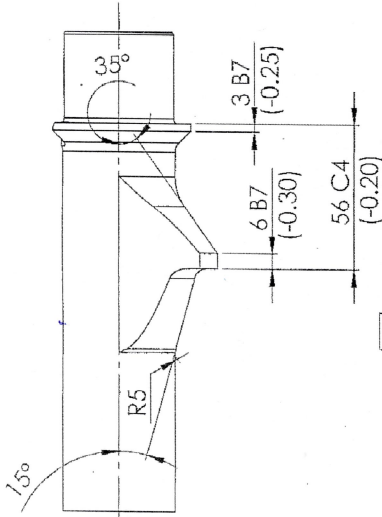
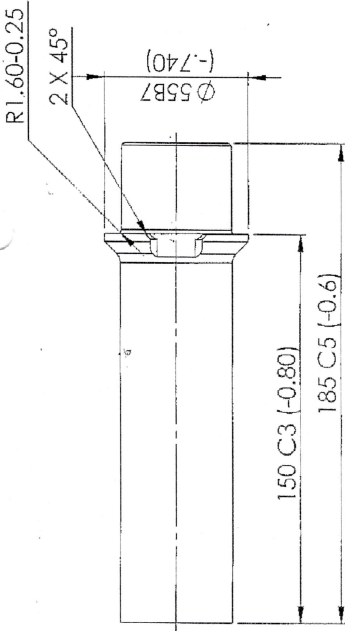
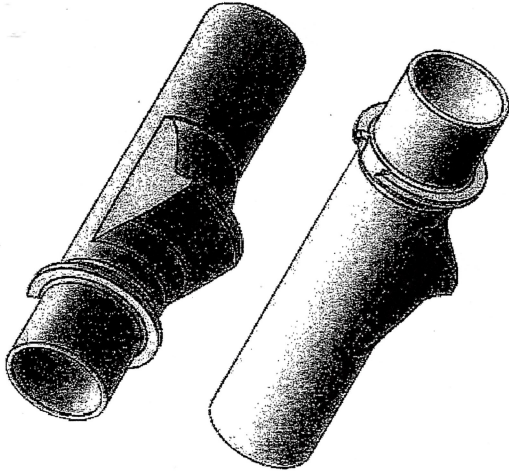
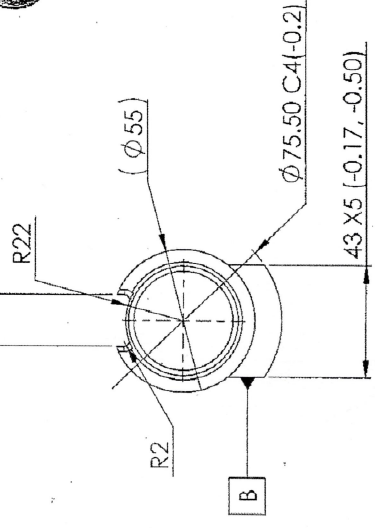

UN CONTROLLED COPY  
 CERTIFIED CORRECT COPY OF APPROVED  
 DRAWINGS AT THIS DATE: 21/12/2023  
 DESIGN & DRAWING OFFICE  
 ORDNANCE FACTORY, TIRUCHIRAPPALI - 620 016.

MATERIAL : STEEL 30 X H2M Ø A, OCT 3-98-80  
 ALT. MATRL : STEEL GRADE 826 M31, CONDITION 'Z', S & P CONTENT 0.025% EACH MAX  
 TO BS:970 PH 1-1983. A SEPARATE TEST SAMPLE IS TO BE HEAT TREATED  
 AND TESTED IN 'Z' CONDITION.

REF: FORGING DRAWING No. 64C 2037 200E3

SAMPLE MUST BE SUBMITTED AND GET APPROVED  
 BEFORE BULK PRODUCTION / SUPPLY

Material:		DWG Details		SUB: PRE-MACHINED BLANK	
Scale	Angle	Drawn	Checked	Sign	Date
Alt. Material:		FOR: BARREL CATCH C-2037			
Hardness:		PROJ.: 30mm CANNON			
Finish:		Design Ref			
Unilateral dimensions IS:2102 Medium		DWG. No.:		TEND 2726	
AMENDMENTS		Div. Officer Prod.		A3	
SIG. & Df		Div. Officer QC		QPG -	
		Div. Officer DDG		Wt. 643.24 gm	
		APPROVED ON: 28/11/2023		SHEET: 1 OF 1	

HEAT TREATMENT AND POST HT OPERATIONS WILL BE  
 DONE AT OFI.

HOS/PS6

