

PROVISIONAL

PILOT SAMPLE TO BE GET APPROVED BEFORE BULK SUPPLY.

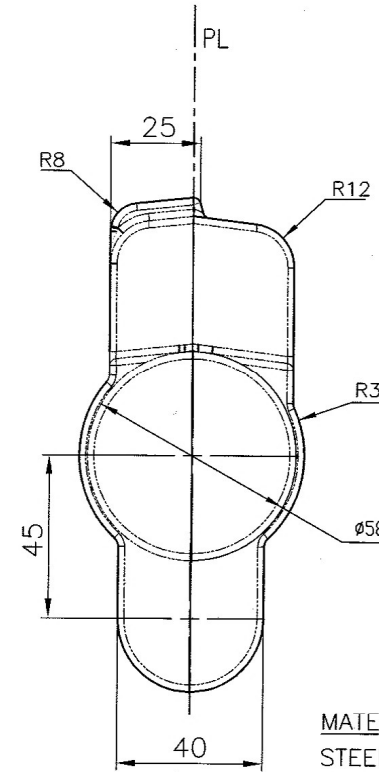
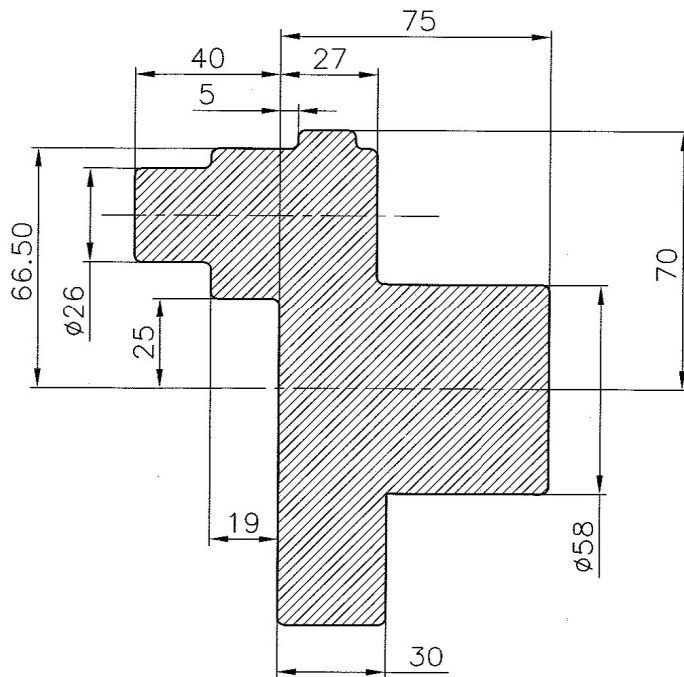
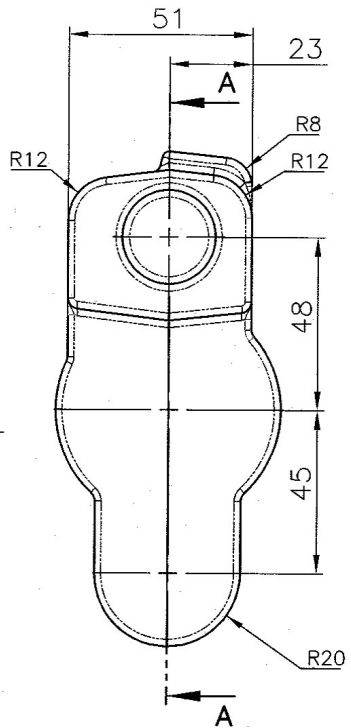
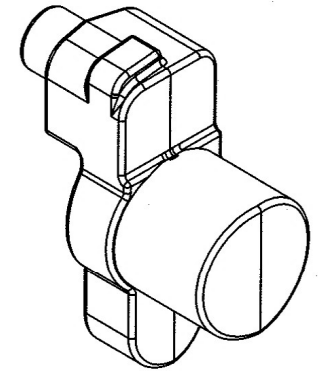

- NOTE:**
1. DRAFT ANGLE - 7°
 2. NON SPECIFIED RADII - 2mm
 3. HEAT TREATMENT:- NORMALIZING WITH HIGH TEMPERING
 4. THE REMAINDER OF THE BURR ON THE JOINT SHOULD NOT EXCEED 0.9mm
 5. END BURR SHOULD NOT EXCEED 5mm
 6. FORGING CORRESPONDS TO 2ND GROUP OF ACCURACY C2, M1 GOST 7505 - 74
 7. THE OTHER REQUIREMENTS AS PER GOST 8479 - 70 GROUP. 2
 8. FORGINGS SHALL CONFIRM TO AS PER IS: 3469 - 1974
 9. FORGINGS SHOULD BE SUPPLIED IN SHOT BLAST CONDITION.
 9. FORGINGS SHOULD BE FREE FROM DEFECTS SUCH AS UNFILLINGS LIKE DEEP PIT MARK, LAPS, CRACKS, DENTS SCALE AND ANY OTHER FORGING DEFECTS.

CERTIFIED CORRECT COPY OF APPROVED DRAWINGS AT THIS DATE.....
 17.11.2020
 Design & Drawing Office
 Ordnance Factory,
 Tiruchirappalli-620016
 UN CONTROLLED COPY

MATERIAL:-
 STEEL - 35XH2M0A-W-OCT3-98-80 (OR)
 STEEL - BS:970 Pt.1 1983 Gr.826 M40 (OR)
 STEEL - BS:970 Pt.3 1991 Gr.709 M40 (OR) En-19

HOS/PS-6

AMENDMENTS	SIG. & DATE		SIGNATURE & DATE.	SUB: FRONT FRAME FORGING	SCALE NTS
		TRACED		FOR: FRONT FRAME	QPG 1
		DRAWN	<i>[Signature]</i>	OF: 40mm MGL	Weight 2.429Kg
		CHECKED	<i>[Signature]</i>	DES.REF.NO. 30P 1104	SHEETS: 1
		OIC/D&DO	<i>[Signature]</i>	DRG. No.: 30C 1104 001 A3	SHEET No.: 1
		OFFICER/PRODN.			ORDNANCE FACTORY TIRUCHIRAPPALLI-16.
		DIV.OFFICER/D&DO			
		APPROVED ON 20/09/2018			