

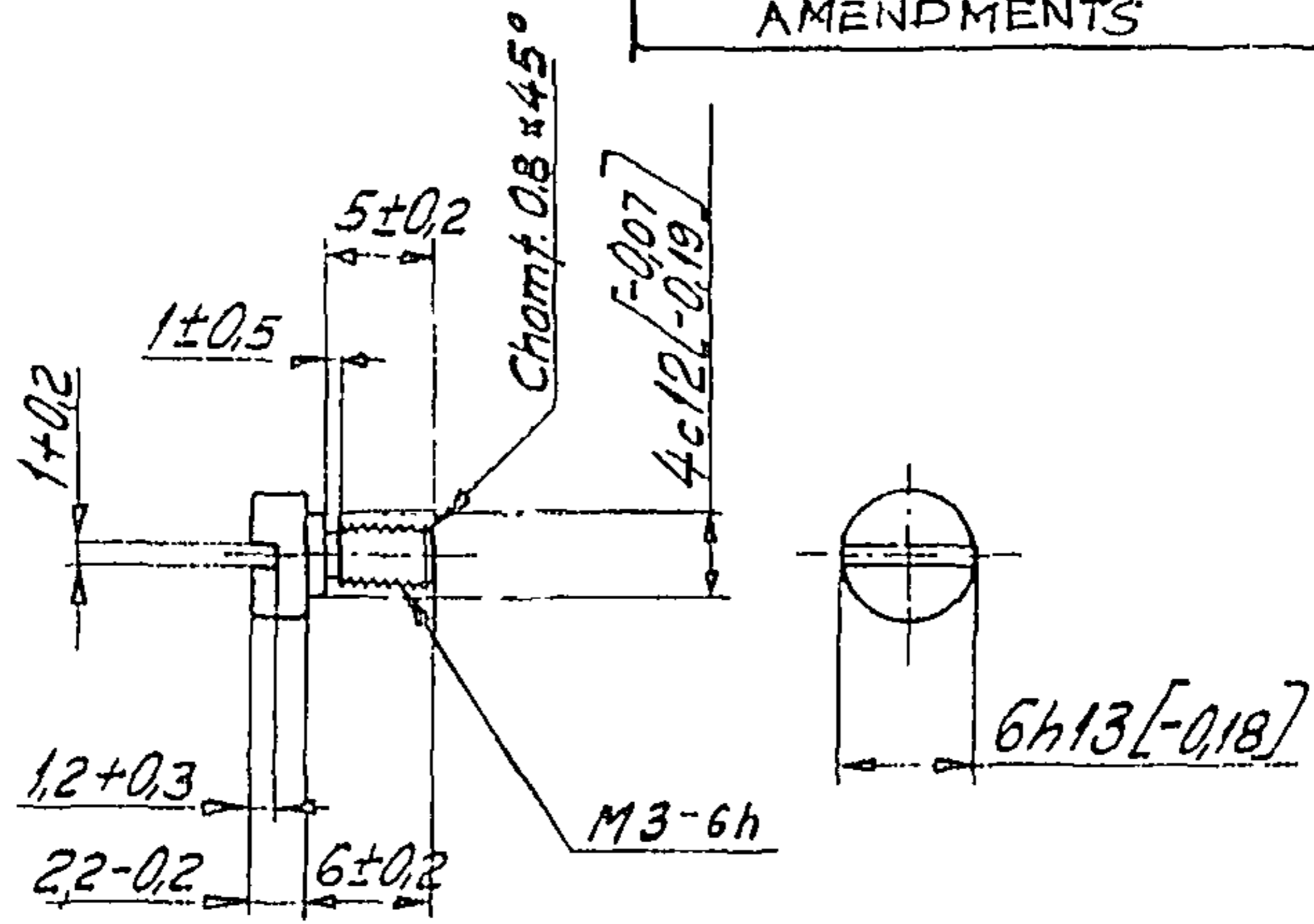

Ritningsändring - G H J K  
 Produktförändring F - - - -

(D)



ca) D.C.: - 2750-I (P):-			
DRG. No. AMENDED.			6.12.11
D.C.: - 2423-I (P)			18.7.07
DRG. PROV. SEALED			
AMENDMENTS	CHD	SIG.	DATE



  
 Scale 1:1

D.C.: - 2423-I (P), 2750-I (P)  
 DRG. VETTER BY QMI-4

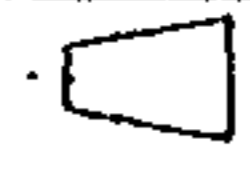
ANTAL PRODUKT  
 MATERIALKVALITÉ *Steel 551914 alt. EN 10087-1.0721*  
 VARMEBEHANDLING *Hardened: Surface hardness min 700 HV1. Hardness depth DC max 0,2*  
 YTBEKÄFFENHET: —  
 YTBEHANDLING: *Manganese phosphated and oiled to Gf 1.003.064*  
 GRADNING: ENL. FFV 66  
 LAGESMATT: ENL. FFV 213  
 MARKNING: —  
 TEKN BESTÄMMELSER *See above*

Ritad	Grans	Kop.	Stals	Kassa	Ypplösningsmetad	Skala
<i>KL</i>		<i>OL</i>	<i>LS</i>		 	<i>2:1</i>
Datum	Stand up	Kop gr	Stals		Europusk	Essätter

PRODUKT *Acc.f. 84 mm RCLM2 Telescope Sight 230141*  
 NAMN *Screw, short, housing*

FORSVARETS FABRIKSVVERK  
 CARL GUSTAFS STADS GEVÄRSFAKTORI

*CQA(1)-792/37*