

PART No. 2A42.01.002

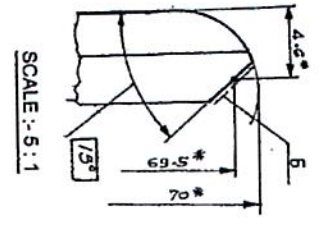
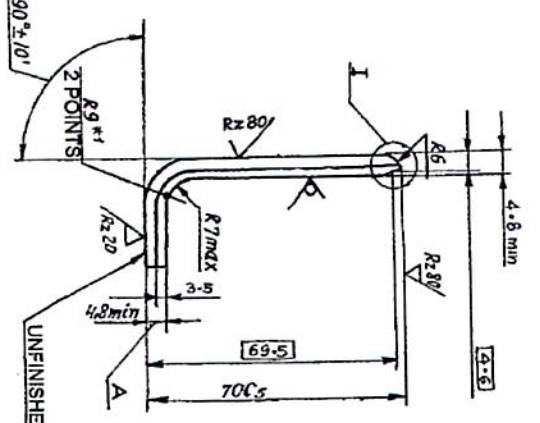
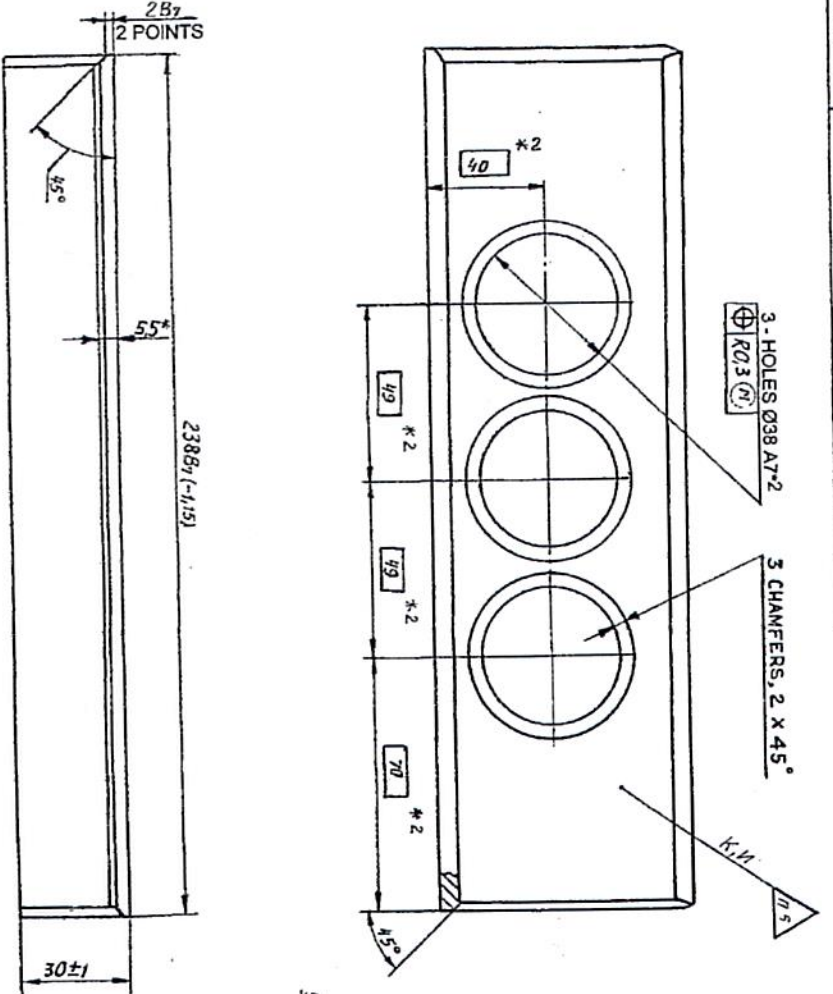

INDIGENOUS MATL:-  
 STEEL SdA 203M40'W' COND.  
 TO B 51970 Pkt-83

UN CONTROLLED COPY  
 CERTIFIED CORRECT COPY OF APPROVED  
 DRAWINGS AT THIS DATE: 11/11/23  
 DESIGN & DRAWING OFFICE,  
 APPROVED: [Signature] 11/11/23

- HRC var 34 to 40.5. Test for hardness using a blank sample
  - \* The size is given for reference
  - Blunt edges to R ≈ 0.6 mm.
  - Coating: accelerated electroless phosphating with chromate treatment.
  - Stamp.
  - \* The size is provided by tool
  - CHECK THE DIMENSIONS BEFORE ENSURING THE DIMENSION A
  - TOLERANCE ALONG CONTOUR B IS 0.5mm CHANGE OF TOLERANCE ALONG CONTOUR C TO 0.8mm IS PERMISSIBLE IN ZONE OF HOLES ON A TOTAL LENGTH HGT IN EXCESS OF 150 mm
- MATERIAL: Sheet TH-0-5.5, TOOR 19903-74  
 JOIXVA-3-a, TOOR 11259-76

C 1002

DRAWN:-		CHKD:-		ASSEMBLING:-	
SCANNED-SMB		CHKD- GSN		DATE:-	
AUTHORITY ZONE		AHP		SCALE: 1:1	
DATE 13-7-06		DO FOR QA(W)		EBO mass- 071	
AMENDMENTS		DO		DESIGN No.	
SCANNED & PRINTED WITHOUT CHANGE		DO		PART No.	
18942-W & 18945-W DT. 13-01-04		DO		2A42.01.0	
PREV DC No:- 18407-W, 18903-W, 18976-W, 17187-W, 17765-W, 18174-W, 18291-W, 18412-W		DO		DS CAT No.	
18942-W & 18945-W DT. 13-01-04		DO		2A42.01.0	
DWG SEALED:- 18174-W DT. 22-09-96		DO		DS CAT No.	
		DO		2A42.01.0	

INSERT ३११८