

REDRAWN AS PER ORIGINAL RUSSIAN DRAWING.

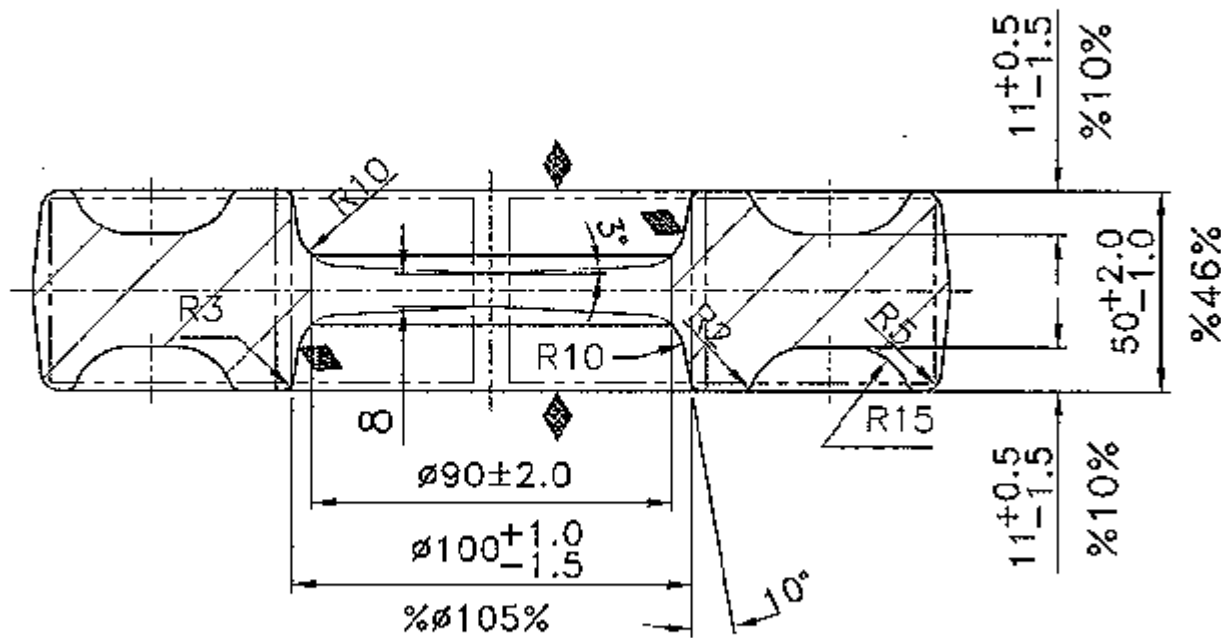
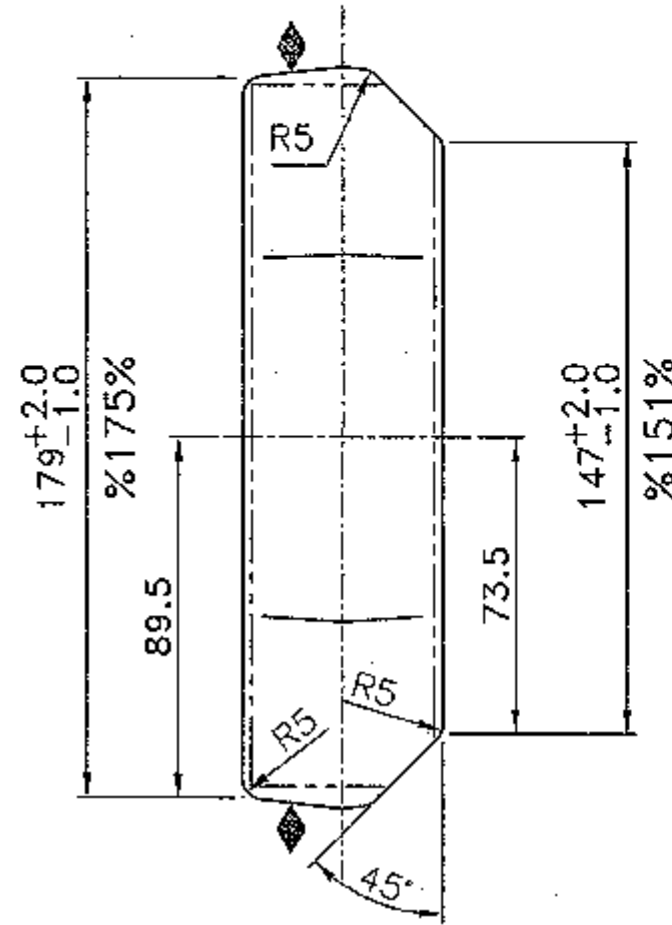
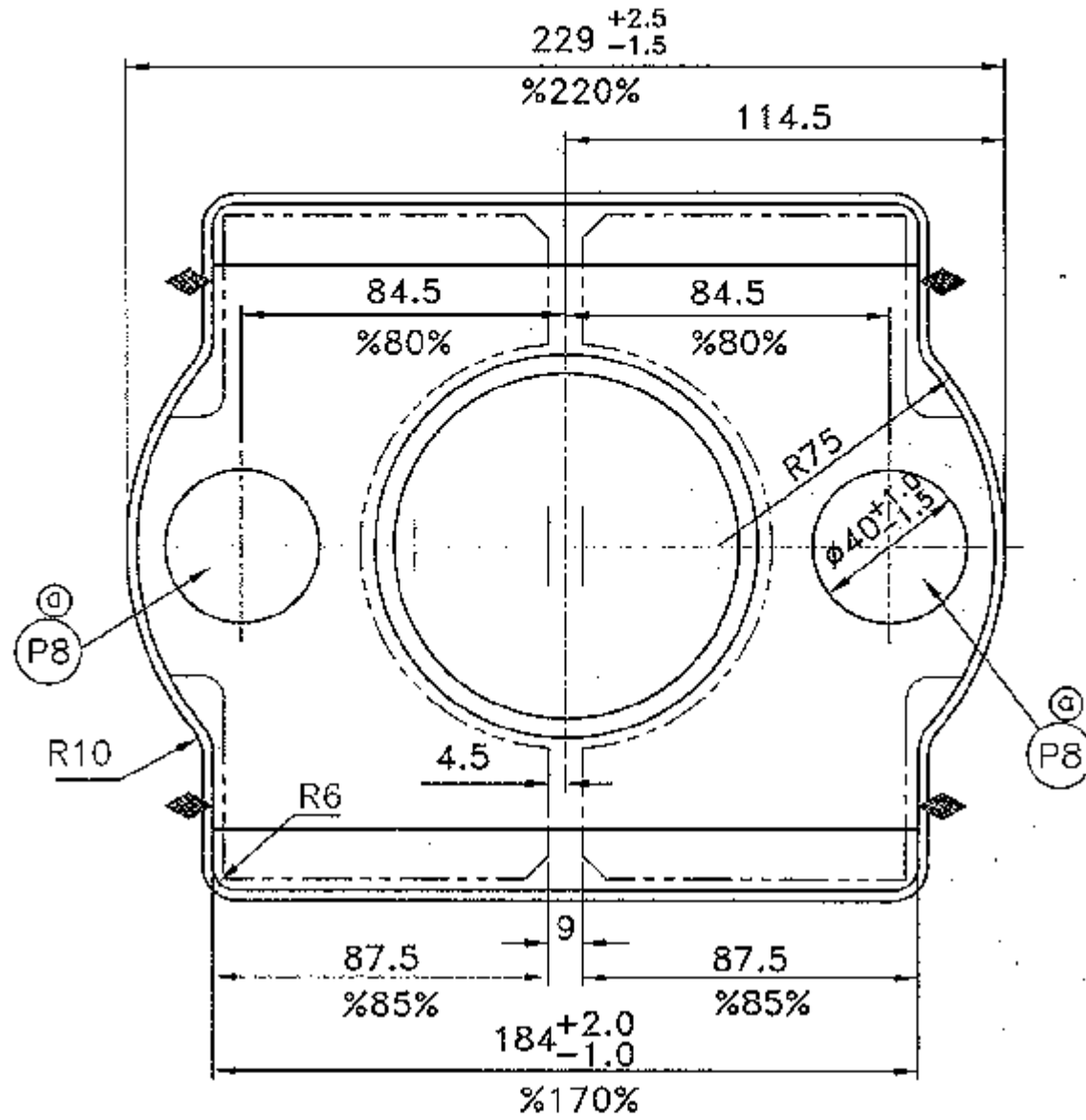

NOTE:

1. UNSPECIFIED DRAFTS ARE TO BE 6° MAX.
2. MISMATCH OF DIE AXES SHOULD NOT EXCEED 1.0 mm
3. RESIDUAL FIN ALONG THE PARTING PLANE SHOULD NOT EXCEED 1.0mm PER SIDE AND THE PRESSED-IN FIN IN THE HOLE SHOULD NOT BE MORE THAN 3.0 mm
4. LOCAL PIT MARKS ON THE SURFACES TO BE MACHINED SHOULD NOT EXCEED 0.5 OF THE MACHINING ALLOWANCE AND ON THE SURFACES NOT TO BE MACHINED, THEY SHOULD NOT EXCEED 1.0 mm
5. BUCKLING AND CURVATURE SHOULD NOT EXCEED 0.5mm.
6. ECCENTRICITY OF THE PIERCED HOLE SHOULD NOT EXCEED 1.5 mm
7. DIMENSIONS WITH UNSPECIFIED TOLERANCES ARE PROVIDED FOR CONSTRUCTION
8. ALLOY GRADE Д1 IS TO BE MARKED USING TYPE 1 TO 5
9. \blacklozenge --- DATUM FOR MACHINING

SIGN		DATE	DRG. NO. 3301-187A		
DRAWN	<i>[Signature]</i>	24/11/11	CAP (FORGING)		
CHECK	<i>[Signature]</i>	24/10/11			
APPR.					
AUTHD.					
			SHEET	MASS	SCALE
			1		N.T.S
			ENGINE FACTORY AVADI		
			MATERIAL: DURALUMIN Д1 GOST 4784-74		