

(C)	17068-W DT. 7.5.91		
(D)	17901-W DT. 12.2.94		

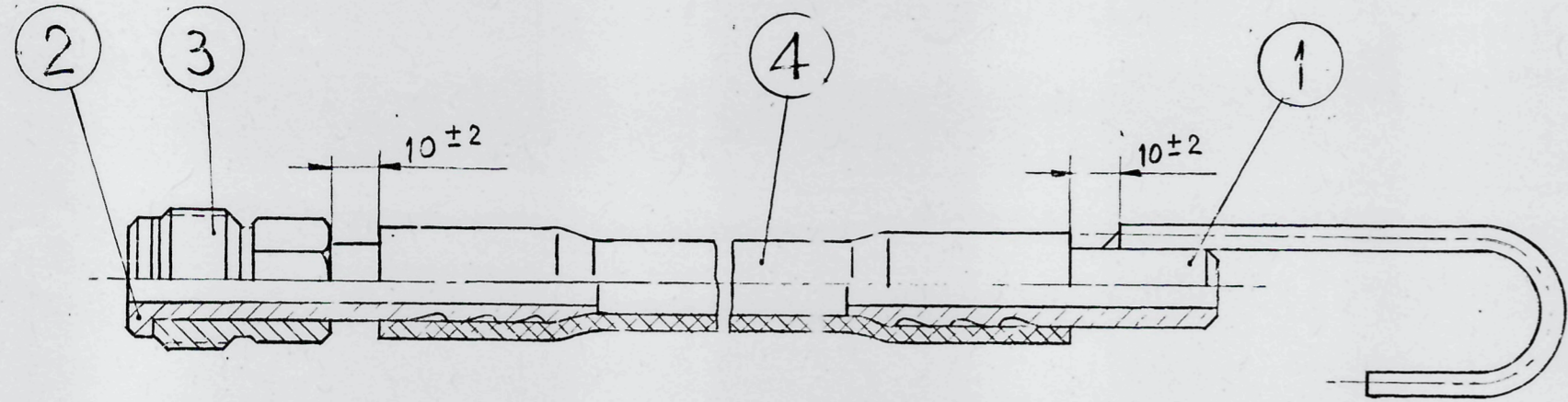

ELECTRODES:-
ASSEMBLY 1. UNIVERS OF ADWANI OEPKON.
 SCALE:- 1:1 2. INDOHERME OF D&H SECHRON.

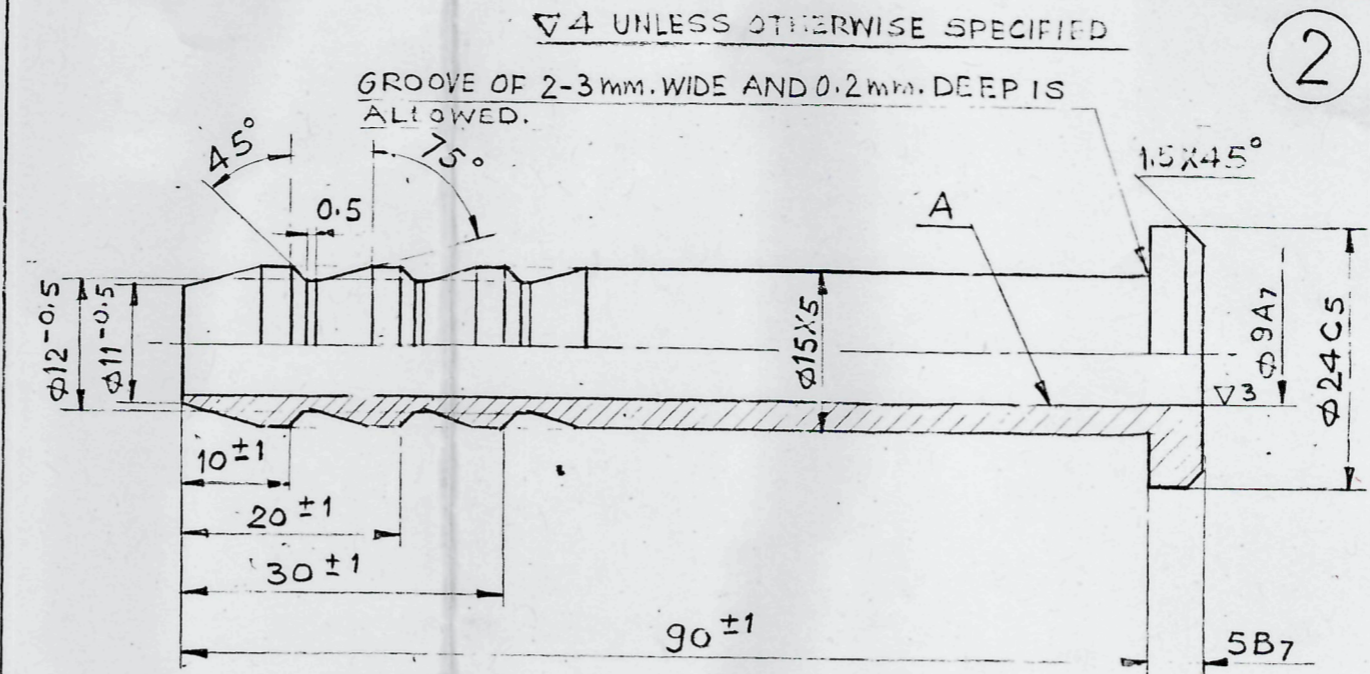

- HEAT TREATMENT: GR. 1-K20 OST 3-1686-80.
- COATING: CHEMICAL PHOSPHATING, CHROMATIZING ADHESIVE Bφ-2 OR 5φ-4 WITH NIGROSINE, BLACK (2).
- SURFACE A MAY BE FREE OF ADHESIVE.

MATL:- STEEL 20 GOST 1050-74.
 ALT. MATL:- STEEL TO IS: 2073-70, Gd. C-20 OR 080M-15 OR 070 M20 TO BS: 970 Pt.1; 1983 IN NORMALISED CONDITION.

NIPPLE 2A26-42-17/DS.CAT.NO. 1015-004181
 SCALE:- 2:1

(B)	17828-W DT. 14-12-93		
(A)	16313-W DT. 22.4.85		
INDEX	AMENDMENTS	SIGN.	DATE

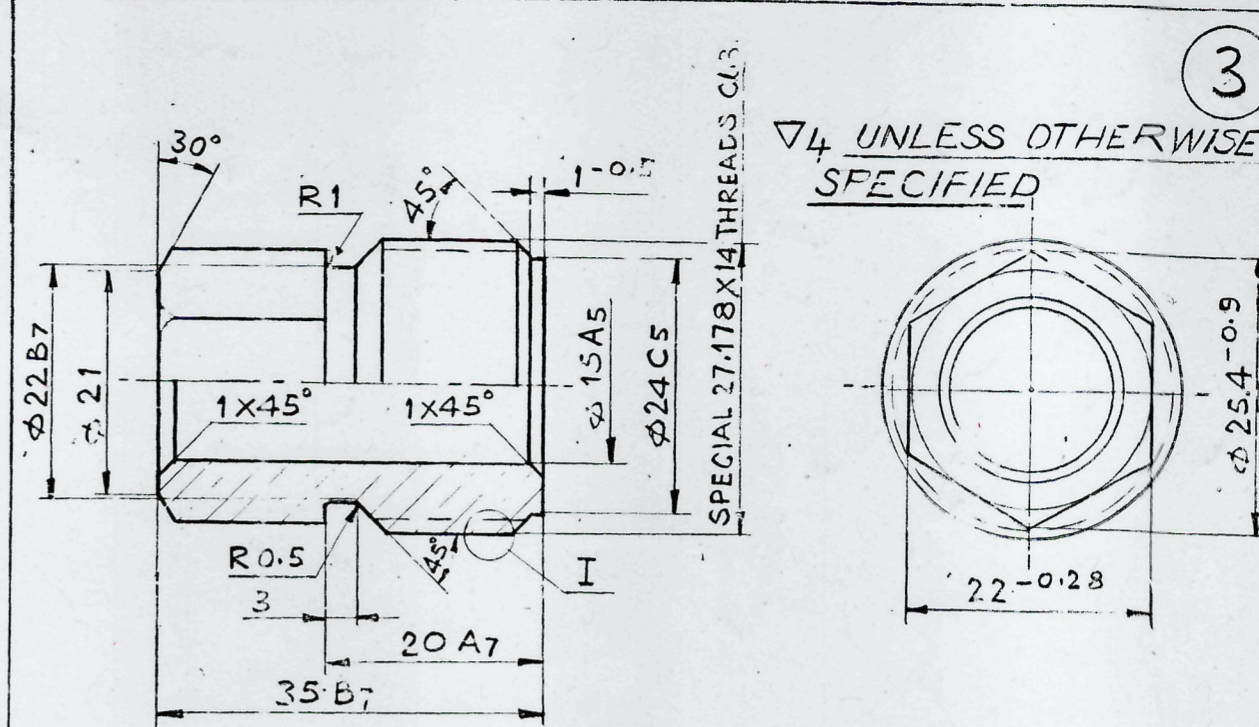

MATL:- STEEL 40 GOST 1050-74.

- HEAT TREATMENT; GR. 1-K30 OST 3-1686-80.
- COATING - Cd. 9, CHROMATIZING.

ALT. MATL:- STEEL TO IS: 5517-78, 40C-08 OR 080M40 TO BS: 970 Pt.1, 1983 IN NORMALISED CONDITION.

NUT - 2A26-42-18
 SCALE 2:1 DS.CAT.NO. 5310-242296

(D)	0055-AVA DT. 11.02.10		
(C)	17850-W DT. 15-1-94		
(B)	17828-W DT. 14-12-93		
(A)	16313-W DT. 22.4.85		
INDEX	AMENDMENTS	SIGN.	DATE

(B)	17088-W DT. 4.7.91		
(A)	16313-W DT. 22.4.85		
INDEX	AMENDMENTS	SIGN.	DATE

REPRODUCED FROM ORIGINAL NO. 1

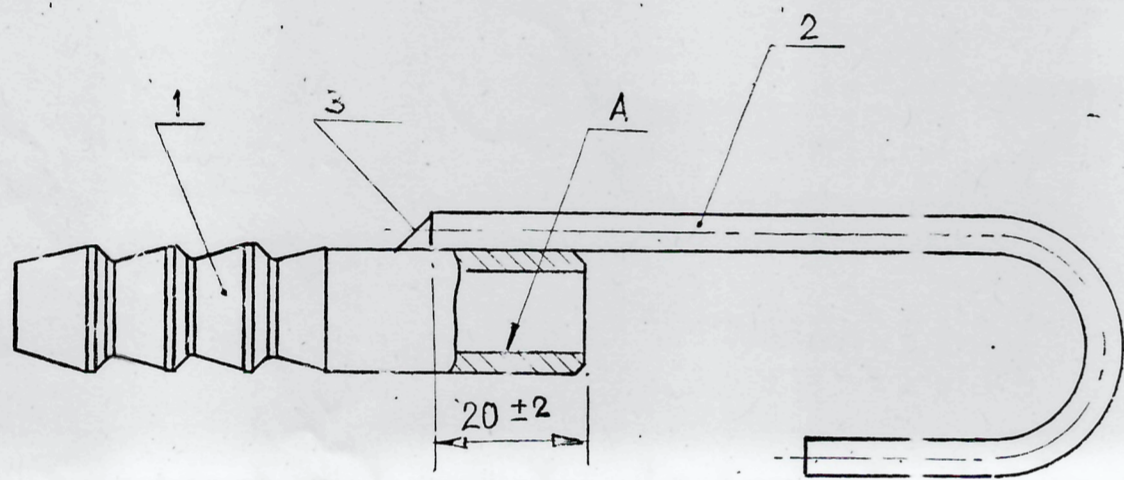

- COATING - CHEMICAL PHOSPHATING, CHROMATIZING ADHESIVE Bφ-2 OR Bφ-4 GOST 12172-74 WITH ALCOHOL-SOLUBLE NIGROSINE A, BLACK GOST 9307-78 (2).

- ELECTRODE 350A GOST 9467-75.
- SURFACE A MAY BE FREE OF ADHESIVE.
- REQUIREMENTS TO THE QUALITY OF THE WELD ARE ACC. TO THE 3rd CATEGORY, OST 3-4001-77.

HOOK ASSEMBLY RE. DRG. NO. 2A26-42-7CB/ DS. CAT. NO. 1015-004181
 SCALE:- 1:1

(B)	17088-W DT. 4.7.91		
(A)	17068-W DT. 7.5.91		
INDEX	AMENDMENTS	SIGN.	DATE

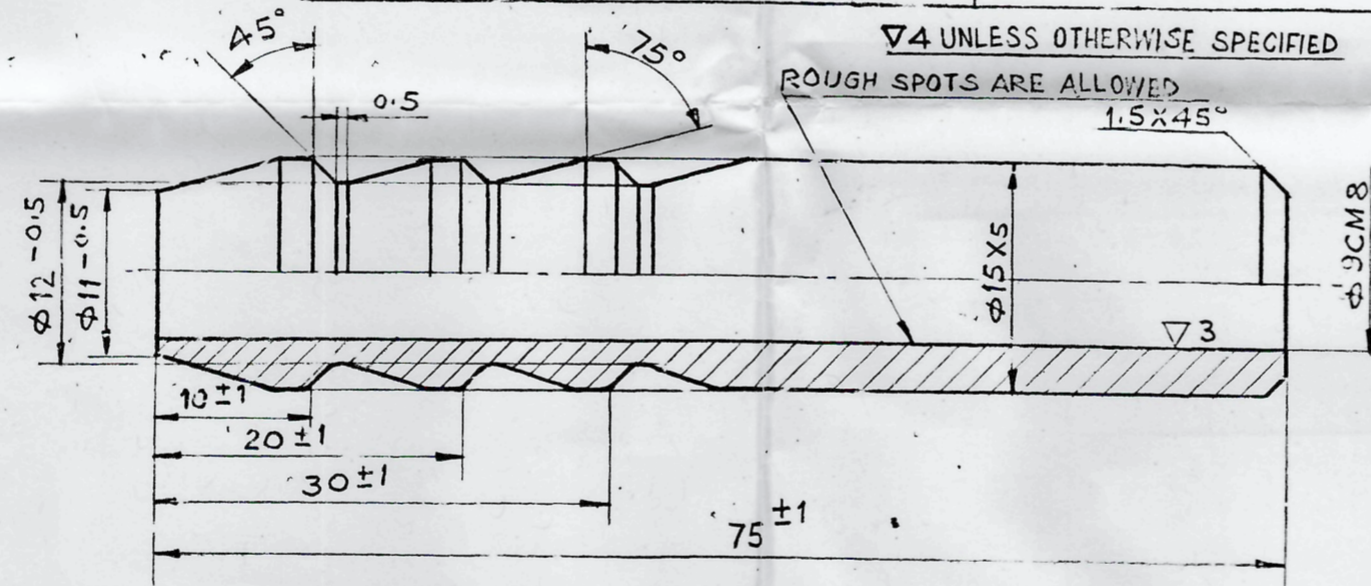

- INTERNAL CORNERS ARE R≈0.4 mm.
- SHARP EDGES ARE TO BE BLUNTED TO R≈0.6 mm.

MATL:- STEEL B20 GOST 8733-74, DS. CAT. NO. 4730-078239
 ALT. MATL:- CARBON STEEL BAR IS: 2073-70 Gd. C20 OR BS: 970 Pt.1, 1983 IN NORMALISED (BY MACHINING)

NIPPLE SCALE:- 2:1

(C)	17850-W DT. 15-1-94		
(B)	17088-W DT. 4.7.91		
(A)	16313-W DT. 22.4.85		
INDEX	AMENDMENTS	SIGN.	DATE

- NOTE:-**
- THIS DOCUMENT IS THE PROPERTY OF THE GOVT OF INDIA M. OF D. AND IS ISSUED FOR THE PURPOSE OF DEVELOPING/MANUFACTURING STORES REQUIRED FOR DEFENCE USE.
 - IT MUST NOT BE REPRODUCED/DISCLOSED TO ANY THIRD PARTY OR USED FOR ANY CIVIL PURPOSE.
 - IT MUST BE RETURNED TO THE ISSUING AUTHORITY WHEN THE PURPOSE OF ITS ISSUE HAS BEEN SERVED.
 - PILOT SAMPLE TO BE APPROVED BEFORE BULK SUPPLY.

(G)	GCF/SC/281/DRG/VETT/UC	28.6.00	
(F)	GCF/SC/281/DRG/VETT/UC	18.9.98	
(E)	GCF/SC/281/DRG/VETT/UC	7.1.97	
(D)	GCF/SC/281/DRG/VETT/UC	06.12.16	
(C)	GCF/SC/281/DRG/VETT/UC	27.2.15	
(B)	GCF/SC/281/DRG/VETT/UC	20.5.13	
(A)	GCF/SC/281/DRG/VETT/UC	5.8.12	
(A)	GCF/SC/281/DRG/VETT/UC	13.5.11	
(A)	GCF/SC/281/DRG/VETT/UC	27.2.99	

0055-AVA DT. 11.02.10

ELECTRODES:-		UNIVERS OF ADWANI OEPKON.	
4.	TUBE 3M12X3.0-4.0 GOST 5496-78 L=1500 RUBBER TUBE TO IS: 637-1994	1	
3.	NUT	1	5310-242296
2.	NIPPLE	1	2A26-42-17 DS. CAT. NO. 1015-004181
1.	HOOK ASSEMBLY	1	2A26-42-7CB DS. CAT. NO. 1015-004181
INDEX	AMENDMENTS	SIGN.	DATE

DRAIN PIPE ASSEMBLY WITH DETAILS

UNIVERS OF ADWANI OEPKON. INDOHERME OF D&H SECHRON.

13.5.11

1990

DRG No. GCF.TM-383 (G)

GUN CARRIAGE FACTORY, JABALPUR

MATL:- WIRE 50-C GOST 3282-74.
 ALT. MATL:- WIRE TO IS: 2073-70 Gd. C-20 OR BS: 970 Pt.1, 1983 BRIGHT DRAWN HAND.

HOOK
 SCALE:- 1:1

(C)	17850-W DT. 15-1-94		
(B)	17828-W DT. 14-12-93		
(A)	16313-W DT. 22.4.85		
INDEX	AMENDMENTS	SIGN.	DATE