

5320

DIMNS ARE IN mm.

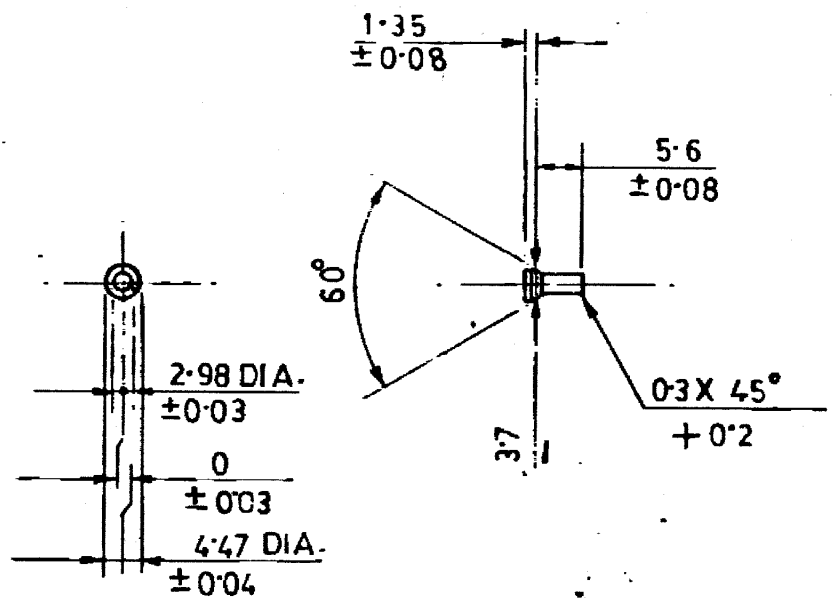

Hos/mes
21/06/22
si

SURFACE FINISH :-
 AS PER IS:3073, WHERE NOT SPECIFIED SHOULD BE W.

HEAT TREATMENT :
 CONTINGENTLY ANNEALED AT 650°C PRIOR TO RIVETING.

CERTIFIED COPY OF THE
 STORE DRG / GAUGE DRG / Sch /
 SPEC / PROJE. SHE.
Abhikari
 DATE: 15-02-21 JTC(D)

04.02.21	27286-SA	HEAT TREATMENT AMENDED		<i>Abhikari</i>	<i>ITC</i>
16.01.17	27014-SA	MATERIAL AMENDED.		<i>M...</i>	<i>ITC</i>
27.05.2002.	25374-SA	RECORD OF RECEIPT CANCELLED AND DRG. SEALED AFRESH		<i>CD</i>	<i>OPY/DAC</i>
17-1-2000	24613-SA	PROFORMA CHANGED.NEG.RE-TRACED AND DRG. RE-SEALED AS A RECORD OF RECEIPT.		<i>...</i>	<i>...</i>
		PREVIOUS D.C.NOS.15508-SA, 16534-SA, 19644-SA, 21693-SA, 22334-SA & 23382-SA.			
DATE	AUTHY.	BRIEF RECORD	ZONE	I/C; D.O.	G.O.
SEALED :- D.C.NO. 25374-SA DT. 27.05.2002.			SIGN.		

DRN.	CHD.	TRD. <i>...</i>	COMP. <i>...</i>	AHSP. COA(SA), ICHAPUR	
SCALE = 1:1		EST. MASS.		ASSY. 1005-007718, 1005-007717	
DT 17/1/2000 <i>Anca.</i>		APPROVED. DT			
I/C; D.O.		NEG. RE-TRACED			
MATERIAL - MILD STEEL WIRE TO SPECN. IS: 1148-2009, MEDIUM TENSILE.				DGNR'S REF.	
HT/HARDNESS				PART No. 1025 X	
PROTECTIVE FINISH.				DRG No. A 1206	
NOMENCLATURE : RIVET GUIDE UPPER				D.S.CAT. No. 5320-000953	