

DRG.No. 3304-08-9 & 08-11
3304-08-9 & 08-11

ISSUE	DDO.REF.	AMENDMENT	SIGN	DATE

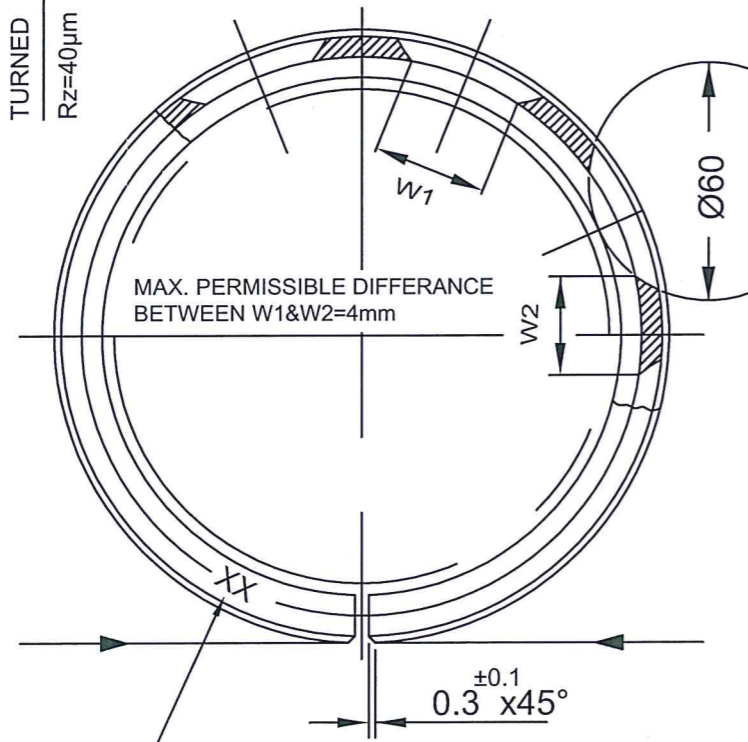
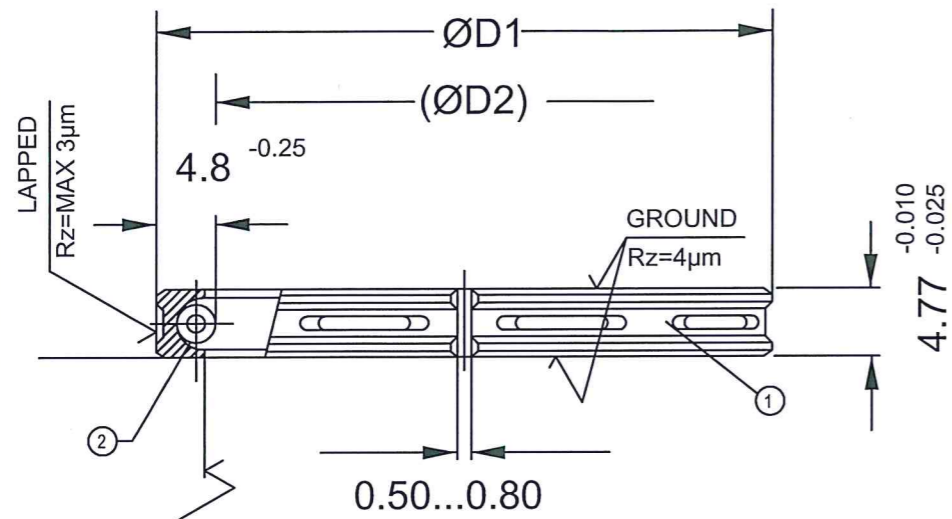

SIZE DETAILS

3	3304-08-9R2 & 08-11R2	R2	R2	150.2	140.6	466.0
2	3304-08-9R1 & 08-11R1	R1	R1	150.1	140.5	465.5
1	3304-08-9 & 08-11	STD	STD	150.0	140.4	465.5
SL	Drawing NO:-	SIZE	SIZE MARK	D1	D2	L1

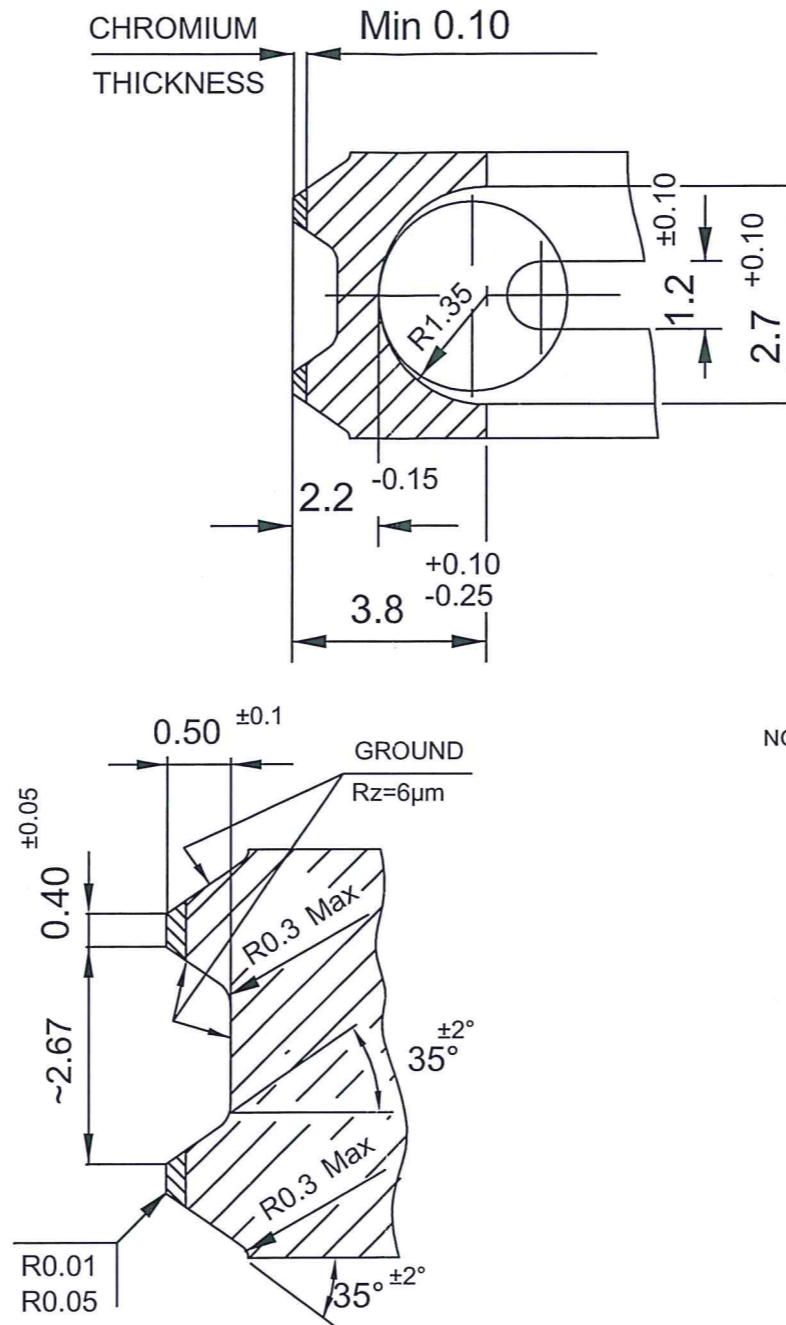

TANGENTIAL LOAD (WITH COILSPRING)	3600...5000gr
MANUFACTURING PROCESS	DOUBLE CAM TURNED
STAMP MARKING	REFER SKETCH
OUTSIDE EDGES	CROSS BEVELLED
INSIDE EDGES	SHARP & BURR FREE
NO OF SLOTS	12
SPRING GAP	180° TO RING GAP
MAX. PERMISSIBLE GROOVE ROOT DIA	139.4
SURFACE TREATMENT	-

NOTE:

1. UNSPECIFIED DIMENSION AND TEST OF QUALITY CHARACTERISTICS SUBJECT TO ISO 6621-1 TO 6621-5 & 6626
2. PILOT SAMPLE SHOULD BE APPROVED, BEFORE BULK PRODUCTION.

2	COIL SPRING	1	IS4454, PART I, Gr 3	2.6/0.90x1.7xL1		
1	RING	1	Std(K1)	D1 X 4.77		
ITEM	DESCRIPTION	QTY	MATERIAL	SPECN	SIZE	REMARKS
	GEN.TOL.	COMPONENT NO.	OPN.NO.	M / C . NO.	SIGN.	DATE
	0 - 6 ± 0.1 6 - 30 ± 0.2 30 - 120 ± 0.3 120 - 400 ± 0.5 400 - 1000 ± 0.8 1000 - 2000 ± 1.2 2000 - 4000 ± 2	SB 3304-01-8 V46-6 ENGINE	ASSEMBLY		DRN.BY [Signature] CKD.BY [Signature] APPD.BY [Signature] AUTHD.BY [Signature]	13/12/17 13/12/17 13/12/17
	SCALE:- NTS	TITLE:- CHROMIUM PLATED CONFORMABLE OIL RING -TYPE GO 582C 150 /140.4 X 4.77			DRG.No. 3304-08-9 & 3304-08-11	
		ENGINE FACTORY, AVADI.			SHEET 1 OF 1 SHEETS ISSUE	

