

1	2	3	4	5	6	7	8
MIMZ-1 PH ON DRG				DATE		D.A.NO	
NO. QS/ISO-9000/DO/01				DATE		NATURE	
REV. NO. 00-DT. 09-06-2001						J.W.M.(D.O.)	

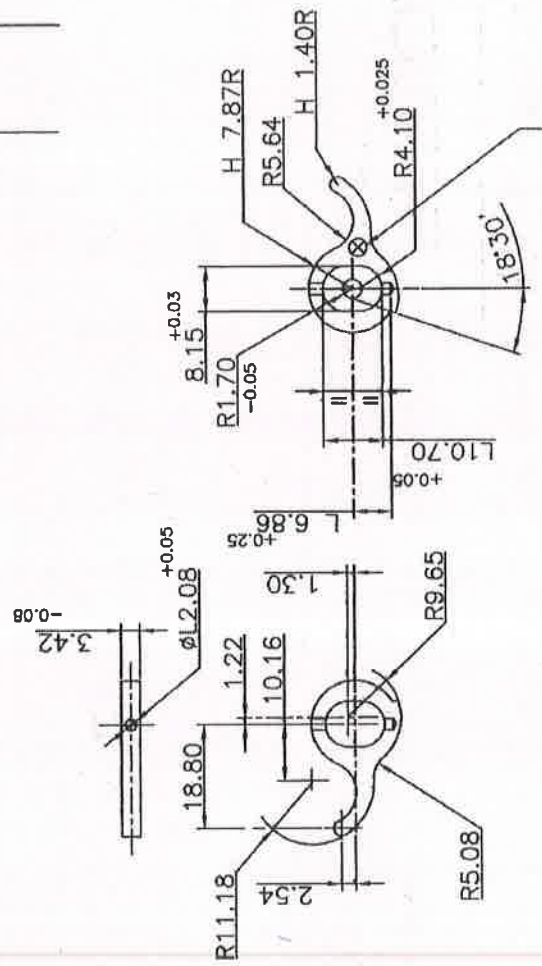

MANUFACTURER'S INITIAL, BATCH No. & YEAR OF MANUFACTURE TO BE MARKED ON THE SURFACE MARKED THUS '⊗'

**MATERIAL FOR MIM ROUTE**  
 ASTM MIM-4605 OR MPIF-4605  
 C : 0.4-0.6%  
 NI: 1.5-2.5%  
 MO: 0.2-0.5%  
 SI: 1.0% MAX  
 FE : BALANCE  
 SINTERED DENSITY : 7.5 MIN g/cm<sup>3</sup>

**HEAT TREATMENT:-**  
 HARDEND & TEMPERED:- 450 - 550 D.P.N.  
 PROTECTIVE FINISH:- PHOSPHATED TO SPECN/JSS-0465-01-1988  
 CLASS II (ACCELERATED) OIL FINISH

A TOLERANCE OF -0.05 IS ALLOWED ON ALL PROFILES

DIMENSIONS ARE IN mm.

REVOLVER 32(7.65mm)MK-1	DRAWN	TRACED	CHECKED
LEVER EXTRACTOR	<i>As per</i>		
	DATE	27.06.18	
	APPROVED	<i>Amurag 27/06/18</i>	
	DRG. NO.	J.W.M./D.O.	
	SCALE	PH 1-7 MIM	
	NTS	KANPUR	
		SHT. 1 OF 1	

ORIGINAL DATE OF APPROVAL:-20-4-74

ORIGINAL