

DRG. No. SP-56

DIMENSIONS ARE IN mm.
INFORMATION MARKED THUS 'T' TO BE MARKED ON
UNTOLERATED DIMENSIONS AS PER IS. 2102 (MEDIUM)

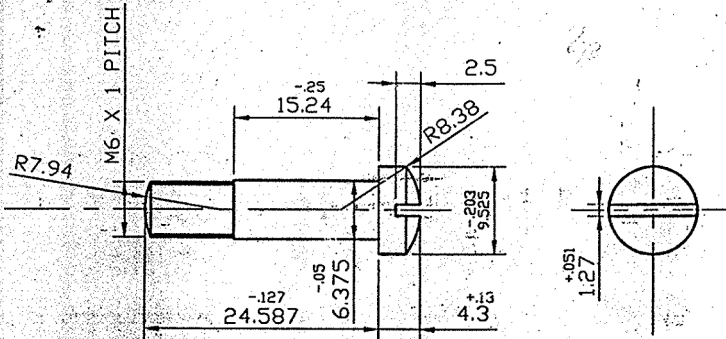

M 6 X 1 PITCH

NOTE :- HEAD OF SCREW TO BE POLISHED BEFORE HARDENING OR PHOSPHATING

MATERIAL :- STEEL BS 970 PT.1-1983 GR.045 M-10 (CASE HARDENING)

HARDNESS:- 300-400 H.V

PROTECTIVE FINISH :- PHOSPHATE TO SPECN. JSS 0465-01:1988 CLASS 1 OIL FINISH

PART NO.	DESCRIPTIONS	NO OFF	MATERIAL	TREATMENT	REMARKS															
	<table border="1"> <tr> <td></td> <td>SIGNATURE & DATE</td> </tr> <tr> <td>TRACED</td> <td></td> </tr> <tr> <td>DRAWN</td> <td><i>V. K. V. V.</i></td> </tr> <tr> <td>CHECKED</td> <td><i>V. K. V. V.</i></td> </tr> <tr> <td>VOIC/D&DO</td> <td><i>V. K. V. V.</i></td> </tr> <tr> <td>PRODN. OFFICER</td> <td></td> </tr> <tr> <td>DIV. OFFICER D&DO</td> <td></td> </tr> </table>		SIGNATURE & DATE	TRACED		DRAWN	<i>V. K. V. V.</i>	CHECKED	<i>V. K. V. V.</i>	VOIC/D&DO	<i>V. K. V. V.</i>	PRODN. OFFICER		DIV. OFFICER D&DO					SUB: SCREW FOR: GUARD TRIGGER FRONT OF: .315" SPORTING RIFLE DES. REF. NO: SP-56 DRG. NO: 29P.0056	SCALE 2:1 STORE DRG. NO. OPERATION NO.
	SIGNATURE & DATE																			
TRACED																				
DRAWN	<i>V. K. V. V.</i>																			
CHECKED	<i>V. K. V. V.</i>																			
VOIC/D&DO	<i>V. K. V. V.</i>																			
PRODN. OFFICER																				
DIV. OFFICER D&DO																				
AMENDMENTS	SIG. & DATE APPROVED ON:				ORDNANCE FACTORY TIRUCHIRAPALLI-16.	SHEETS: SHEET NO:														