

DRG. NO. 44P 03010

DIMENSIONS ARE IN mm.

UNTOLERATED DIMNS. AS PER IS : 2102 (MED)

MARK DRAWING No.

SHARP CORNERS TO BE BLUNT TO R0.2.

PROVISIONAL DRG.

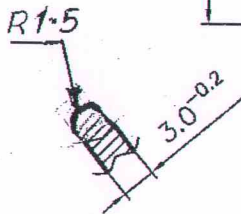
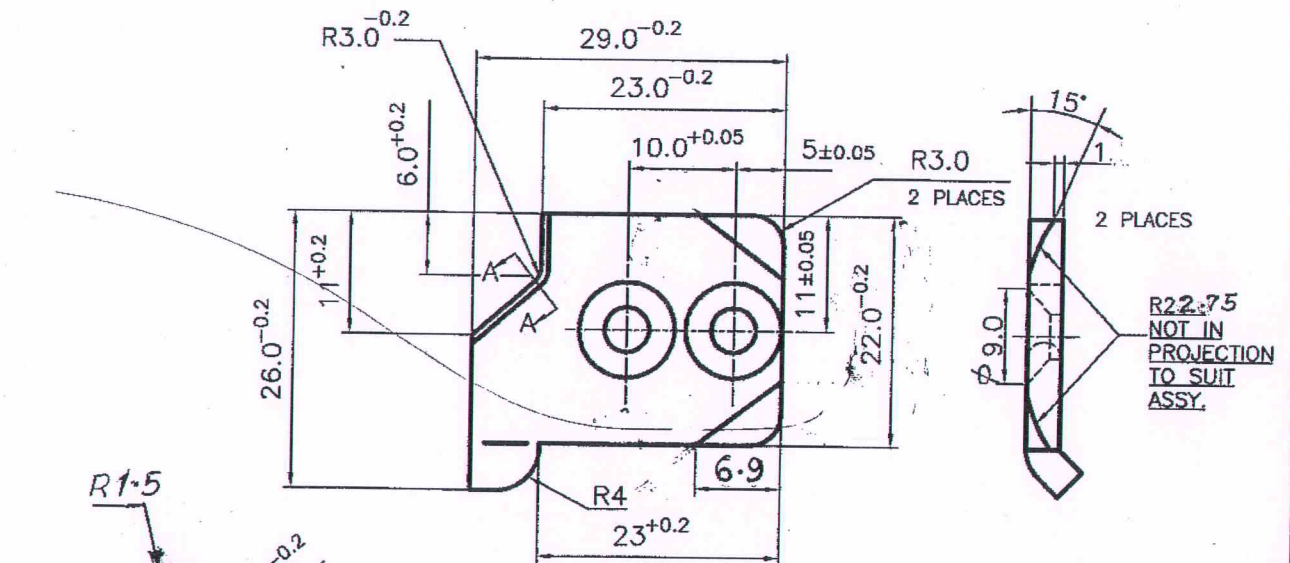

SECTION 'A-A'

UN CONTROLLED COPY
CERTIFIED CORRECT COPY OF APPROVED
DRAWINGS AT THIS DATE 18/5/22

DESIGN & DRAWING OFFICE,
ORDNANCE FACTORY, TIRUCHIRAPPALI - 620 016.

FINAL HARDNESS:
RC. 42-48

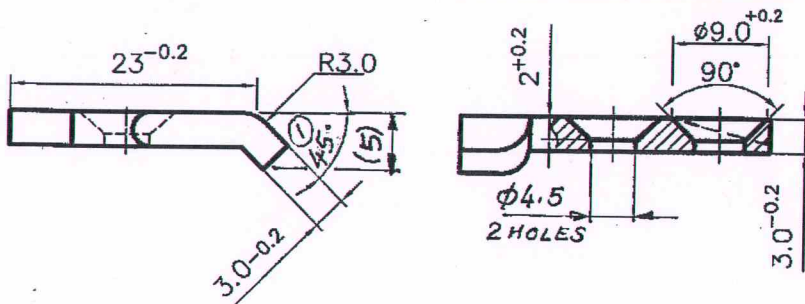

MATERIAL: 30X.H2MΦA, HARDNESS: 260-300 HB

ALT. MATL: BS.970 PT-1-1983 GR.826 M31 (OR) EN25

(OR) IS: 5517-1993, 22819-31, N110, CT3, MO.6

PART NO.	DESCRIPTIONS	NO OFF	MATERIAL	TREATMENT	REMARKS
	SIGNATURE & DATE.				SCALE NTS
TRACED					STORE DRG.NO.
DRAWN	<i>E. Venkatesh</i>				OPERATION NO.
CHECKED	<i>J. H...</i>				
OIC/D&DO	<i>J. Jawalan</i>				
OFFICER/PRODN.					
OFFICER/D&DO					
APPROVED ON. 3/05/2007					
		SUB: HAMMER CAM PLATE.		SCALE NTS	
		FOR: 20MM BOLT ASSY.		STORE DRG.NO.	
		OF: 14.5MM/20MM AMR.		OPERATION NO.	
		DES. REF. NO.			
		DRG. No.: 44P 03010*2			
		ORDNANCE FACTORY TIRUCHIRAPPALI-16.		SHEETS: 1	
				SHEET No.: 1	

DA. NO. 009/20
Dt. 10/7/19
DA. No. 050/19
Dt. 27.08.19

SIG. & DATE