

इन आरेखों तथा इसके साथ की सम्पूर्ण सामग्री का स्वत्वाधिकार भारत सरकार रक्षा मंत्रालय की भारतीय आयुध निर्माणियों के पास है। भारतीय आयुध निर्माणियों के महानिदेशक की लिखित अनुमति के बिना इनकी नकल या किसी भी रूप में इनके उद्धरण या इनमें समाहित सूचना किसी अनधिकृत व्यक्ति को उपलब्ध नहीं कराई जानी चाहिए।

THE COPYRIGHT OF THESE DRAWINGS AND ALL ATTACHMENTS THERE TO BELONGS TO THE INDIAN ORDNANCE FACTORIES, MINISTRY OF DEFENCE, GOVT. OF INDIA. THEY SHOULD NOT BE COPIED, REPRODUCED IN ANY WAY OR THE INFORMATION CONTAINED THEREIN MADE AVAILABLE TO UNAUTHORISED PERSONS WITHOUT THE WRITTEN PERMISSION OF THE DIRECTOR OF ORDNANCE FACTORIES.

मूलमाप व अन्वयोजन NOMINAL SIZE & FIT	विचलन DEVIATION
---	--------------------

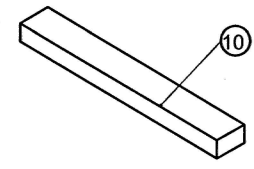
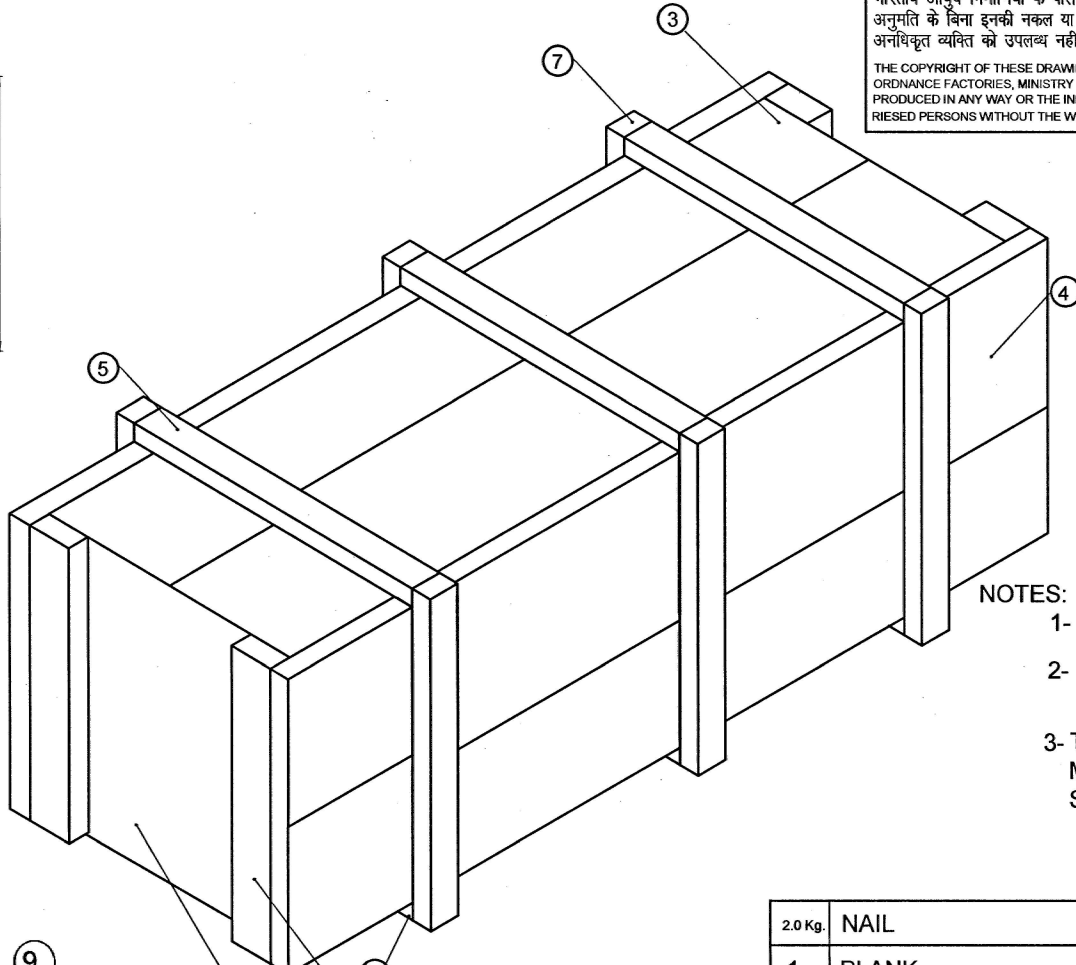
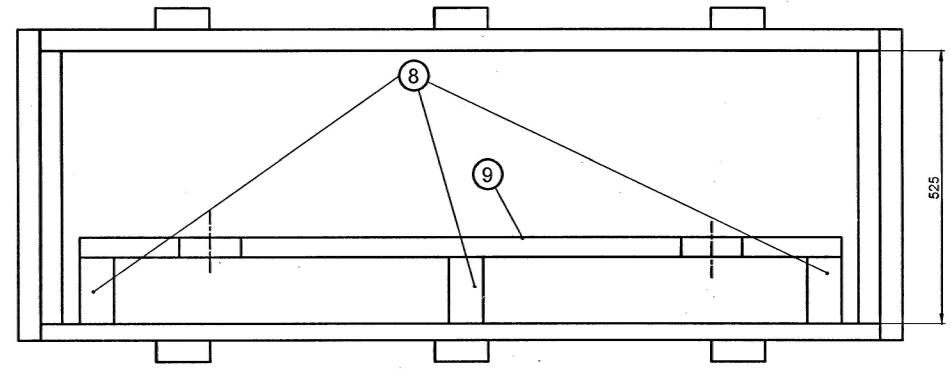
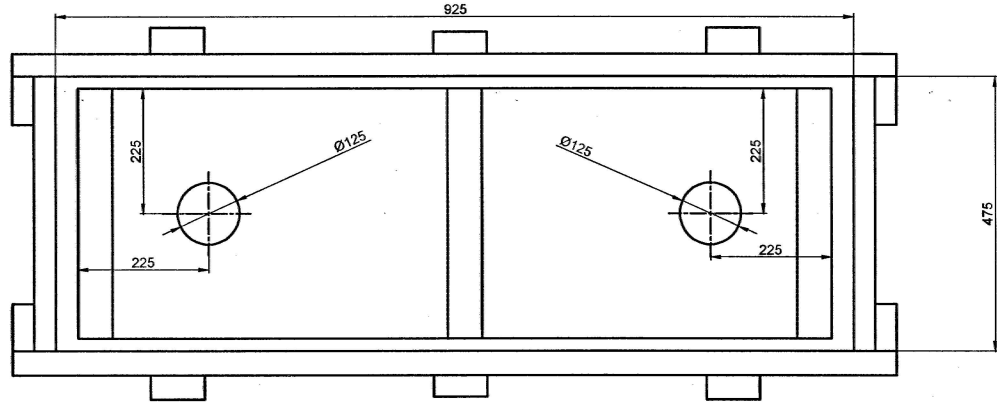

- NOTES:
- 1- SAMPLE TO BE APPROVED BEFORE BULK SUPPLY
 - 2- PART NO 8 ASSEMBLED WITH 7, PART NO 9 AND PART NO 10 TO BE SUPPLIED IN LOOSE CONDITION
 - 3- TIMBER FIR WOOD AS PER IS : 6662-1972. MOISTURE CONTENT 12% MAX AND TIMBER FIR WOOD SHOULD BE FREE FROM OBJECTIONABLE KNOTS

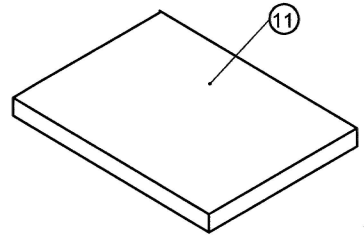
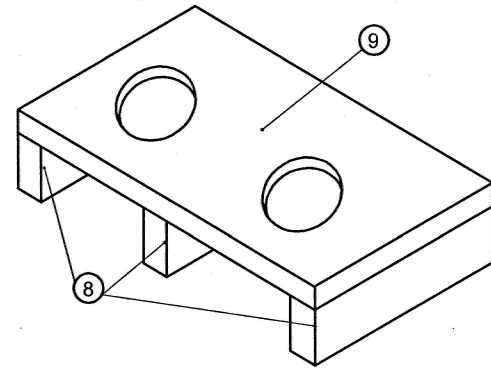
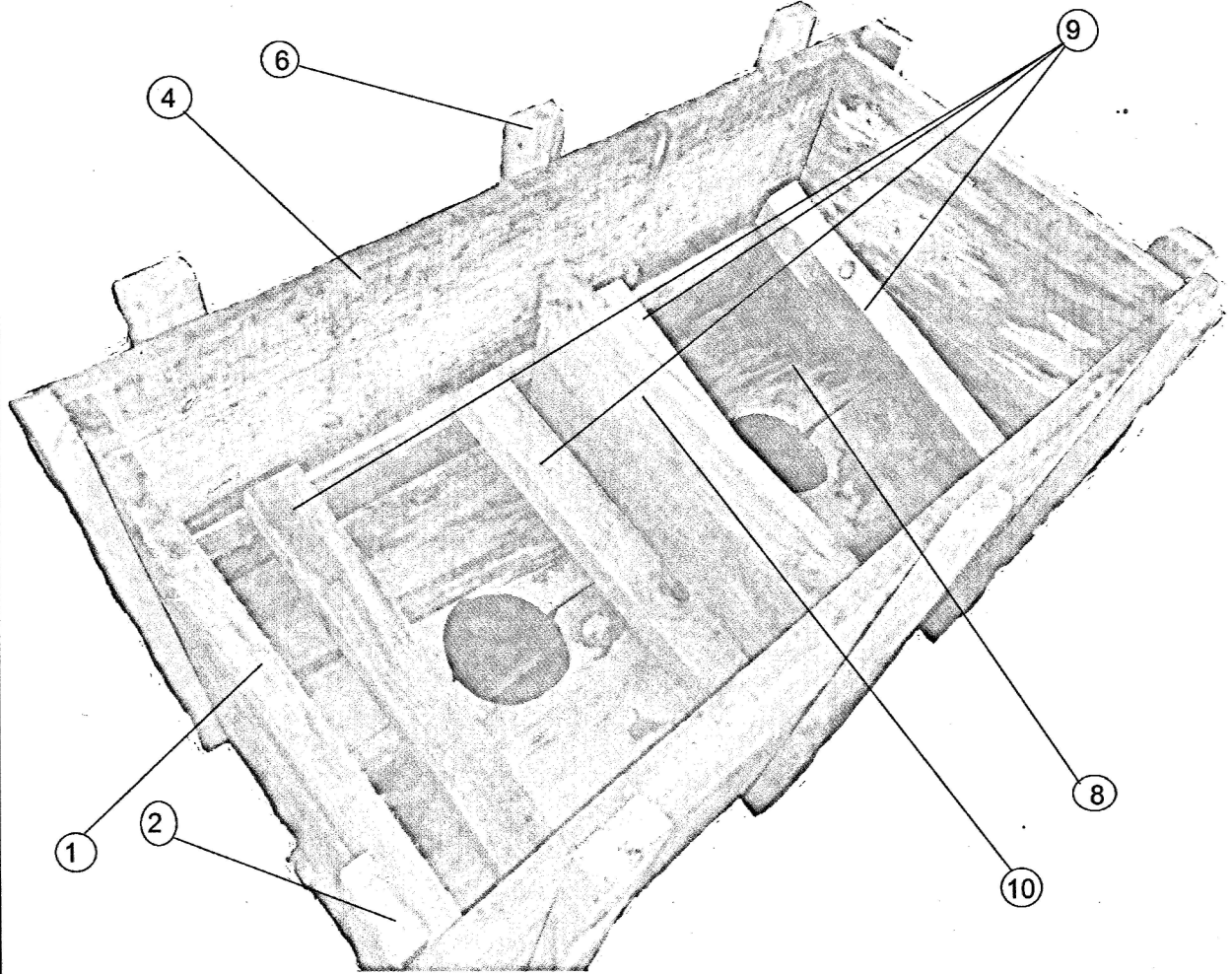

संख्या NO.OFF	विवरण DESCRIPTION	पुर्जा क्र. PART NO.	पदार्थ MATERIAL	मानक STANDARD	परिमाण DIMENSIONS	अभ्यासित REMARKS
2.0Kg	NAIL	12	IRON	2.5 INCH.		
1	PLANK	11	FIR WOOD	465X25X250		
1	PLANK	10	FIR WOOD	465X50X50		
1	PLANK	9	FIR WOOD	900X450X25		
3	PLANK	8	FIR WOOD	450X50X150		
6	PLANK	7	FIR WOOD	50X25X650		
3	PLANK	6	FIR WOOD	525X50X50		
3	PLANK	5	FIR WOOD	525X50X25		
4	PLANK	4	FIR WOOD	1025X25X260		
4	PLANK	3	FIR WOOD	975X260X25		
4	PLANK	2	FIR WOOD	50X25X575		
2	PLANK	1	FIR WOOD	475X25X525		

सामान्य सहिष्णुता GENERAL TOLERANCE		संख्या संबंधित पुर्जा का आरेख क्र. NO.OFF DRG. NO. OF ASSOCIATED PART		सूचक संशोधन INDEX ALTERATION	दिनांक नाम DATE NAME
रेखिक परिमाण LINEAR DIMENSION		मापमान SCALE		आरेखित DRAWN	
0-6 ±0.1		NTS		2017 24/12	
6-30 ±0.2		FOR FINAL REDUCTION GEAR UNIT		JPSY	
30-120 ±0.3		CODE-15		10/4	
120-315 ±0.5		मशीनी औजार आदिरूप फैक्टरी, अम्बरनाथ MACHINE TOOL PROTOTYPE FACTORY, AMBERNATH		DO	
315-1000 ±0.8		कार्यालय OFFICE		द्वारा बदला REPLACED BY	
1000-2000 ±1.2		हेतु बदला REPLACED FOR		11/4	
कोणिक परिमाण ANGULAR DIMENSION		आरेखण क्र. DRAWING NO.		998 - PB - 3385	
1-10 ±1°		998 - PB - 3385			
10-50 ±30'					
50-100 ±20'					
>100 ±10'					
मापक 'यू एम' में VALUE IN 'mm'					
- >25					
∇ 8-25					
∇∇ 1.6-8					
∇∇∇ 0.025-1.6					
∇∇∇∇ <0.025					