

DRG.
No.:

PROVISIONAL

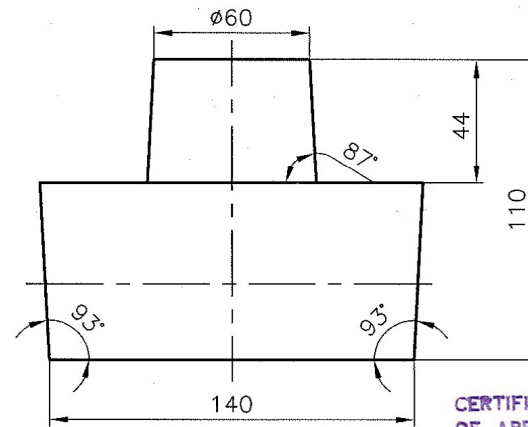
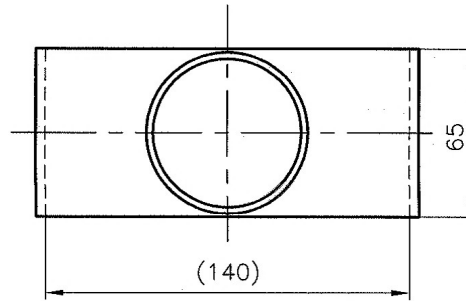

MATERIAL:-

- STEEL - 35XH2MØA-W-OCT3-98-80 (OR)
- STEEL - BS:970 Pt.1 1983 Gr.826 M40 (OR)
- STEEL - BS:970 Pt.3 1991 Gr.709 M40 (OR) En-19

NOTE:

1. DRAFT ANGLE - 3°
2. NON SPECIFIED RADII - 2mm
3. FORGING ARE TO BE SUPPLIED IN NORMALIZED AND TEMPERED CONDITION. HARDNESS: 240-300 BHN.
4. THE REMAINDER OF THE BURR ON THE JOINT SHOULD NOT EXCEED 0.9mm
5. END BURR SHOULD NOT EXCEED 5mm
6. FORGINGS SHALL CONFIRM TO AS PER IS: 3469 - 1974
7. FORGINGS SHOULD BE SUPPLIED IN SHOT BLAST CONDITION.
8. FORGINGS SHOULD BE FREE FROM DEFECTS SUCH AS DEEP PIT MARK, LAPS, CRACKS, DENTS SCALE AND ANY OTHER FORGING DEFECTS.

DIMENSIONS ARE IN mm.
UNTOLERATED DIMNS. AS PER IS : 2102 (MED)

CERTIFIED CORRECT COPY
OF APPROVED DRAWINGS
AT THIS DATE.....

17.11.2020

Design & Drawing Office
Ordnance Factory,
Tiruchirappalli-620016

HOS/PS-2

UN CONTROLLED COPY

PART NO.	DESCRIPTIONS	NO OFF	MATERIAL	TREATMENT	REMARKS
⊕	SIGNATURE & DATE.	SUB: FORGING FOR PRE-MACHINING			SCALE 1:2
TRACED		FOR: FRONT FRAME			STORE DRG.NO. 30P 1104
DRAWN	<i>[Signature]</i> 11/2/18	OF: 40mm MGL			OPERATION NO.
CHECKED	<i>[Signature]</i> 11/2/18	DES.REF.NO. NT/DDO. Dt. 01/12/18			
HOS/D&DO	<i>[Signature]</i>	DRG. No.: 30C 1104 002 A3			
NODAL OFFICER FOR MSL.		 ORDNANCE FACTORY TIRUCHIRAPPALLI-16.			SHEETS: 1
OFFICER/D&DO					SHEET No.: 1
AMENDMENTS	SIG. & DATE	APPROVED ON. 01/12/2018			