

пер. размер. ПИ 511-79

30M1-0.8.11M6.4E.2.7. ПИ 511-79

2009

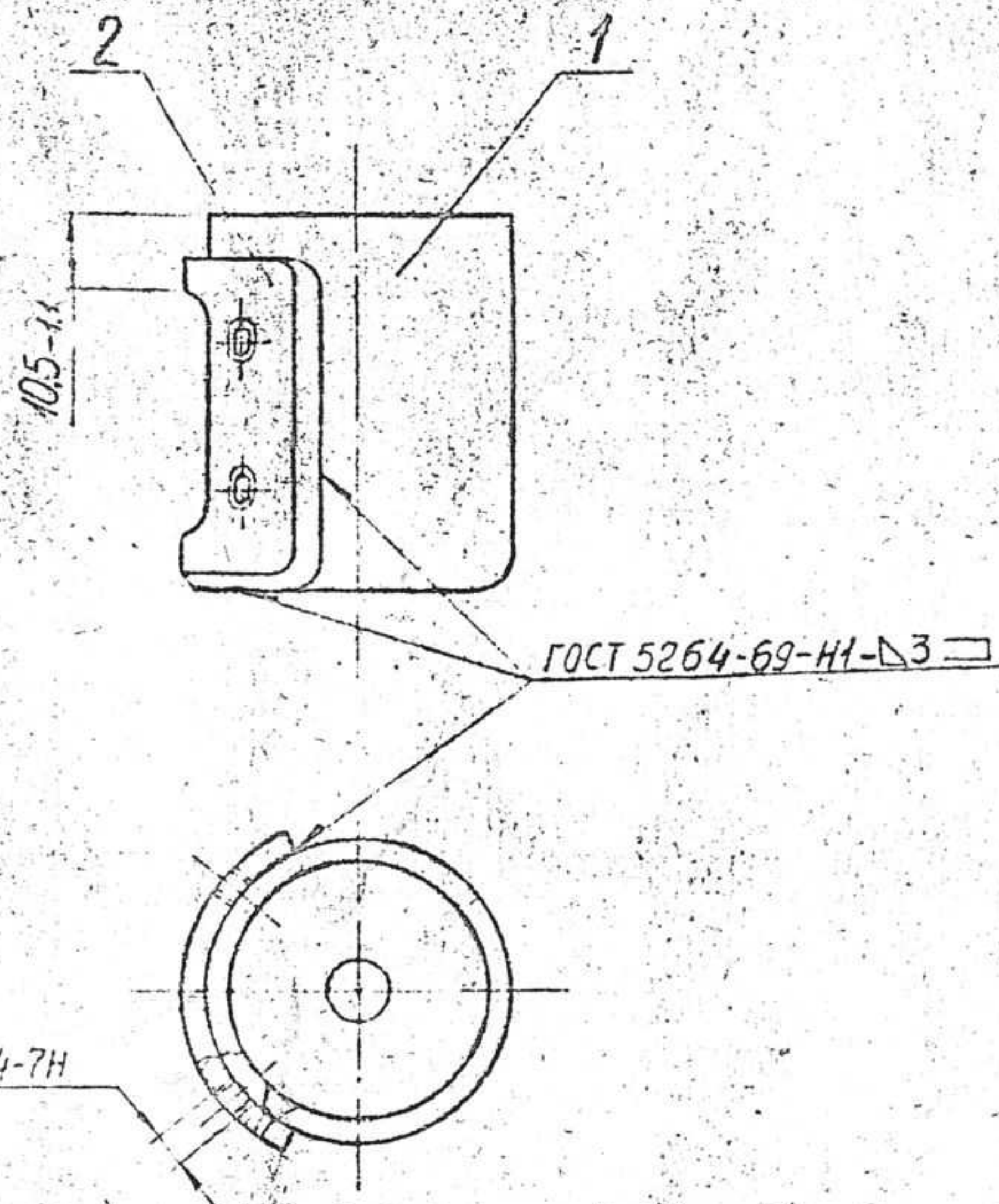

1. Eccentricity of opening in part, Ref, No2. with respect to opening in parts Ref, 1. should not exceed 0,25mm.
2. Coating: Zinc plated, 9 microns thick, Chromized composition of solution for chromotizing as per 4-252.78.
3. Insted of welding, brazing with copper is allowed, before brazing with copper tack welding by spot welding at 3 to 4 points is allowed.

ЕСКД

PII-511-79CB

22 / 2602

SNO	SHT	DOC NO	SIGN	DATE
DRAWN		S.Gopal		11/12
EDT,CHKD		A.K. KUNDU		12/12/85
F/M,DC.		S.R.Nair.		14-12-82
DIV.OFFR		A.K.KUNDU		3.01.85
		NAME	SIGN	DATE

CASING WITH COVER PLATE

Assembly drawing.

SHEET	WEIGHT	SCALE
5	148g	1:1
TOTAL SHEETS		
ORDNANCE FACTORY PROJECT HYDERABAD		

Easy2Convert

Rz 160 (✓)

DP-511-80

PII-511-79

A-A

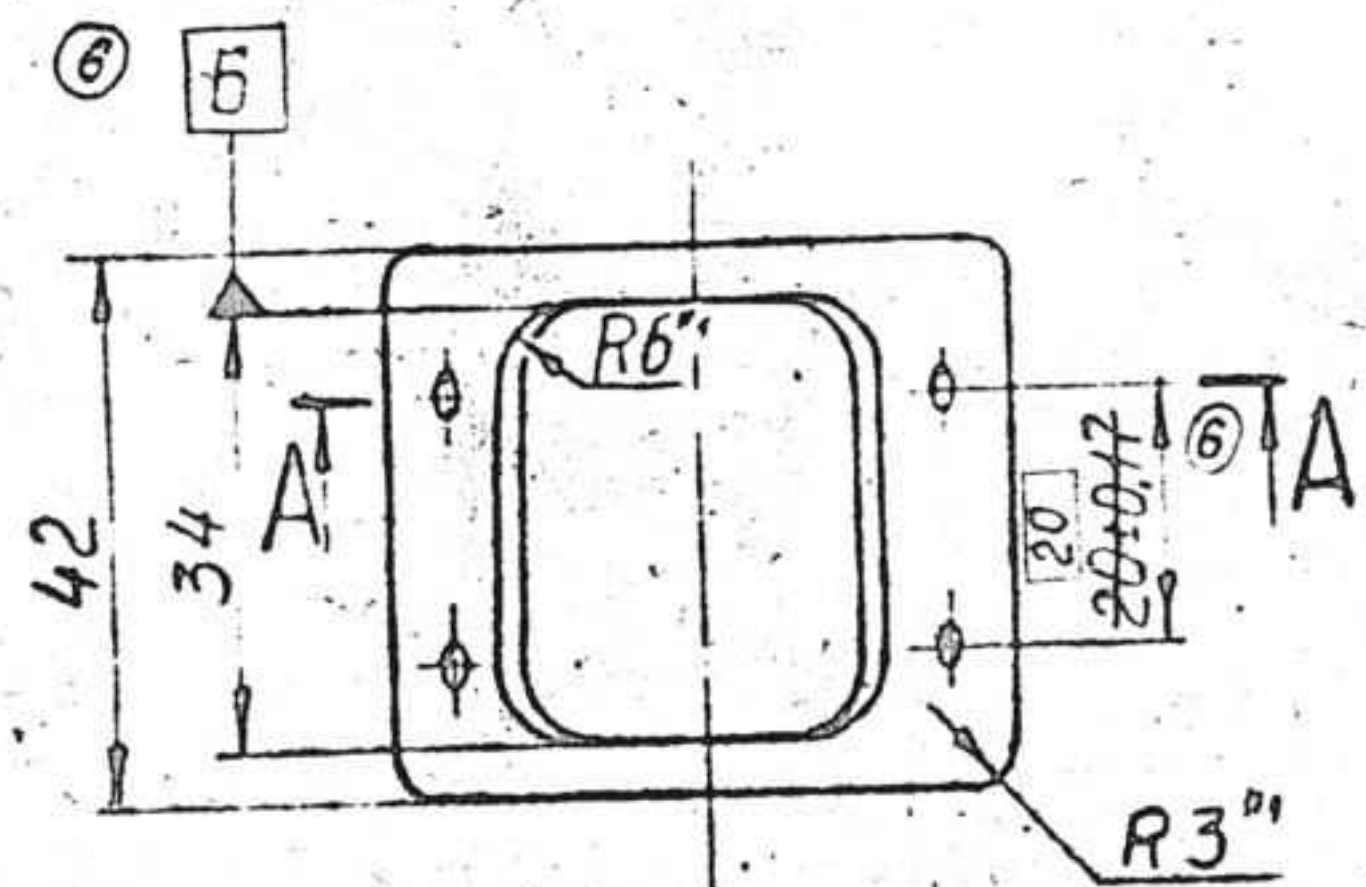
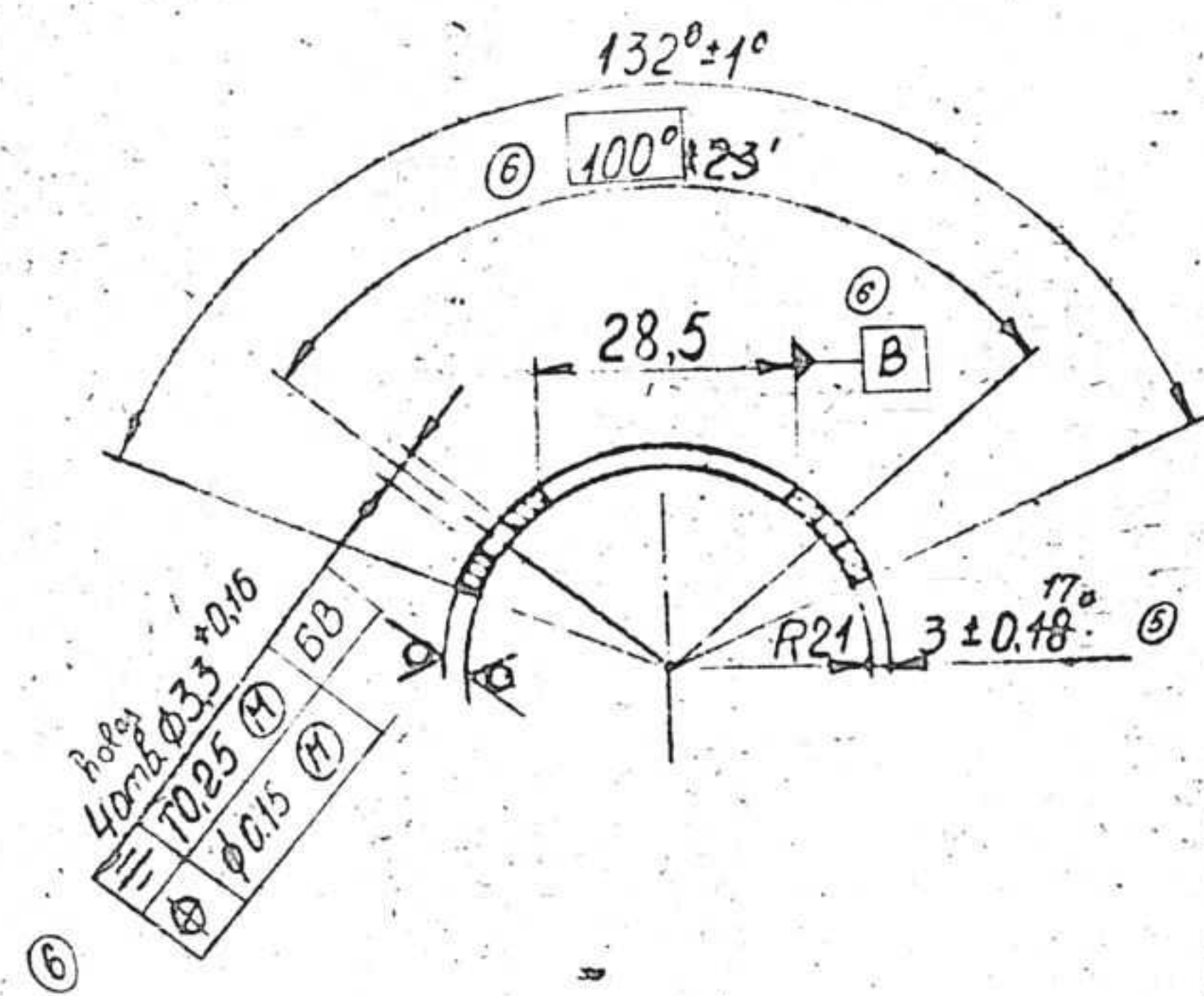

1. Alternate material: Sheet A3.0 GOST19904-74
- 2.* Dimension. is given for reference
3. Un-specified limit deviations of dimensions ±0,25mm.
- 4.* Dimensions are provided with tool.
5. Assymetry of dimension arrangements with respect to axes is with-in tolerance limits.

4522

45004

44 D-602 ECKD

DP-511-80

SNO	SHY	DOC NO	SIGN	DATE
DRAWN	S.Gopal			12/12
EDT,CHKD	A.K. RUNDU			13/12
F/M,DC	S.R.Nair			14/12
DIV.OFFR	A.K. RUNDU			3.01.89
	NAME	SIGN	DATE	

COVER PLATE.

SHEET	WEIGHT	SCALE
5	272	1:1

Sheet 53.0 GOST19904-74

II-BГ-08KП GOST9045-70, HYDERABAD

TOTAL SHEETS
ORDNANCE FACTORY
PROJECT
HYDERABAD

Easy2Convert

DN 1 NR 3

2.5

Лист № 01
РП-715-92

Справ. №

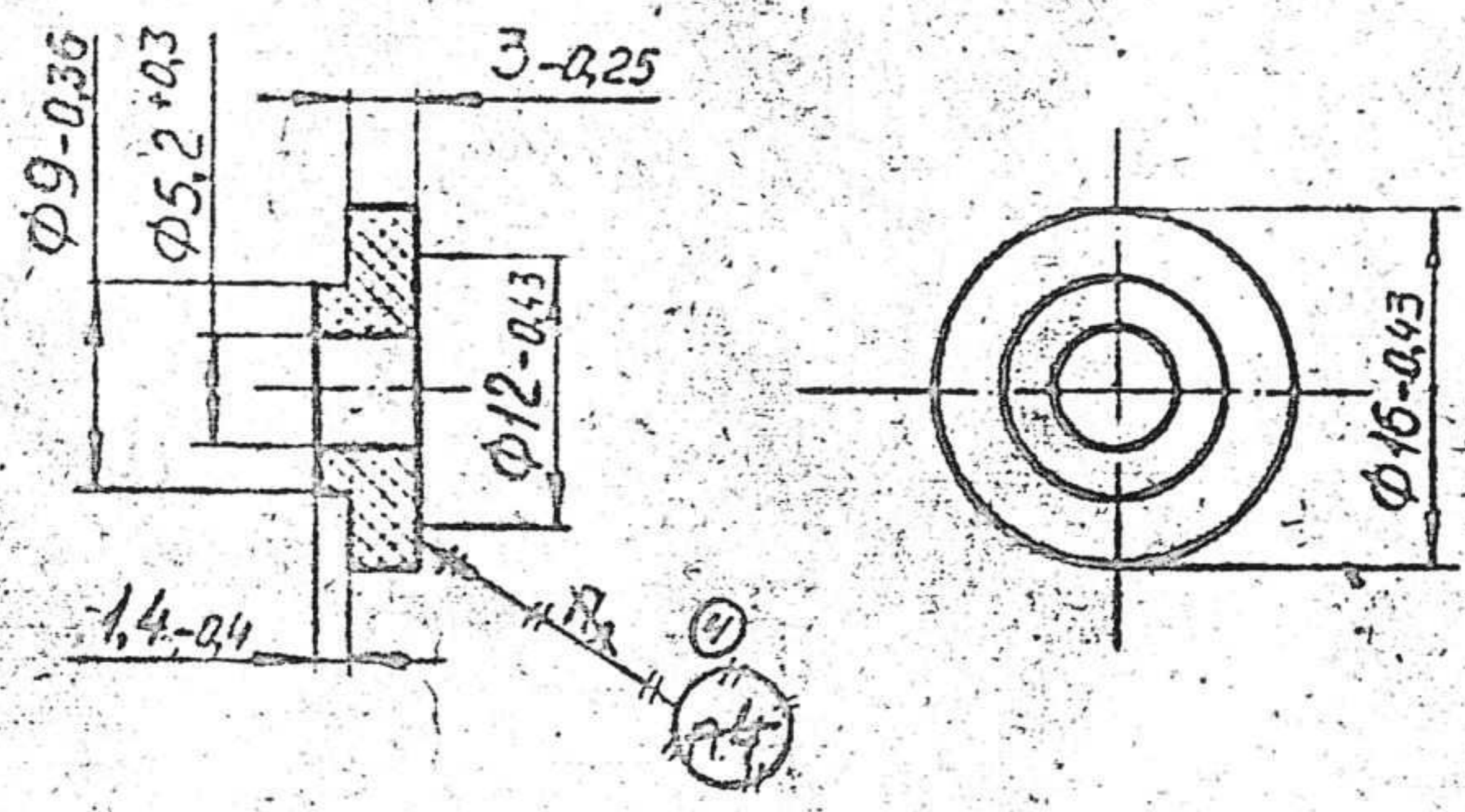

1. Alternate material is moulding material ACB-2-P-2M or ACB-4-P-2M. Brand, O GOST17478-72.
2. Pressing slope is 1° to-wards the increase of dimension.
3. Other requirements as per OST B 84-1602-78
4. Subject to heat treatment at 140° for 2 hours.

13342

24/2602

16

ЕСКД

РП1.003

SNO	SHY	DOC NO	SIGN	DATE
DRAWN		S.Gopal		11/12
EDT,CHKD		A.K. Kurdu		13.12.12
F/M,DC		S.R.Nair		14.12.84
DIV.OFFR		A.K. Kurdu		3.01.85
		NAME	SIGN	DATE

BUSHING

SHEET	WEIGHT	SCALE
5	0.001	2:1
TOTAL SHEETS		
ORDNANCE FACTORY PROJECT HYDERABAD		

Moulding material AF-4B.
GOST20437-75.

3-5-A4-1-5-1/23

V(V)

Склад № 1157
ПН-715-92

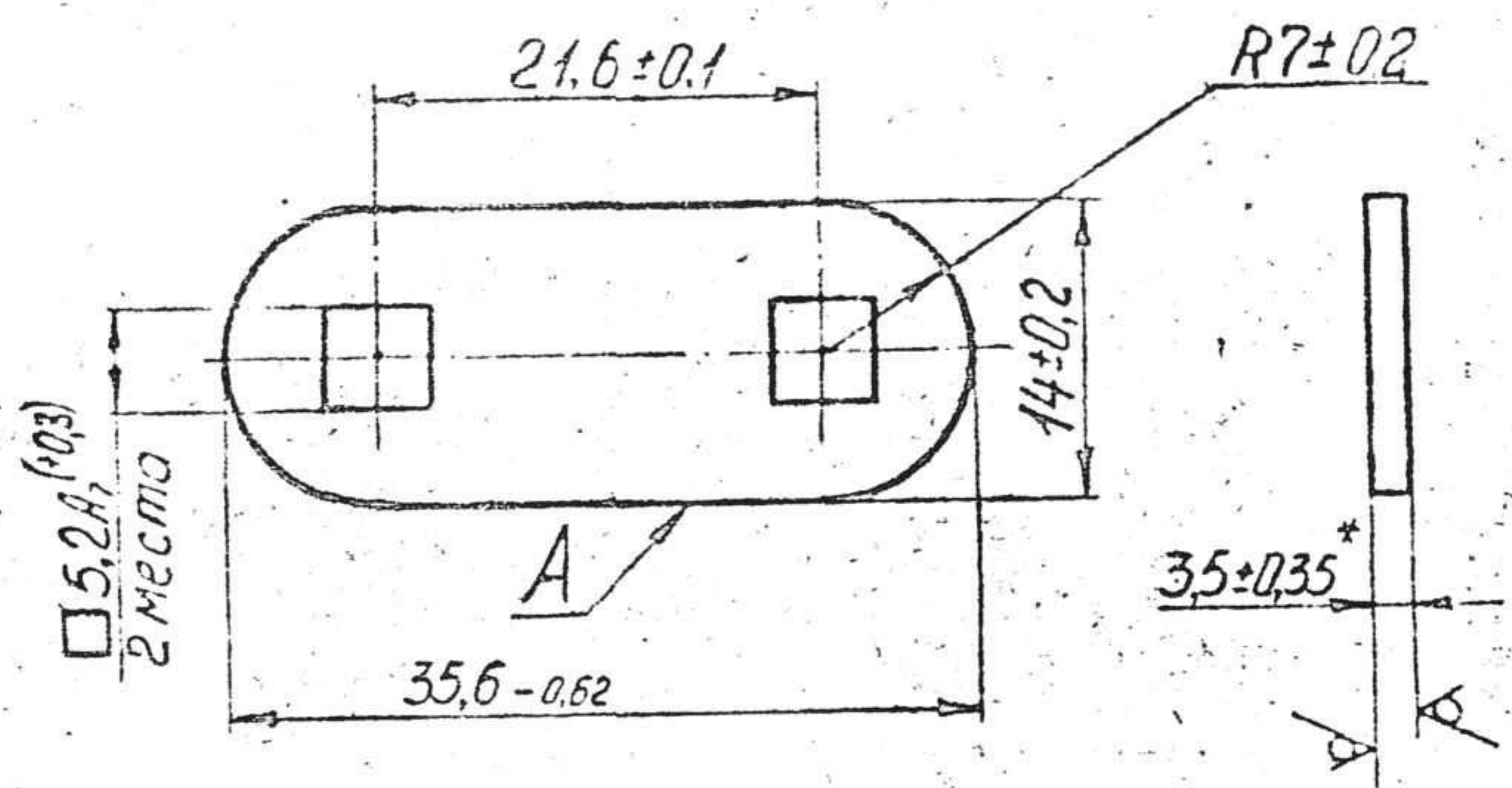

1. Alternate material is textolite brand Б, GOST2910-74.
2. *Dimension. given for refrence.
3. Coating: impregnating with varnish П-95, GOST8018-70.
4. Local spalling of core on surface A to ... depth not exceeding 1.5mm is allowed, total length of local spalling should not exceed 30 % of the whole contour.

18801
10887

41
D-602
ССКД

ПН-161-Б8

NO	SHY	DOC NO	SIGN	DATE
DRAWN		S.Gopal.		12/12
EDT/CHKD		A.K. DUDY		13-12-82
F/M, DC		S.R.Nair.		14-12-84
DIV. OFFR		A.K. KONDU		3-01-85
		NAME	SIGN	DATE

TERMINAL
PANEL

Textolite A-3,5
GOST2910-74.

SHEET	WEIGHT	SCALE
5	1,82	2:1
TOTAL SHEETS		
ORDNANCE FACTORY PROJECT HYDERABAD		

Easy2Convert

ПТ-511-67

K2 80
✓(V)

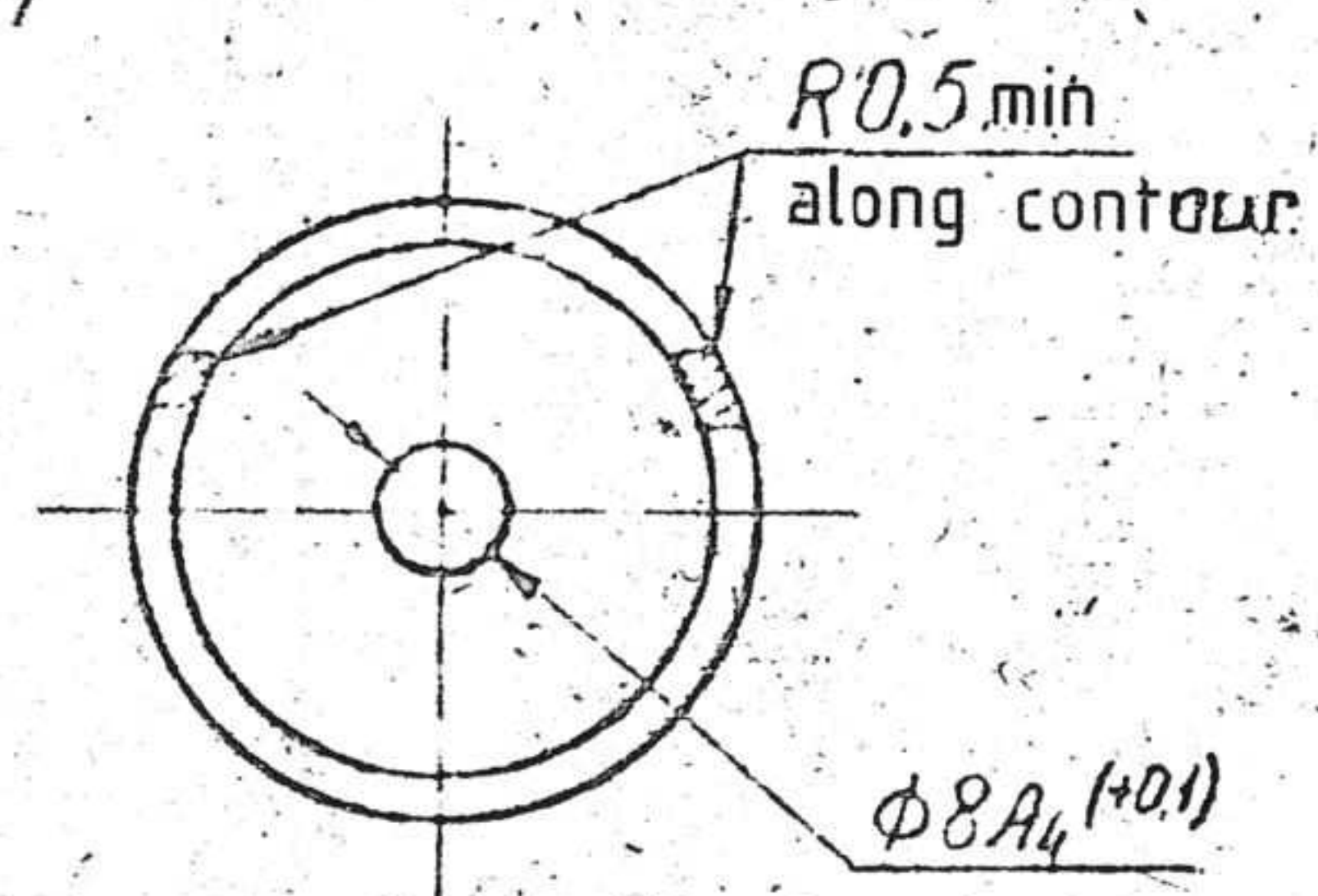
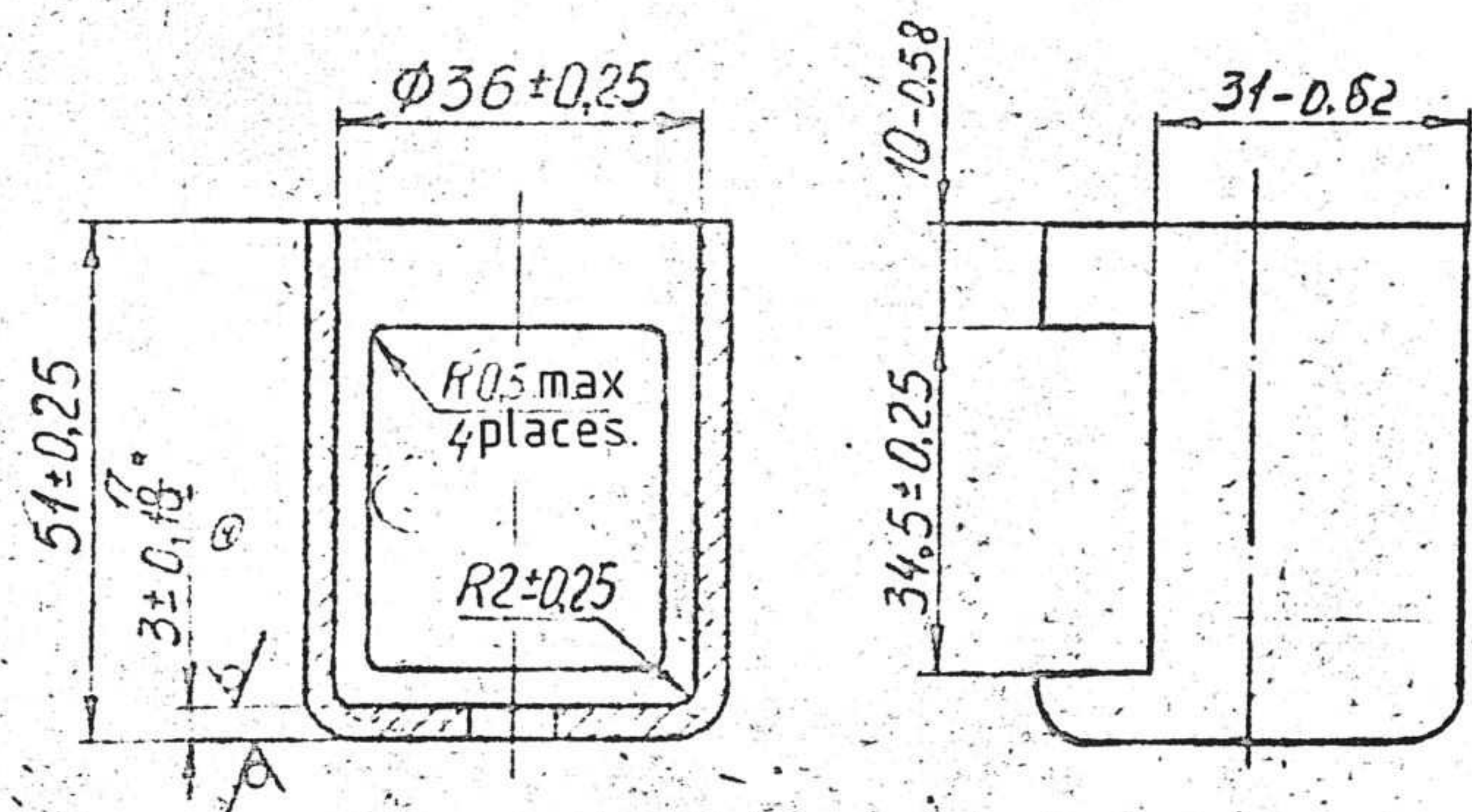

1. Dimension is given for refrence.

3240

43
D-602

ПТ-511-67

SHEET WEIGHT SCALE			
SNO	SHY	DOC NO	SIGN DATE
DRAWN	S.Gopal		12/12
EDT, CHIC	A.K. KUNDU		12/12
F/M, DC	S.R. Nair		14/12/84
DIV. OFFR	A.K. KUNDU		3.01.85
NAME		SIGN	DATE
CASING.			
Sheet		B3,0 GOST19904-74	
		II-BG-08KA GOST9045-70.	
TOTAL SHEETS			
ORDNANCE FACTORY PROJECT HYDERABAD			

Дуплом 11
3-5-A4 1-5-1/1/8

26-064 IX

AZOD
V/V

Справка №
Проект
ПН-1

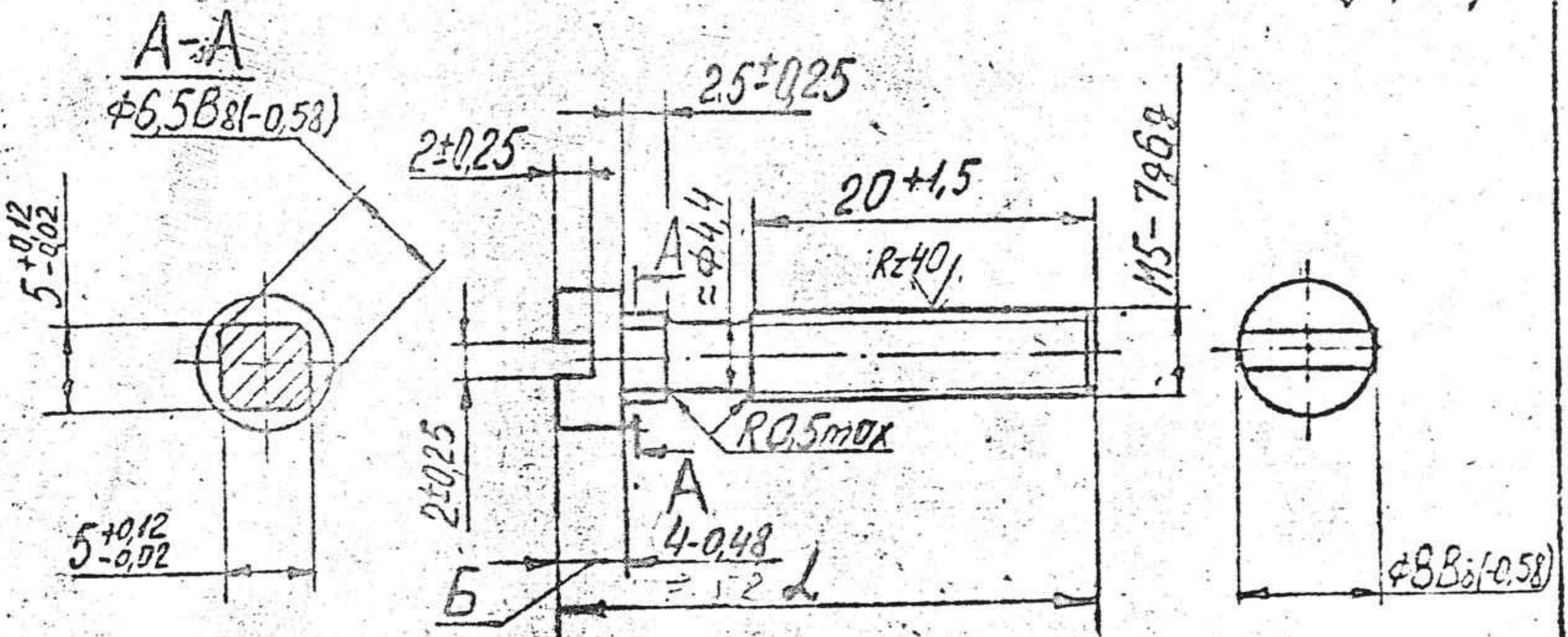

Designation		Mass
X1-490-92	32-1	4.4
-01	36±0.6	4.9.

1. Burrs are allowed on internal side of head to-wards the stem within height B
2. Coating tin-bismuth. (99,8), 9 microns.
3. Other technical requirements as per GOST 1759-70.

Справка №
Подпись и дата

6449

42
D-602
ECLD

(34)

X1-490-92

SN	SH	DOC NO	SIGN	DATE
DRAWN		S.Gopal		12/12
EDT,CHKD		A.K.KUNDU		13.12.85
F/M,DC.		S.R.Nair.		12.12.84
DIV.OFFR		A.K.KUNDU		3.01.85
		NAME	SIGN	DATE

TERMINAL BOLT

Steel 10 GOST 1050-74.

SHEET	WEIGHT	SCALE
	CM	2:1
TOTAL SHEETS		
ORDNANCE FACTORY PROJECT HYDERABAD		

3-5-AA-1-S-1/25

Rz 80

✓(✓)

ПП-1

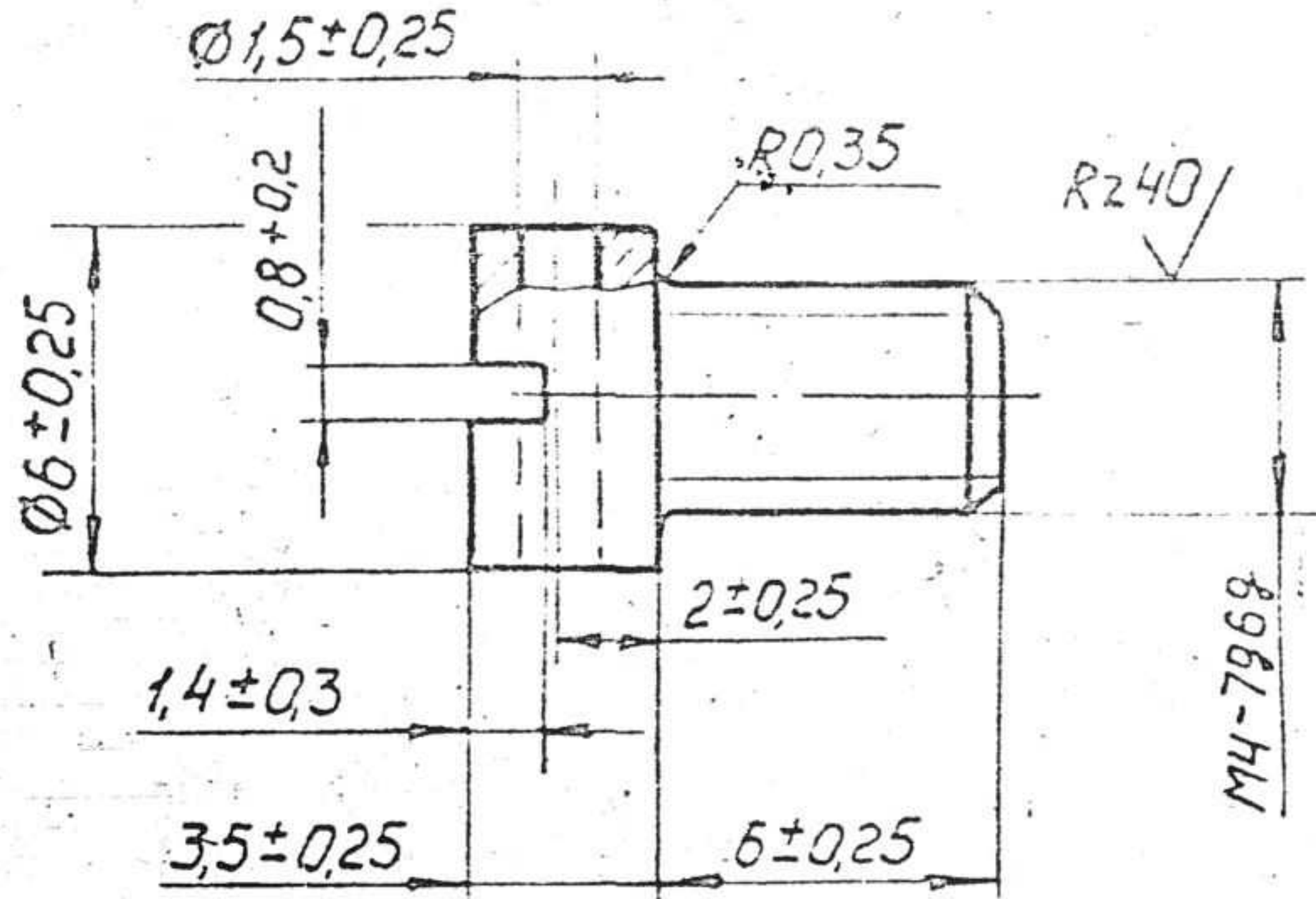

M4-7968

ЕСКД

Designation.	Coating.
X1-9895.	Zinc plated, 6 microns, chromated composition of solution for chromating as per И-252-78.

1. Alternate material is steel A12, GOST 1414-54.
2. Limit deviation from alignment of axes of head and slot with respect to axis of stem is 0,15mm.
3. Technical requirements as per GOST 1759-70.

54

восстановлен с подлинника.

2651

X1-9895

SCREW

SHEET	WEIGHT	SCALE
	5,1252	5:1
TOTAL SHEETS		
ORDNANCE FACTORY PROJECT HYDERABAD		

SN	SHT	DOC NO	SIGN	DATE
DRAWN		S. Gopal		12/12
EDT	CHKD	A.K. KUNDU		13-12-84
F/M, DC		S.R. Nair		14-12-84
DIV. OFFR		A.K. KUNDU		3.01.85
		NAME	SIGN	DATE

Wire 3,46-10 GOST 5663-79. Easy2Convert.com

3-5-A4

12

ОУССТРОИТЕЛЬ С ПОДПИСЬЮ

№ докум. 4333
 Дата 39.12.82
 Проект № 10630
 Изд. № 1
 Мат. № 1
 М.П.

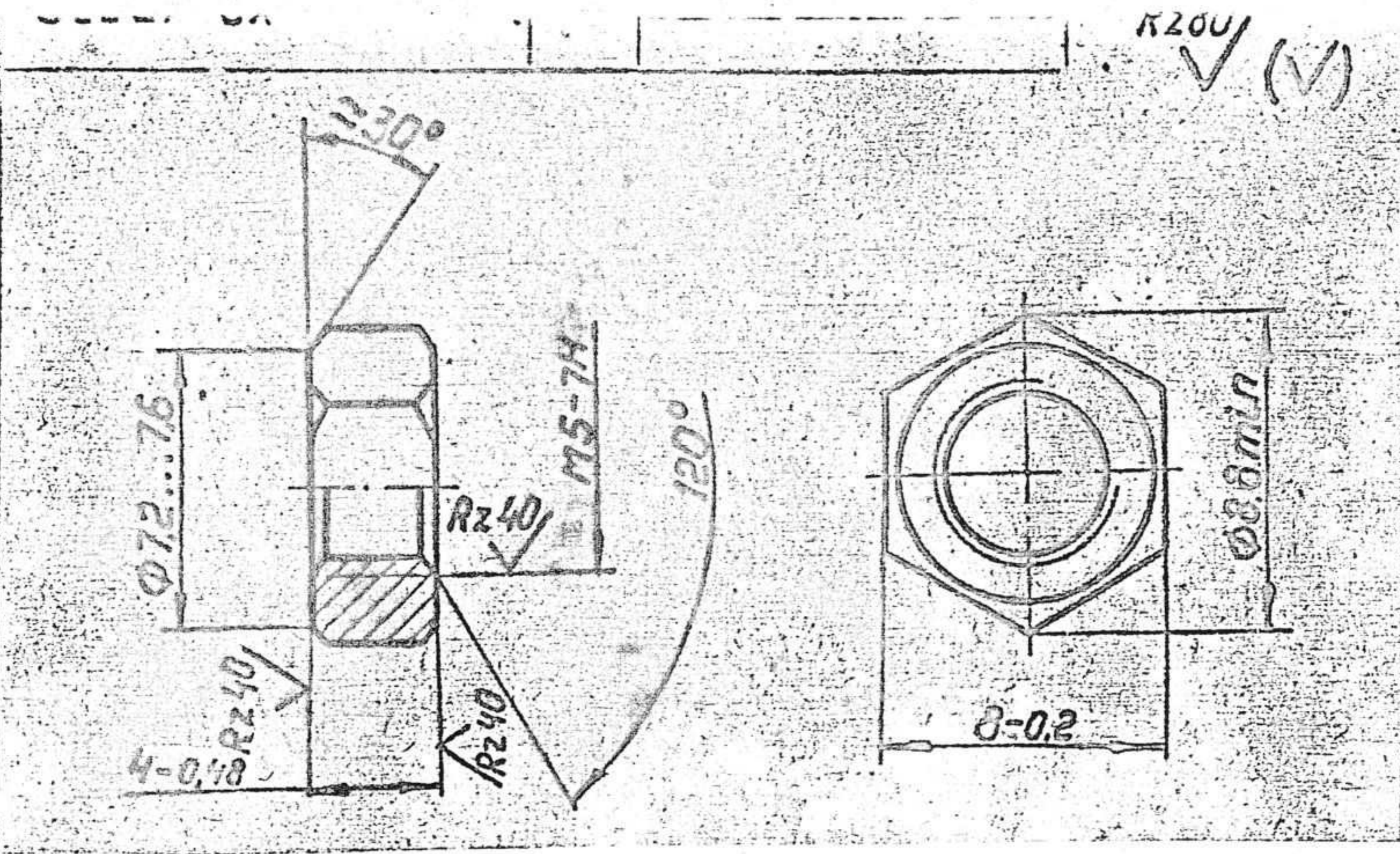

Designation	Coating.
X2-10630	Zinc plated, 6 microns, chromated

1. Alternate material is steel 10, GOST 1050-74
2. Limit displacement of axis of hole with respect to flats is 0.25 mm.
3. Other technical requirements as per GOST 1759-70.

ЕСКД

X2-10630

NUT

NO	SHT	DOC NO	SIGN	DATE
DRAWN		S.Gopal		12/12
EDT, CHKD		A.K. Kundu		13.12.82
F/M, DC.		S.R.Nair		14.12.82
DIV. OFFR		A.K. Kundu		2.01.83
		NAME	SIGN	DATE

SHEET WEIGHT		SCALE	
5	120	1:1	
TOTAL SHEETS			
ORDNANCE FACTORY PROJECT HYDERABAD			

Steel A12
GOST 1414-75

41-507 2A

12.00
V(N)

PPT-3001

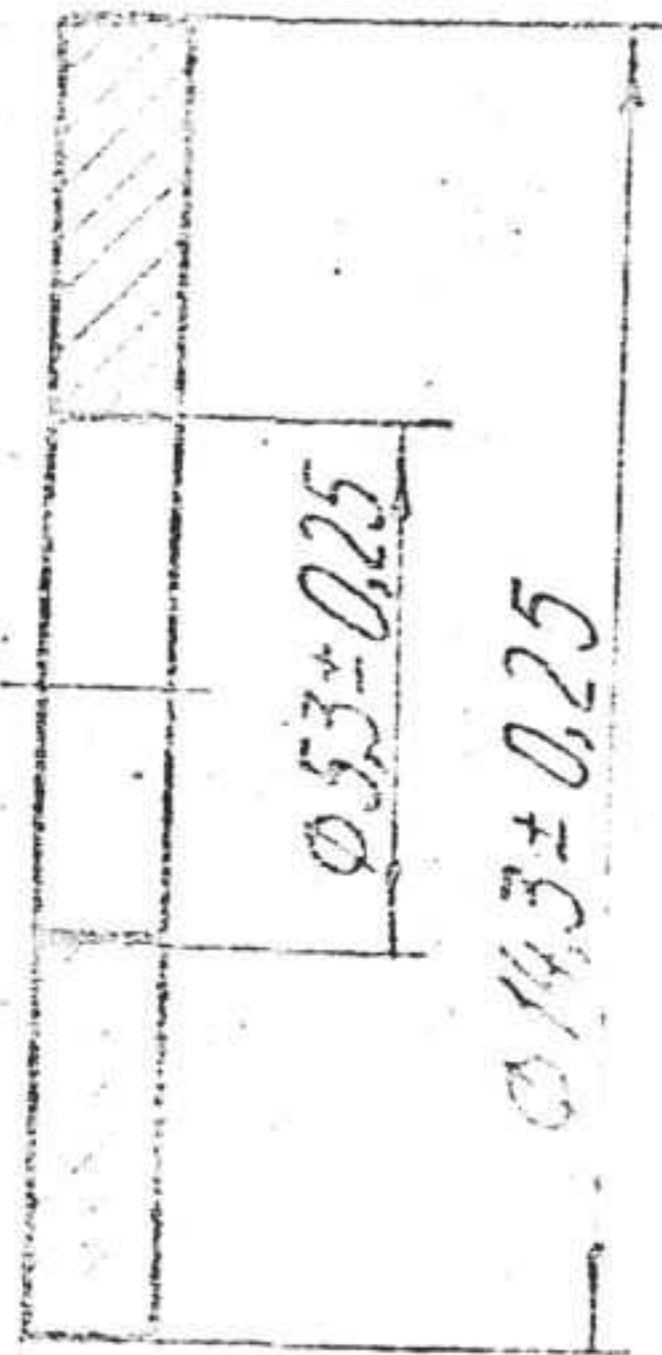

$1.5 \pm 0.11^*$

38
D-602

* Dimension is given for reference.

Designation	Coating.
X3-102-14	zinc-plated 6 microns, chromated. Composition of solution for chromating as per N.252-78.

PA
200
179

X3-102-14

SNO	SHT	DOC NO	SIGN	DATE
DRAWN		S.Gopal.		12.12
EDT, CHKD		AK DUBAY	Amout	13-12-84
S/M, DC		S.R.Nair.	SR	04-12-84
DIV. OFFR.		A.K.KUNDU	AK	3.01.85
		NAME	SIGN	DATE

WASHER

Sheet 5, 15 GOST 19904-74.
4-1-10 GOST 16523-70.

SHEET	WEIGHT	SCALE
	5.162	5:1
TOTAL SHEETS		
ORDANANCE FACTORY PROJECT HYDERABAD		

3-5-A4 1-5-1/27

RZ80 VI

Проб. номер РП-1

Стор. №

Информация

Информация

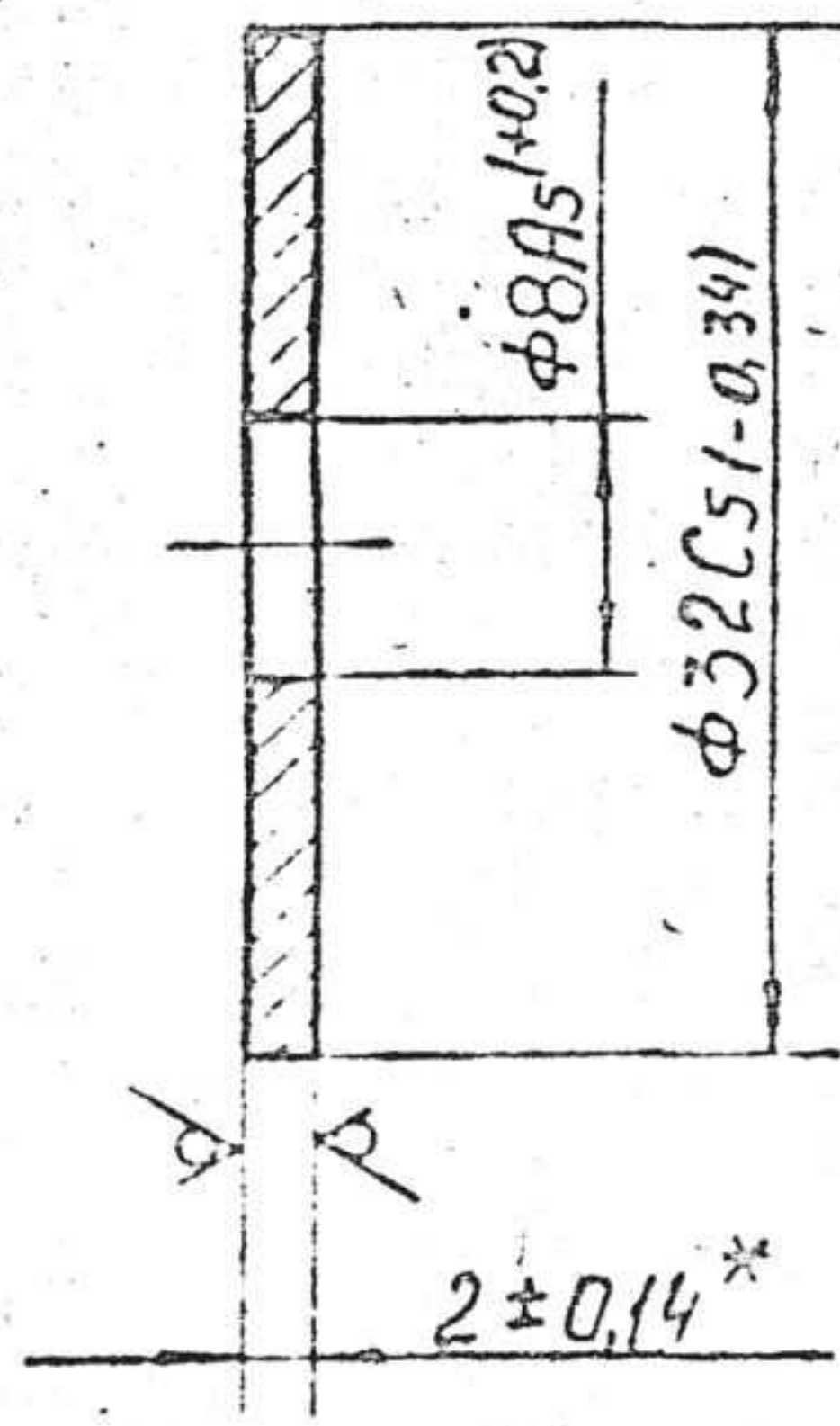

1. Alternate material sheet $\frac{52 \text{ GOST19904-74}}{4-II \text{ 10 GOST16523-70}}$
2. * Dimension is given for reference.
3. Coating (zinc plated, 21 microns, chromated) composition of solution for chromating as per U-252-78.

ECKI

(2)

X3-9660

WASHER.

SHEET WEIGHT SCALE

5 122 2:1

TOTAL SHEETS

ORDNANCE FACTORY
PROJECT
HYDERABAD

SNO	SHY	DOC NO	SIGN	DATE
DRAWN		S.Gopal.		12/12
EDT,CHKD		A.K. KUNDU		13-12-82
F/M, DC		S.R.Nair		14-12-82
DIV. OFFR		A.K. KUNDU		3.01.85
		NAME	SIGN	DATE

Sheet $\frac{52 \text{ GOST19904-74}}{4-II \text{ 10 GOST16523-70}}$

Восстановлен с подлинника.

РП-1

$\phi 15,7 (+0,24)$

$\phi 33,8 C5 (-0,34)$

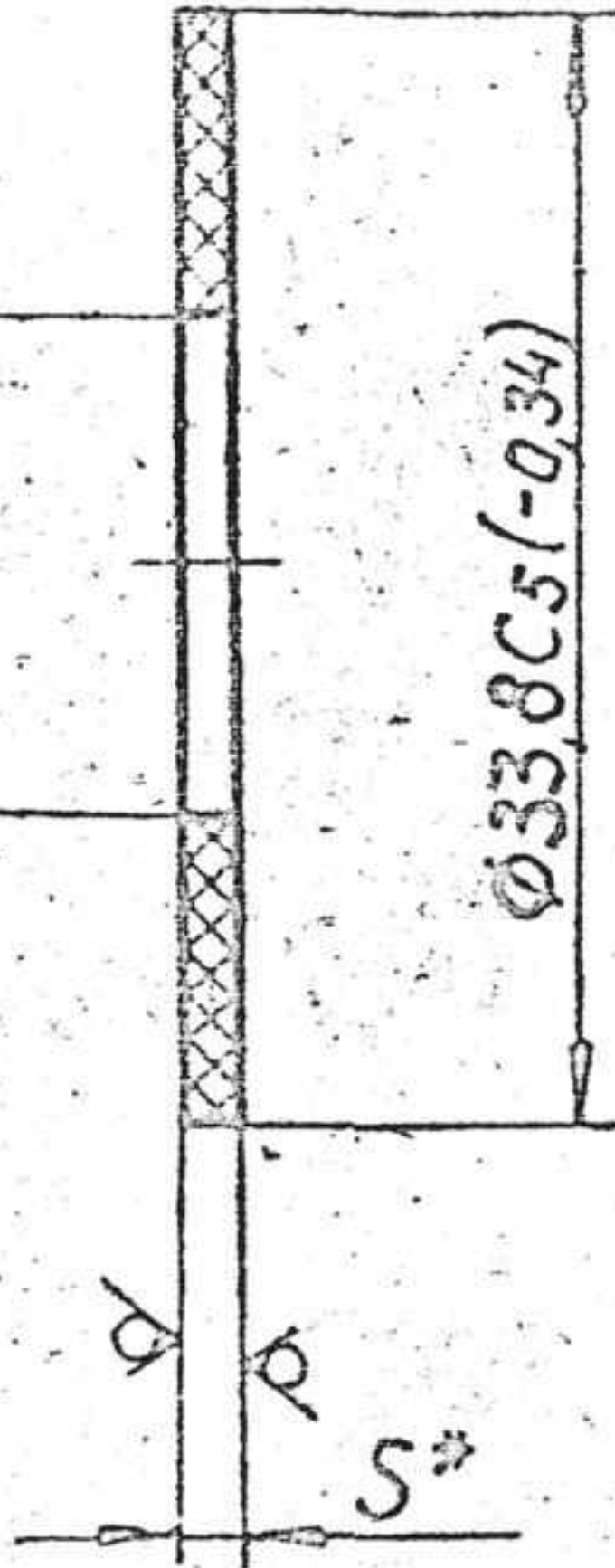

Rz 80
V (M)

37
D.602

ЕСКД

Designation	Material	S*	Alternate Material.	Coating.	Allowed coating.
X5-9960	Textolite A-1 GOST2910-74.	1±0.15	Textolite Б.1. GOST2910-74.	Varnish 70-95 GOST8018-70	Varnish M/1.92(1) GOST15865-

*Dimension is given for reference.

X5-9960

SNO	SHT	DOC NO	SIGN	DATE
	DRAWN	S.Gopal		12/12
	EDT,CHKD	A.K.DUBAY		13.12.89
	F/M, DE	S.R.NAIR		14.12.89
	DIV.OFFR	A.K.KUNDU		15.01.89
		NAME	SIGN	DATE

WASHER.

See table.

SHEET	WEIGHT	SCALE.
5	12	2:1
TOTAL SHEETS		
ORDNANCE FACTORY PROJECT HYDERABAD 22		

305/A4 5/10

СТУП - А

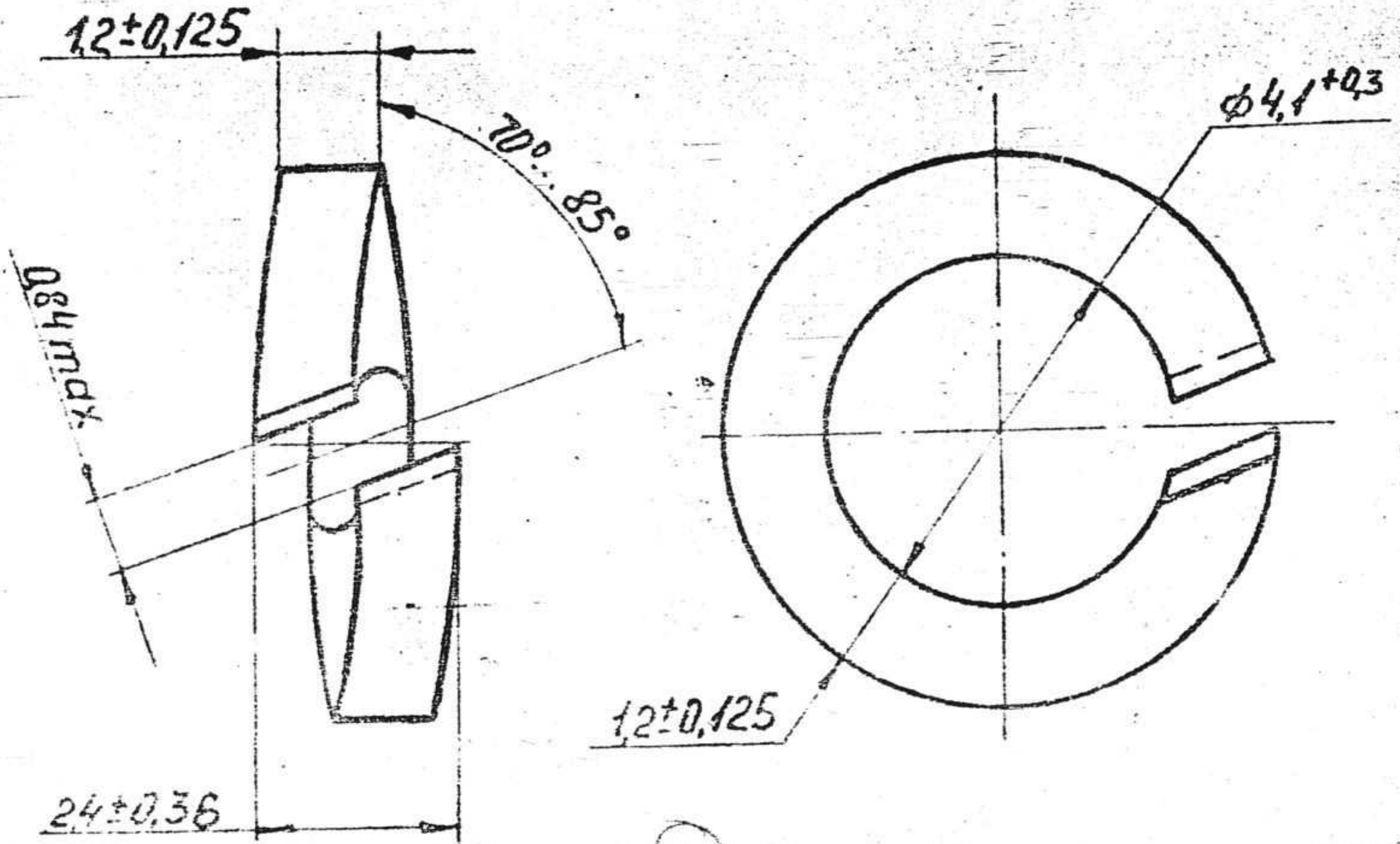

МН-1

Designation.	*	Coating	Coating is allowed
X-1012	06	Chemically, parkerized, oiled.	Chemically, oxidised, oiled, zinc, plated 6 microns chromatised, cadmium plated 6 microns chromatised.

Technical requirements as per GOST 6402-70.

Восстановлен с подлинника.

8856

31
D-602

24

ECKA

X-1012

NO	SHT	DOC NO	SIGN	DATE
DRAWN		S.Gopal.		12/12
EDT,CHKD		A.K. KUNDU		12-12-81
F/M,DC		S.R.Nair.		14-12-81
DIV.OFFR		A.K. KUNDU		3-01-85
		NAME	SIGN	DATE

WASHER
465F * GOST 6402-70
Steel 65 Convert
GOST 1050-74

SHEET	WEIGHT	SCALE
5	01892	10:1
TOTAL SHEETS		
ORDNANCE FACTORY PROJECT HYDERABAD		

1001-X



15-4
Исп. проект

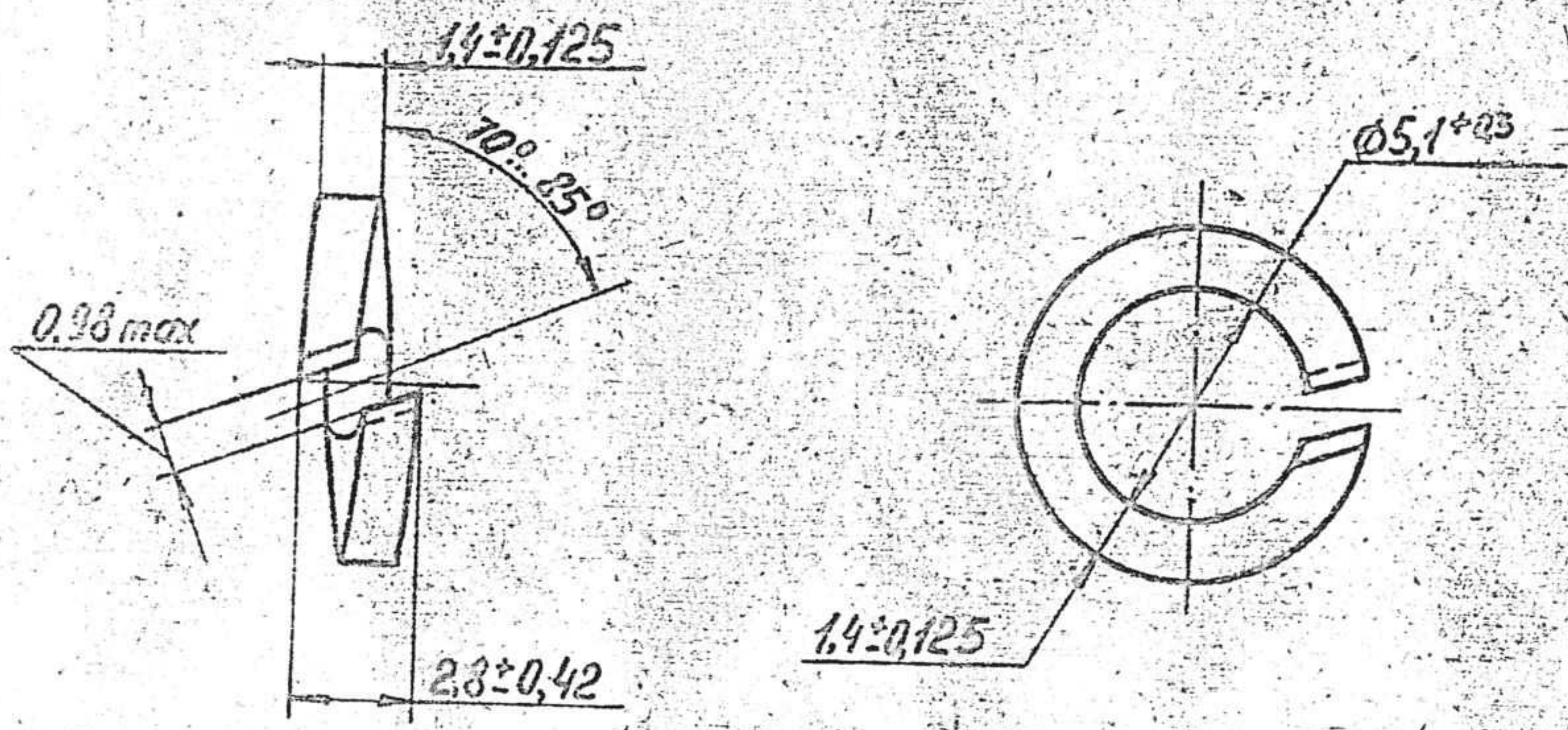

Designation	*	Coating.	Allowed coating.
X-4001	06	Chemically Parkirized. oiled.	Chemically, oxidised. oiled, cadmium plated, 6 microns chromitized.

Technical requirements as per GOST6402-70.

Восстановлен с подлинника.

18361
Исп. проект

34
D-602

(26)

ЕСКД

X-4001

SN	SHT	DOC NO	SIGN	DATE	WASHER.	SHEET	WEIGHT	SCALE
DRAWN		S.Gopal		12/12		565Г GOST6402-70.	5	0.315g
EDT,CHKD		А.К.Кунду	AK	13.12.80	TOTAL SHEETS			
F/M,DC.		S.R.Nair.	SR	14/12/80	steel 65Г GOST1050-74.	ORDNANCE FACTORY PROJECT HYDERABAD		
DIV.OFFR		A.K.KUNDU	AK	5.01.85				
		NAME	SIGN	DATE				

Easy2Convert
www.easy2convert.com

3-5-A4 1-3-1/39