

61

ISS	C	A	AA	C	SS	IC
0000	800	10	00	04	03	0204

GENERAL TOL. : FINE / MEDIUM / COARSE CLASS TO IS: 2102

DRG. CONVENTIONS CONFIRM TO INDIAN STANDARDS DIMENSIONS ARE IN mm UNLESS OTHERWISE STATED.

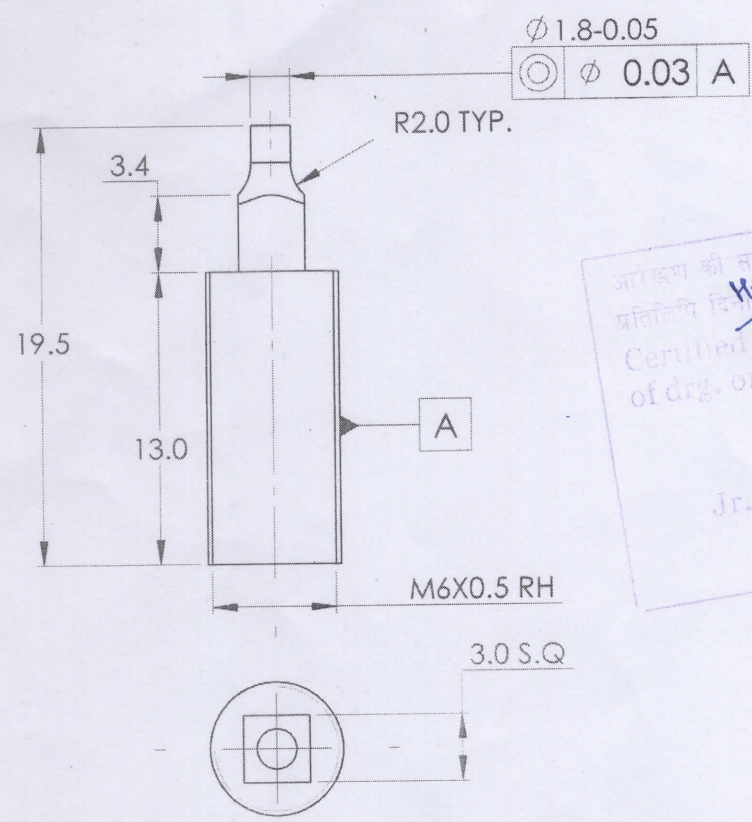

जांच/प्रमाण की तारीख
प्रमाणित किया गया
Certified as correct copy
of drg. on 14/10/19
Jr. Works Manager
STANDARD

NOTES:-

- 1) REMOVE ALL SHARP EDGES AND BURRS.
- 2) HARDNESS : 280-330 HV.
- 3) IF THE COMPONENT IS TO BE MANUFACTURED THROUGH MIM ROUTE, REFER ARDE SPECN No: DRDO/ARDE/MIM/TSP/051/2019.

Sr. No.	DATE	AUTHORITY	BRIEF RECORD	ZONE	CD	GO
					SIGN	

E	DRN: ANKIT SIGN: <i>[Signature]</i> DATE: 07/03/2019	<i>[Signature]</i> CHECKED FOR DIRECTOR EST. MASS 2.67 gm	MATERIAL: STEEL TO IS:5517-1993,Gd-42Cr4Mo2
	APPD. DATE:07/03/2019		PROTECTIVE FINISH: PHOSPHATED TO SPECN. IS:3618-1966, CLASS 'B'
	SEALED DATE: SHEET SIZE: A4 SCALE: 3:1		TITLE: FORE SIGHT
	DESIGN AUTHORITY ARDE PUNE 411021		

DRG No.	0204	03	04	00	01	008	00DA
	IC	SS	S	AA	A	C	SST

JVPC	PART No.	DS CAT No.	AHSP
------	----------	------------	------