

DRG. NO.

V572 0175 7021

SHEET OF

ISSUE

2

1

LINEAR DIMENSIONS	0.5-3	3-6	6-30	30-120	120-315	315-1000	1000-2000
DEVIATIONS IF UNSPECIFIED	± 0.1	± 0.1	± 0.2	± 0.3	± 0.5	± 0.8	± 1.2
DIMENSION							
LIMITS							

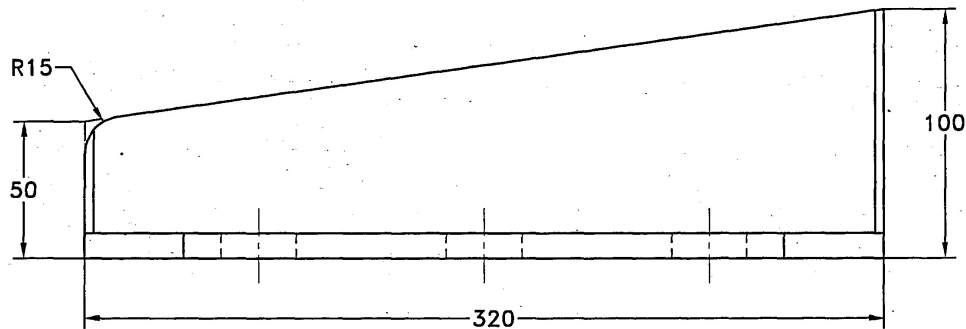
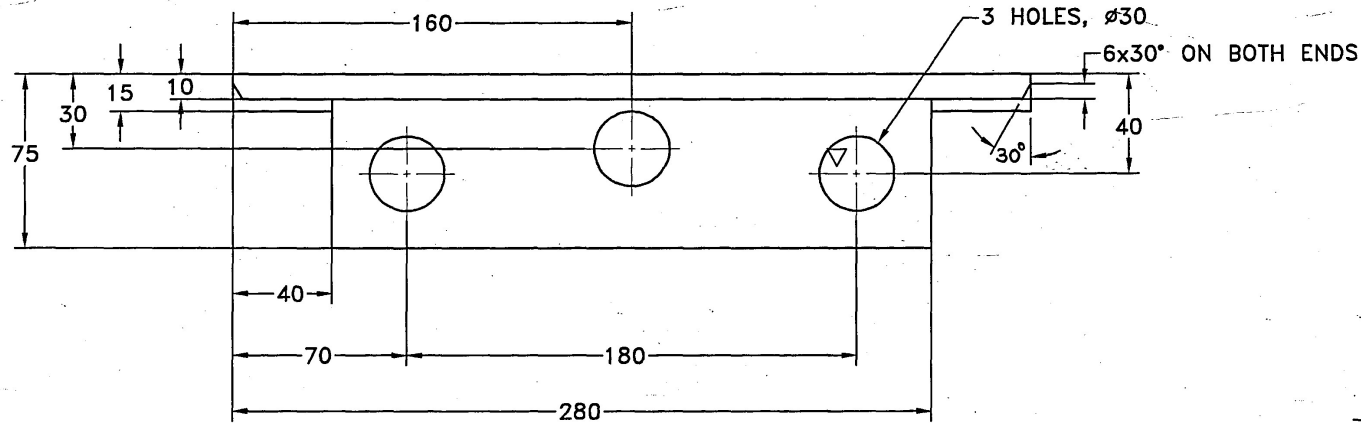

A	11.11.11	Lt.No.55159/CQA(HV)/DB/CIA/T-72 Dt. 15 Sep 2011
ISSUE	DATE	NATURE OF AMENDMENTS

BK

APPROVED FOR BULK PRODUCTION.

04.04.2005

ISSUE AMENDMENTS

SEALED DRG *[Signature]* 8/12/11

NOTE:-

- (a) STEEL TO SPEC IS : 2062 Fe 410. WA
(b) HOT ROLLED UNEQUAL LEG ANGLE TO IS: 808 (PART VI) ISA 10075.
- REMOVE SCALES AND BURRS AFTER MACHINING.
- RED-OXIDE PAINTING IS TO BE DONE TO SPECN. JSS: 3-47-13
CQAEM/SS/133 SHADE CODE-446 FOR PRIMER FINISH (or) IS:2074-1992.

ROUGHNESS SYMBOL	~	▽	▽▽	▽▽▽	▽▽▽▽
ROUGHNESS VALUE	50-25	25-6.3	6.3-0.8	0.8-0.1	< 0.1
MATL	REFER NOTE No.1				
DRN	STS	CAD	AD	DIMENSIONS IN mm.	
CHD	RP	COMP	NB	DRG. NOT TO BE SCALED	
PASSED	R.PANDURENGAN TO 'C'			SCALE	1 : 2
APPROVED	V.R.PREM Kumar Set 'E'			DATE	22.10.2002

Est. wt 2.875 Kg.

STAMP PART NO. MANUFACTURER'S NAME & YEAR

REMOVE ALL BURRS

*USED ON
V572 0175 0118,0318
& 0618 (SHEET 3 OF 3)

TITLE	BARRIER-TAPER-LH	DRG. NO.	V572 0175 7021	ISSUE	
		SHEET OF			

USED ON *
CQA(HV)5.01.004 (A)

COMBAT VEHICLES RESEARCH AND DEVELOPMENT ESTABLISHMENT

2

1