

10.66.20.09.01

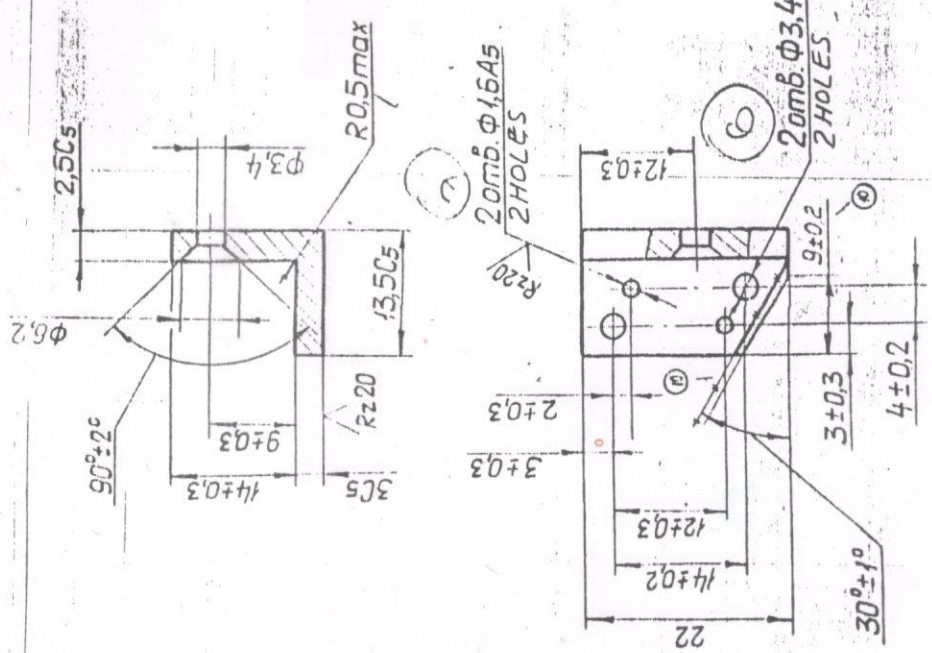

1. PRESSURE DIE CASTING.
CASTING I GROUP OST 3.4227-79
DRAFTS AS PER GOST 3212-80.
2. UNSPECIFIED CASTING RADIUS UP TO 1 mm.
4. UNSPECIFIED LIMIT DEVIATION ON DIMENSIONS:-
OF HOLES-AS PER A7
OF SHAFTS -AS PER B7
THE REST -AS PER CMT
5. COATING: BLACK ANODIC OXIDATION.

1. Литье под давлением по ТН 3212-80
2. Отливка I группы. OST 3.4227-79
Литье - по указанным в ТН 3212-80
3. Неуказанные литейные радиусы - до 1 мм.
4. Неуказанные предельные отклонения размеров:
отверстий - по А7,
валов - по Б7,
остальных - по СМ7.
5. Покрытие: Ан. Окс. черным.

FOR TRADE ONLY
Date of Issue: 13/07/22

Updated on 21.3.99 (Alt. mat. in the hand)
Updated from 18.1.94 with Alt. 2 (UW) 10000
103-3
70-24
Alt. 2/24

*ALT. MAT. 15.136-24345 (W/P)		FOLDER/SHEET NO. 17 26	
DRG. No. 10-62.03.543		SHEET	WEIGHT
ANGLE PLATE		0.005	SCALE
16-617-4600		2:1	
ALLOY A12		OPTO ELECTRONICS FACTORY	
MATERIAL GOST 2685-75		DEGRADATION	
ISSUE	DATE	REFERENCE	
APPROVED	(NS)		
CHECKED			
DRAWN			

* IS 617-94 Designation 4600A
* AUTH. O/A M/O A-I/INSTRUMENTS
Date 31 May 2016.