

TOLERANCES ON UNTOLERANCES DIMENSION ± 0.5 mm

DIMENSION ARE IN MM

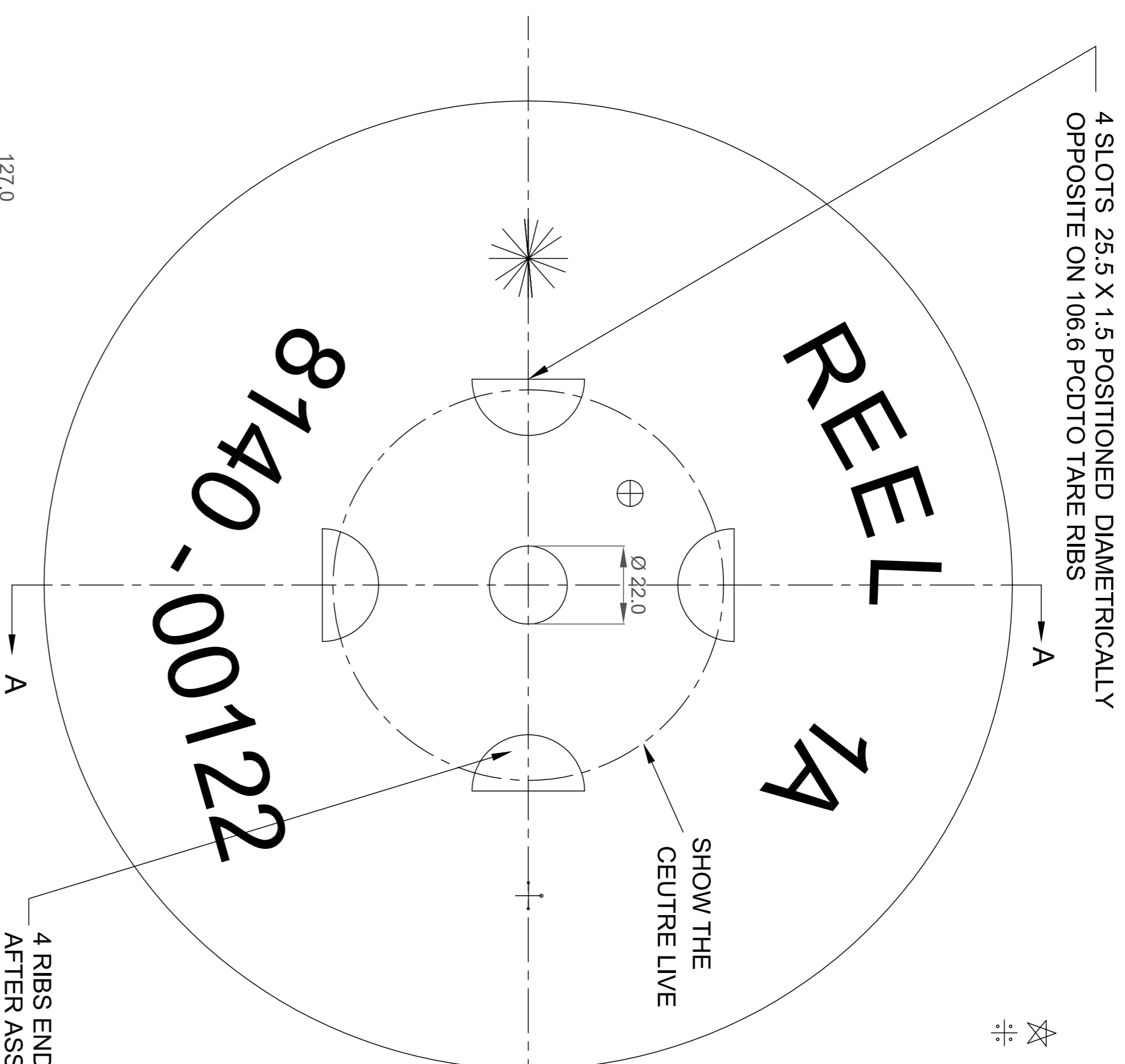
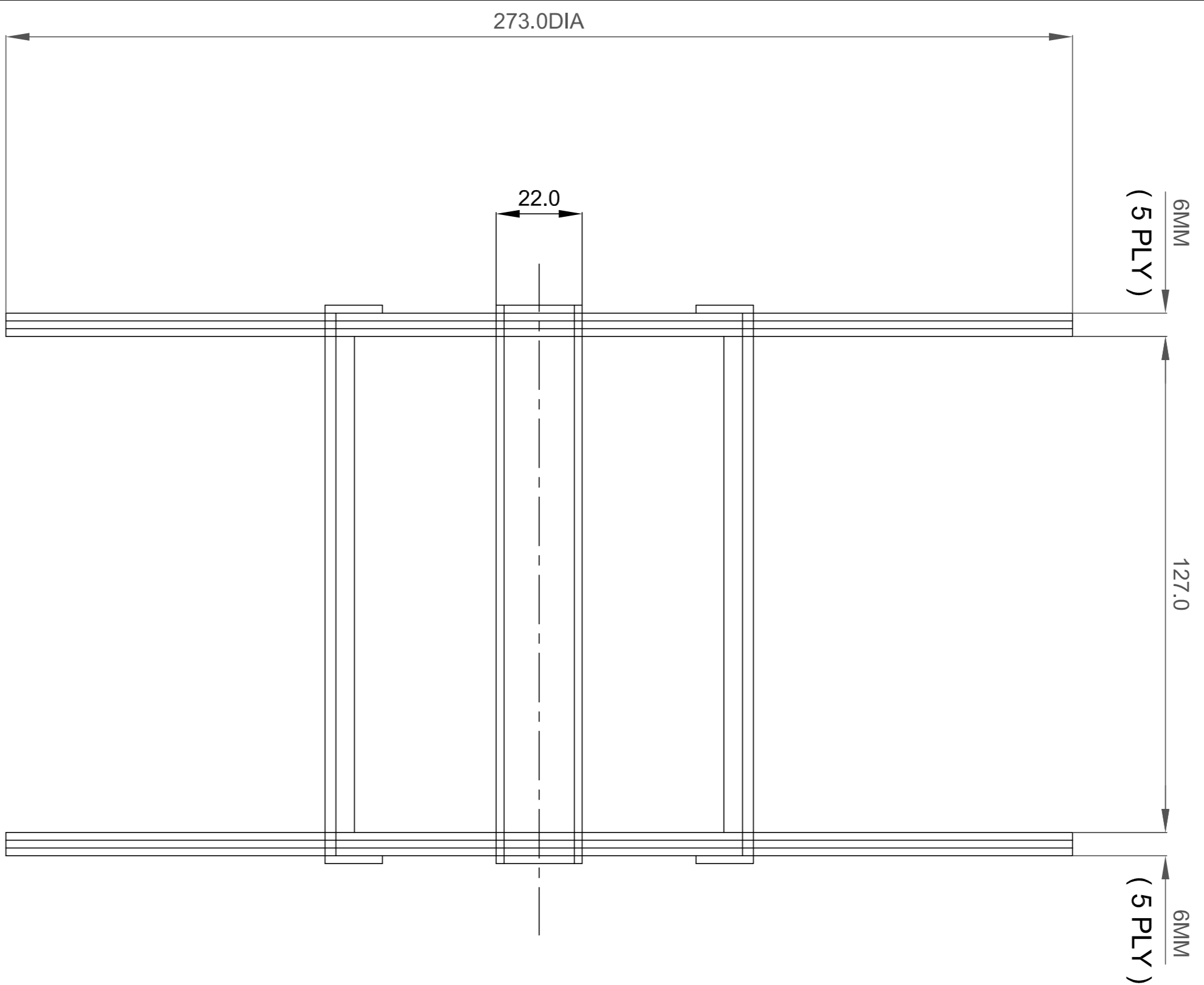

4 SLOTS 25.5 X 1.5 POSITIONED DIAMETRICALLY OPPOSITE ON 106.6 PCDD TO TARE RIBS

MATERIAL

NOTES

RIB:- STEEL CONFORMING TO ANY ONE THE FOLLOWING SPECN
 ☆ IS - 1079-1994 (FIFTH REV) ST 34 HOT ROLLED AND ANNEALED OR
 † IS - 513 1994 (FOURTH REV) COLD ROLLED ANNEALED BEST SURFACE
 D TYPE OR

B5 - 1449 PT 3B -1964 CS4 COLD ROLLED AND ANNEALED OR
 B5 - 1449 PT 3A - 1964 HS4 A HOT ROLLED AND ANNEALED
 STEEL SHOULD BE GALVANISED TO SPECN B5 729 P.T.I. OR
 ZINC PLATED TO SPECN IS 1573 (LATEST ISSUE) GRADE C OR
 PHOSPHATED TO SPECN IA 1279

PLYWOOD :- WWR TYPE BB TO SPECN + IS - 303 - 1989(THIRD REV) REAFFIAMED 1998 &
 AFTER DRILLING ALL HOLES & MACHINING OPERATION THESE SHOULD
 BE DIPPED IN 10% SOLUTION OF COPPER NAPHTHANATE IN
 WHITE SPIRIT OR KEROSENE OIL SUPERIOR FOR A PERIOD OF FIVE MINUTES
 REEL TO BE VARNISHRD ALL OVER WITH VARNISH AIR DRYING
 AMMUNITION TO SPECN ☆ IND / ME / 719 (d) DC 3754 - ME
 DATE :- 12.12.02

2 HOLES 18.0 DIA POSITIONED
 ON ONE SIDE OF REEL
 DIAMET RICALLY OPPOSITE
 ON 86.0 P.C.D.

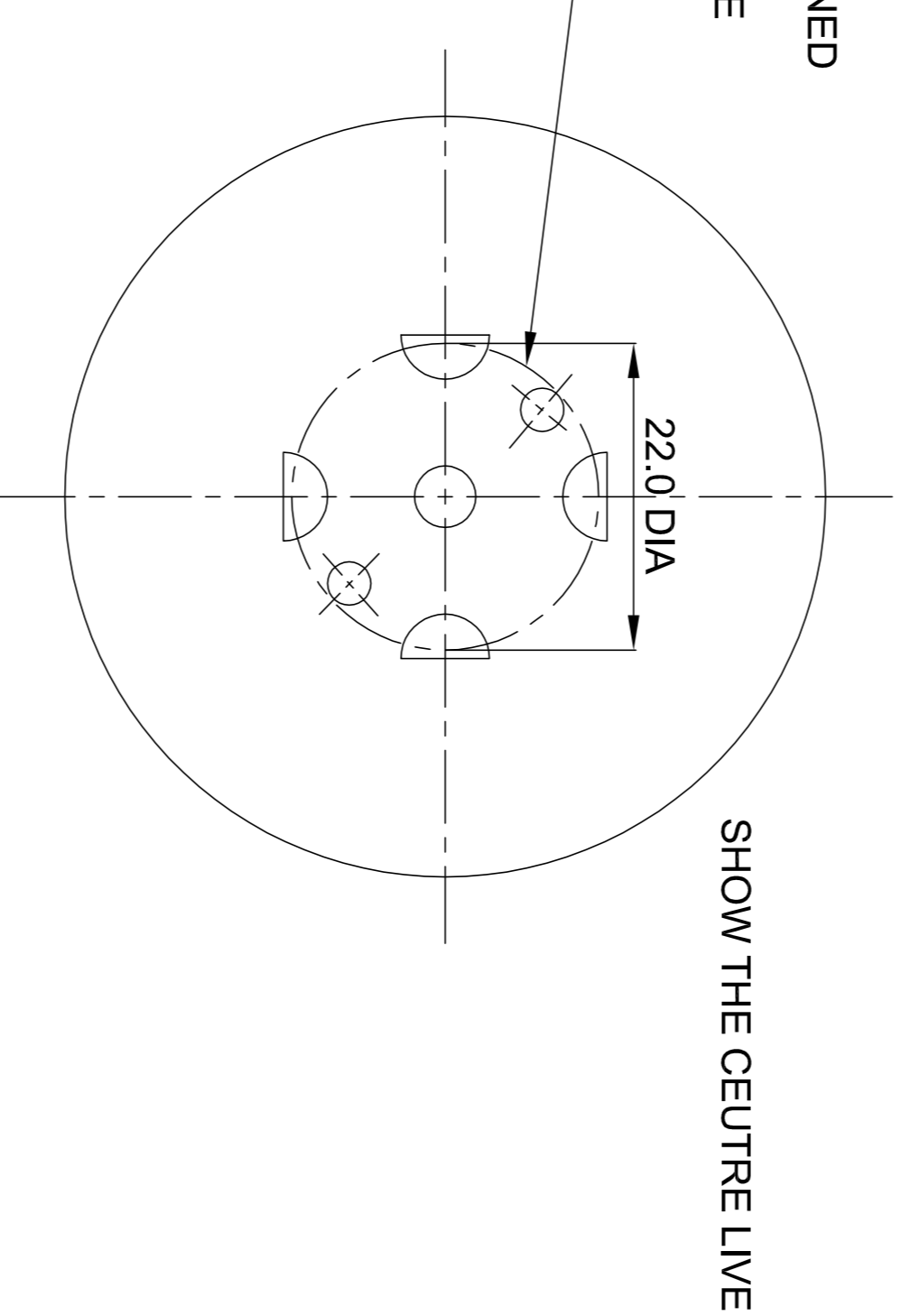

4 RIBS BENT AS SHOWN AFTER ASSEMBLY

TO BE BRANDED OR STAMPED IN 12.5 TYPE

SECTION - 'AA'

CONTRACTOR'S INITIALS OR
 RECOGNISED TRADE MARK
 YEAR OF MANUFACTURE

SERIAL No & DS CAT No
 TO BE STAMPED OR BRANDED IN
 25.5 & 12.6 TYPE ON EITHER
 FACE OF THE REEL RESPECTIVELY

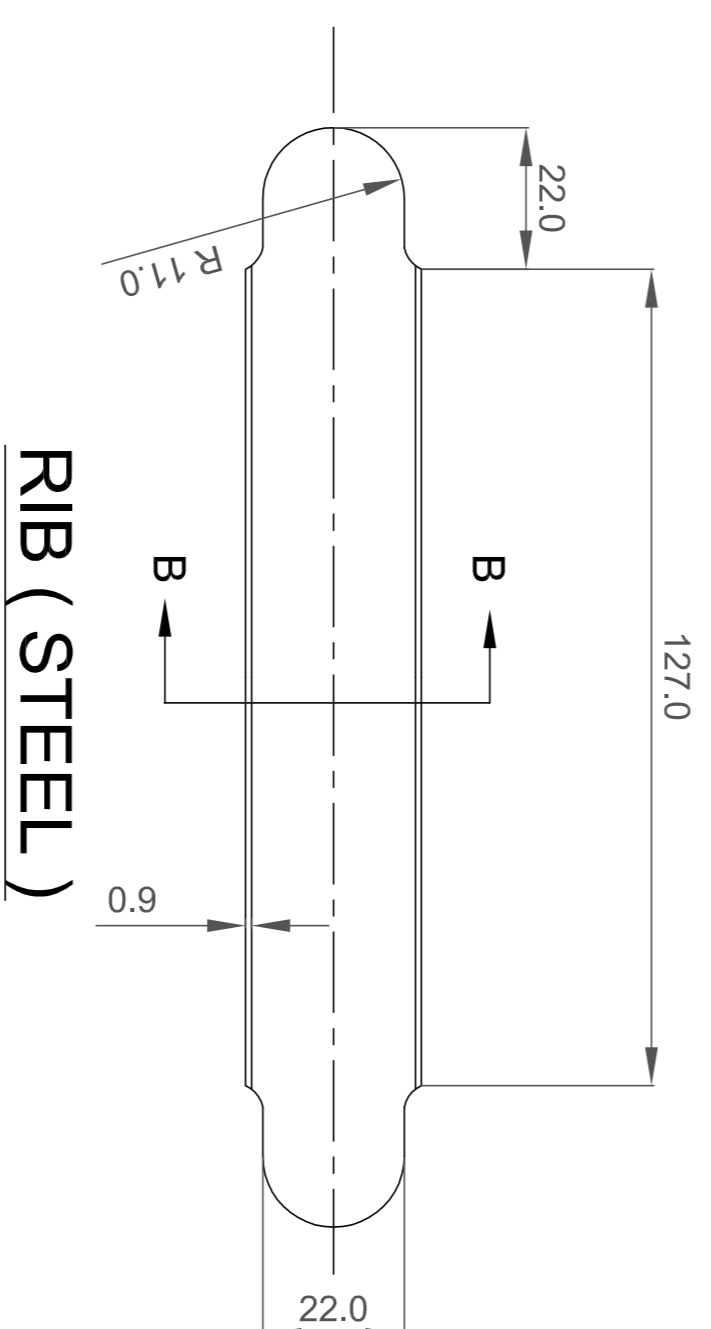

SECTION 'B.B'

RIB (STEEL)

5	14.12.07	☆ MATERIAL SPON CHANGED FROM IND/ ME/719 TO IND / ME / 719 (d) DC: 3754 ME DATE:- 12.12.02
4	14.12.07	± MATERIAL SPON CHANGED FROM IS - 303 TO IS 303 - 1989 (THIRD REV) REAFFIRMED- 1998
3	14.12.07	+ MATERIAL SPON CHANGED FROM IS - 513 - 1963 TO IS - 513 1994 (FOURTH REV)
2	14.12.07	☆ MATERIAL SPON CHANGED FROM IS - 1079 - 1963 TO IS - 1079 - 1994 (FIFTH REV)
1	19.08.05	⊕ SQUARE HOLE □ 22 CHANGED IN TO Ø 22 MM

S.No	DATE	AMENDMENT	SIG	MANAGER ENGG.	GENERAL MANAGER
ORDNANCE FACTORY BHANDARA					
REEL - 1A / L /					
FOR PACKAGE AMMUNITION 79 A					
DATE :- 8.4.93		SCALE :- 1:2			
DRAWN BY :-		DRG NO.			
TRACED BY :-		OFBA/ CX / 54			
CHECKED BY :-					
APPROVED BY :-		FINAL APPROVAL			
Sd/-					

REEL 1A
 8140 - 000122

RIB (STEEL)

ORDNANCE FACTORY BHANDARA
REEL - 1A / L /
 FOR PACKAGE AMMUNITION 79 A

SCALE :- 1:2

DATE :- 8.4.93

DRAWN BY :-

TRACED BY :-

CHECKED BY :-

APPROVED BY :-

CONTRACTOR'S INITIALS OR RECOGNISED TRADE MARK YEAR OF MANUFACTURE

SERIAL No & DS CAT No TO BE STAMPED OR BRANDED IN 25.5 & 12.6 TYPE ON EITHER FACE OF THE REEL RESPECTIVELY

REEL 1A 8140 - 000122