

GENERAL TOL. : FINE / MEDIUM / COARSE
 CLASS TO IS 2102
 DRG. CONVENTIONS CONFORM TO INDIAN STANDARDS
 DIMENSIONS ARE IN mm UNLESS OTHERWISE STATED.

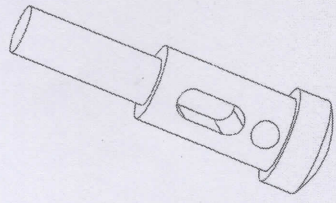

- NOTES:-**
- 1) REMOVE ALL SHARP EDGES.
 - 2) MATERIAL: NYLON - 6,6; REINFORCED WITH 20% LONG GLASS FIBRE
Gd-Repel 312001 HI HSTJBK OR EQUIVALENT.
 - 3) COLOUR TO IS 52007, ISC No. 698 - STEEL GREY.
 - 4) ADDITION OF PIGMENT NOT PERMITTED.

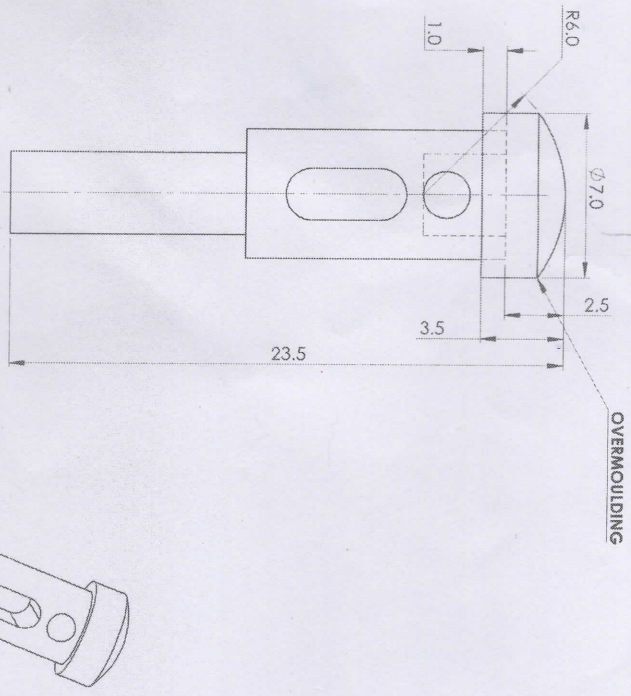
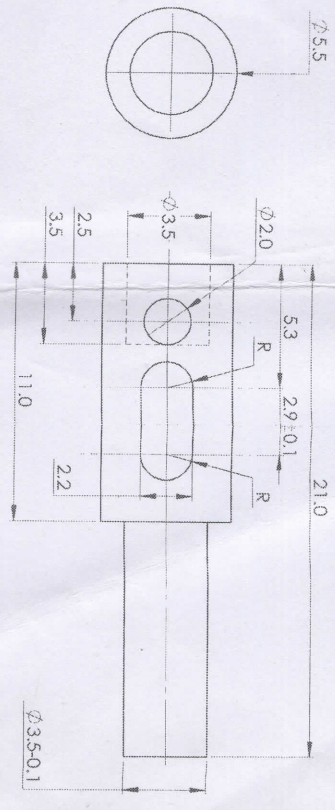

- NOTES:-**
- 1) REMOVE ALL SHARP EDGES AND BURRS.
 - 2) MATERIAL: STAINLESS STEEL WIRE TO IS:4454(Pt. 4):2001, Grade-2

INSERT

अखिल भारतीय प्रमाणन
 प्रमाणन विभाग
 Certified copy
 of drg. on. 19/1/2019
 Jt. Works Manager
 S¹

Sr. No.	DATE	AUTHORITY	BRIEF RECORD	ZONE	CD	GO
DRN: SOURABH	DATE: 07/03/2019	CHECKED	MATERIAL:	SEE NOTES		
SIGN: <i>[Signature]</i>	DATE: 07/03/2019	FOR DIRECTOR	PROTECTIVE FINISH:	SEE NOTES		
APPD. DATE	SEALD DATE	EST. MASS	TITLE:			
SHEET SIZE: A3	SCALE: 5:1		HOLDING OPENING DEVICE (H.O.D)			
DESIGN AUTHORITY	DESIGN AUTHORITY					
ARDE	PUNE 411021					
DRG No. 0204	IC 03	SS 04	S 01	AA 12	A 003	0003
JVPC	PART No.	DS CAT No.	AHSP			

1 2 3 4 5 6 7 8