

FOR TRADE GEN  
Date of Issue 11/06/24  
Jepw

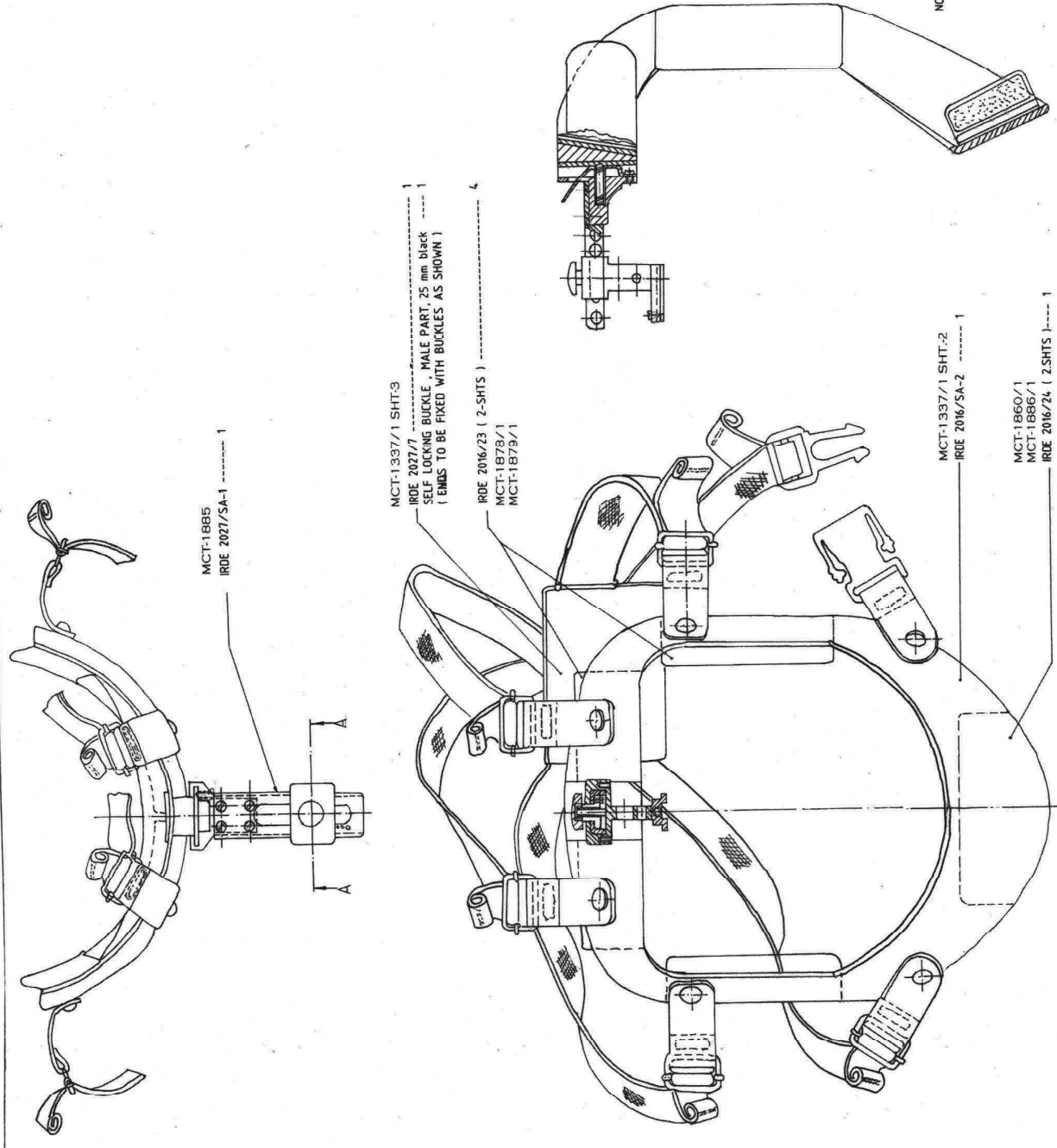

NOTE:-  
(1) ENDS OF STRAPS TO BE STITCHED IN POSITION AS SHOWN.  
(2) ALL BRASS SCREWS, WASHERS & NOT TO BE BRONZED BLACK.  
(3) ALL STEEL SCREWS AND WASHERS TO BE PHOSPHATISED.

ORD. FY. O. DUN	DR. <i>B. S. M. J.</i>	DATE 6-10-93	SCALE 1:1
	TR.	MATL. AS IN DETAILS	TREAT. AS IN DETAILS
CH. <i>S. N. S.</i>	APPD. <i>J. S.</i>	SHEETS 3	SHEET NO. 1
IC/bo	DGM/JPL	DRG. No. MCT/1337	
FACE MASK for GOGGLES N. V. PASSIVE 102A.			
AMENDMENTS O.F.D./Do/002			
DRG. NO. IRDE 2027			

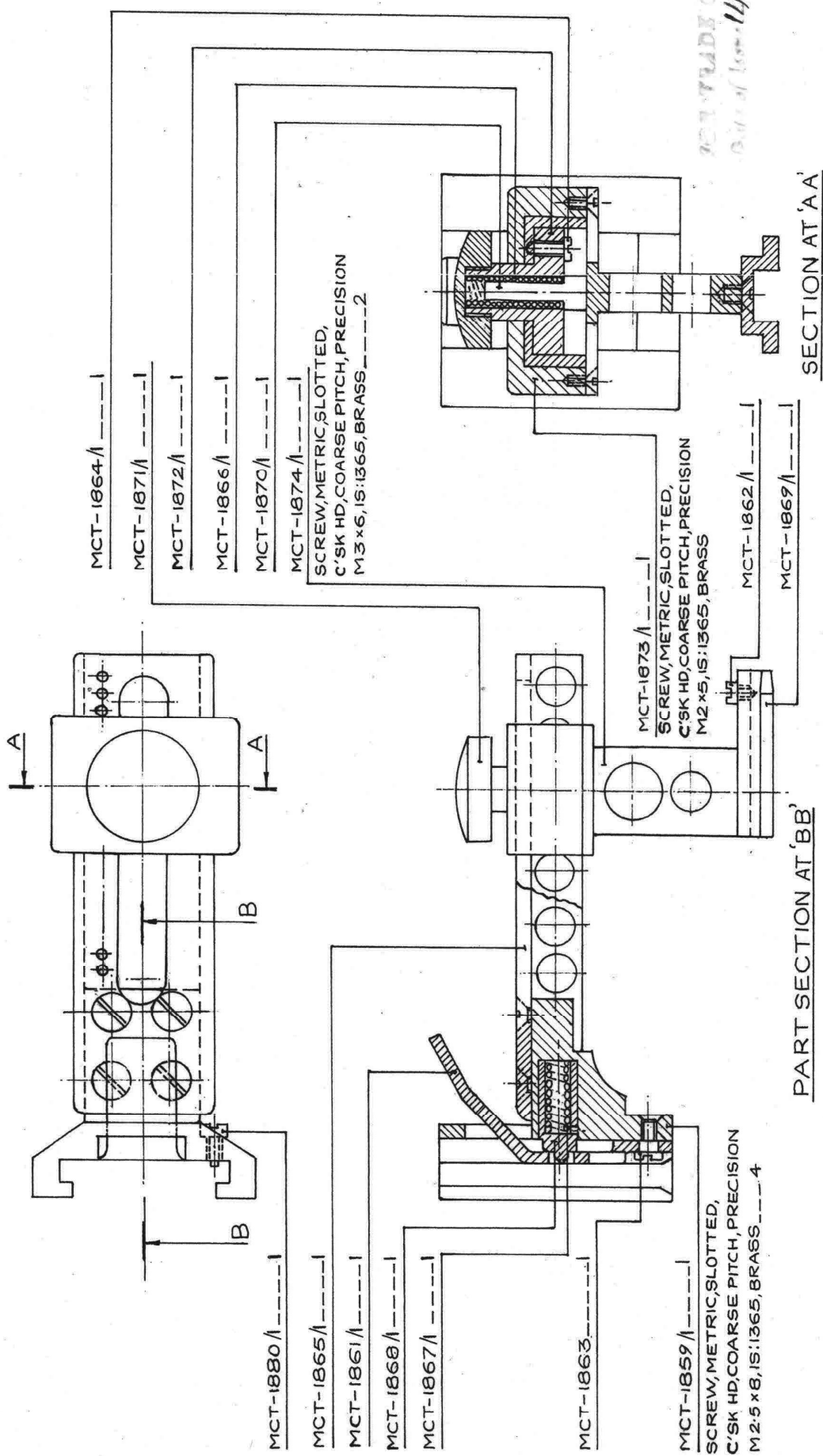

MCT TRADE ITEM  
 Date of Issue: 11/06/20  
 Rymu

SECTION AT 'AA'

PART SECTION AT 'BB'

FACE MASK GOGGLES NIGHT VISION PASSIVE, I02 A

SLIDE ASSEMBLY

8-12-2K - 2:1

DRAWING NO.  
 MCT-1885

AUTHOR  
 oFD/Do/502

DRG. NO.  
 IRDE 2027/SA-1

DATE: 11/06/20  
 BY: N. K. V. / Rymu

ORDNANCE FACTORY, DEHRADUN

L/OUT No.

FACE MASK, GOGGLES N. V. P. 102 A.

DRG. No

IRDE-2016/7

PIN CATCH <sup>(a)</sup>

TITLE OF

OPERATION

THIRD ANGLE PROJECTION

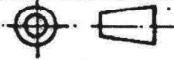

MCT-1864/1



SLOT 1 WIDE X 0.5 DEEP

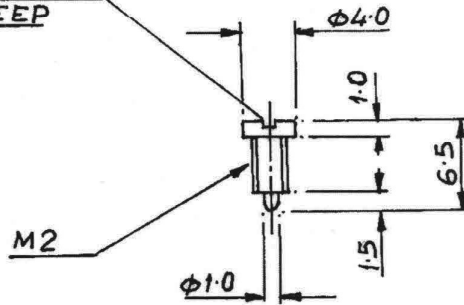

FOR TRADE COPY

Date of Issue 11-6/22

*Opin*

(a)

MATL. STEEL IS: 7283-1974

FINISH - BLACK NICKLE PLATED

DIMENSIONS ARE IN M/M.  
 IMPORTANT DIMENSIONS MARKED THUS ⊕  
 INFORMATION MARKED THUS † TO BE MARKED ON.

DATE-25<sup>TH</sup> 2K SCALE- 2:1

	DR- <i>[Signature]</i>	MATL.	TREAT.
	TR-	AS ABOVE	AS ABOVE
	CH-	SHEETS 1	SHT. No. 1
(a) D.A. No 10/2015 DT. 27.1.2015	APPROVED		DRAWING No.
AMENDMENTS	<i>[Signature]</i> N.K. Vijaya	MCT-1864/1	
OFD/DO/002	JWA/D. O. AWM/ITS		

ORDNANCE FACTORY, DEHRADUN

L/OUT No.

FACE MASK, GOGGLES N. V. P. 102 A.

DRG. No  
IRDE-2016/8

SCREW, SPECIAL

THIRD ANGLE PROJECTION

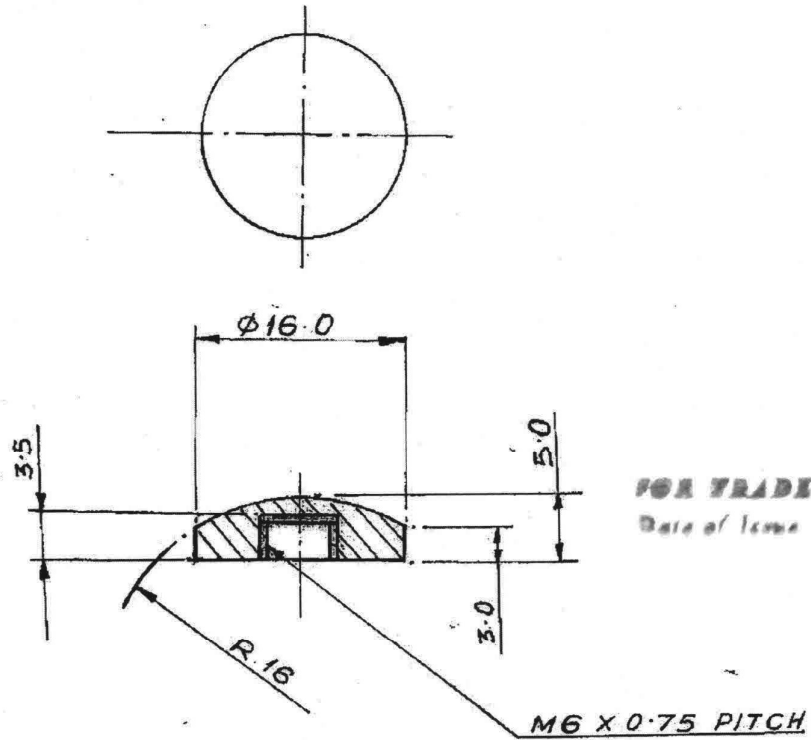
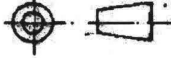

FOR TRADE USE

Date of issue 11/06/17  
Rgus

(\*) MATERIAL ALLOY IS: 733-1983 III REVISION 64430-WP

FINISH: BLACK ANODISED EXCEPT BEARING SURFACES

DIMENSIONS ARE IN M/M.  
IMPORTANT DIMENSIONS MARKED THUS ⊕  
INFORMATION MARKED THUS † TO BE MARKED ON.

	DR- <i>[Signature]</i>	DATE- 24/11/17	SCALE- 2:1
	TR-	MATL. AS ABOVE	TREAT. AS ABOVE
	CH-	SHEETS 1	SHT. No. 1
(Q) D.A. No. 40/2015 DT. 27-1-2015	APPROVED		DRAWING No. <b>MCT-1871/1</b>
AMENDMENTS	<i>[Signature]</i> N. K. Vijaya D. O. ADMITS		
OFD/DO/002			



ORDNANCE FACTORY, DEHRADUN

L/OUT No.

FACE MASK, GOGGLES N. V. P. 102 A.

DRG. No  
1RDE-2016/6

SPRING, HELICAL, COMPRESSION

THIRD ANGLE PROJECTION

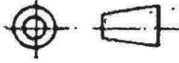

MCT-1866/1

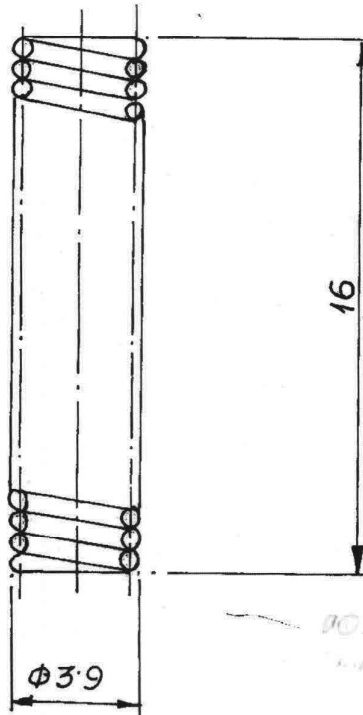
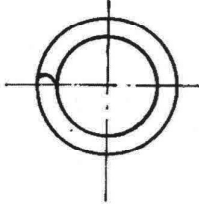

- Φ OF WIRE-0.56
- DEFLECTION PER COIL- 0.1
- LOAD PER COIL - 0.25 Kg
- No. OF EFFECTIVE COIL - 15
- ENDS TO BE SQUARED
- AND GROUND

FOR TRADE COPY  
11/06/2015

(a) MATL: SPRING STEEL IS: 9680-1980  
REAFERRED 1984  
TREAT: HARDENED & TEMPERED

DIMENSIONS ARE IN M/M.  
IMPORTANT DIMENSIONS MARKED THUS ⊙  
INFORMATION MARKED THUS † TO BE MARKED ON

	DR- <i>2/10/15</i>	DATE-28/11/2015	SCALE-5:1
	TR-	MATL. AS ABOVE	TREAT. AS ABOVE
	CH-	SHEETS 1	SHT. No. 1
(a) D.A.No. 10/2015 Dt. 27.1.2015	APPROVED		DRAWING No.
AMENDMENTS	<i>JMN</i>	<i>N.K. Vijja</i>	MCT-1866/1
OFD/DO/002	JMN/D. O.	AWM/TS	

ORDNANCE FACTORY, DEHRADUN

L/OUT No.

FACE MASK, GOGGLES N. V. P. 102 A.

PIN, STRAIGHT <sup>(a)</sup>

DRG. No  
IRDE - 2016/5

THIRD ANGLE PROJECTION

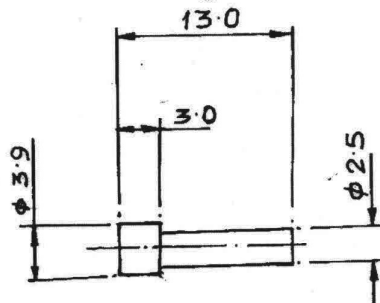
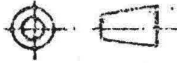

(a)

MATL:- STEEL, IS: 7283-1974.

FINISH:- BLACK NICKEL PLATED.

FOR TRADE OFF

Date of Issue 11/06/17

*Refined*

DIMENSIONS ARE IN M/M.  
IMPORTANT DIMENSIONS MARKED THUS  $\phi$   
INFORMATION MARKED THUS  $\dagger$  TO BE MARKED ON

	DR- <i>Qam</i>	DATE- 25 <sup>11</sup> / <sub>27</sub>	SCALE - 2:1
	TR-	MATL. AS ABOVE	TREAT. AS ABOVE
	CH-	SHEETS 1	SHT. No. 1
(a) D.A. No. 10/2015 DT. 27-1-2015	APPROVED		DRAWING No.
AMENDMENTS	<i>Am</i>	N.K. Vij	MCT-1870/1
OFD/DO/002	JMM/D. O.	AWM/TS	

L/OUT No.

# FACE MASK, GOGGLES N. V. P. 102.A.

## HINGE PLATE

DRG. NO.  
IRDE-2027/3

THIRD ANGLE PROJECTION

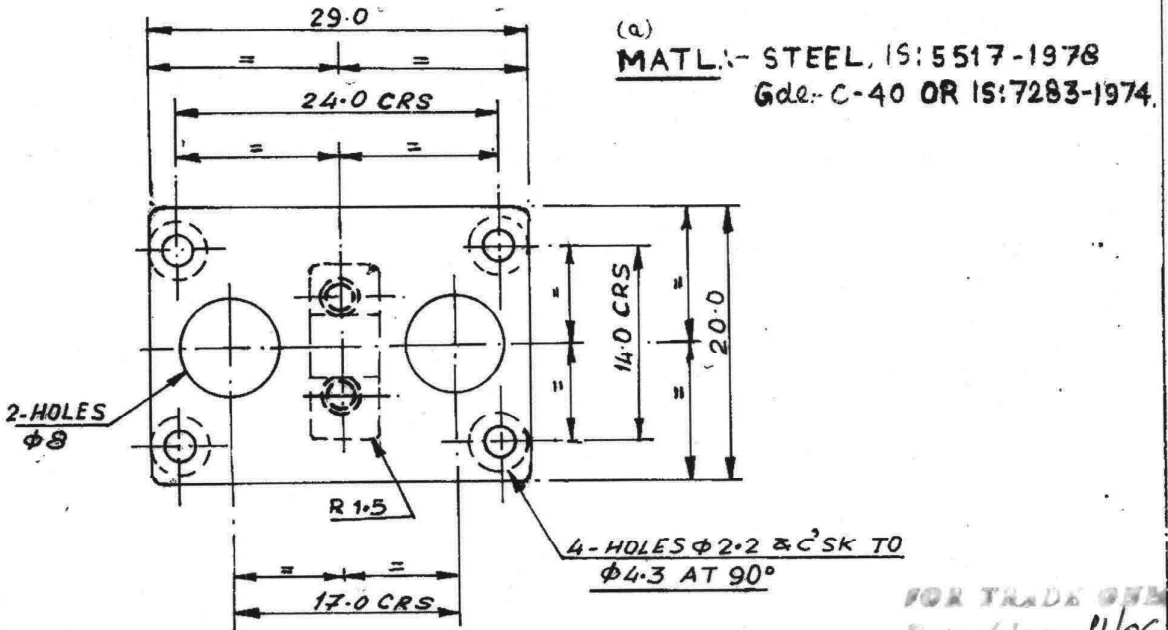
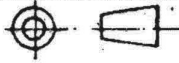

FOR TRADE ONLY

Date of Issue 11/06/14  
*[Signature]*

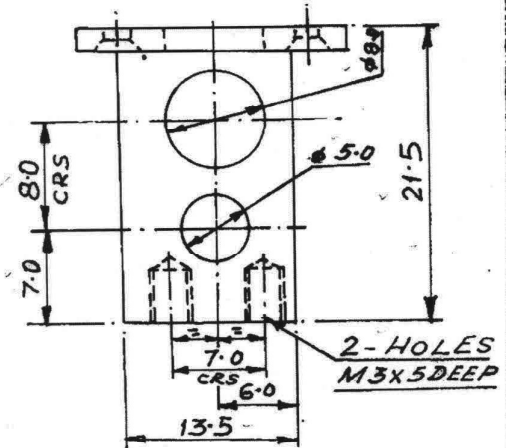
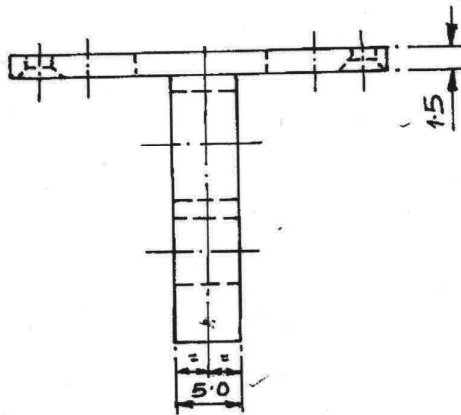

DIMENSIONS ARE IN M/M.  
IMPORTANT DIMENSIONS MARKED THIS  $\odot$   
INFORMATION MARKED THIS  $\dagger$  TO BE MARKED ON

	DR- <i>[Signature]</i>	DATE-26-11-2K	SCALE-2:1
	TR-	MATL. AS ABOVE	TREAT. BLACK NICKLE
	CH-	SHEETS 1	SHT. No. 1
(a) D.A. No. 10/2015 DT. 27.1.2015	APPROVED <i>N.K. Vijaya</i> AM/MTS JMM/D. O.	DRAWING No.	
AMENDMENTS		MCT-1874/1	
OFD/DO/002			

ORDNANCE FACTORY, DEHRADUN

ORDNANCE FACTORY, DEHRADUN

L/OUT No.

# FACE MASK, GOGGLES N.V.P. 102 A.

## SPECIAL SCREW.

DRG. No  
1RDE-2016/27

THIRD ANGLE PROJECTION

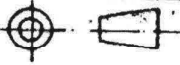

SLOT 0.5 WIDE X 0.5 DEEP.

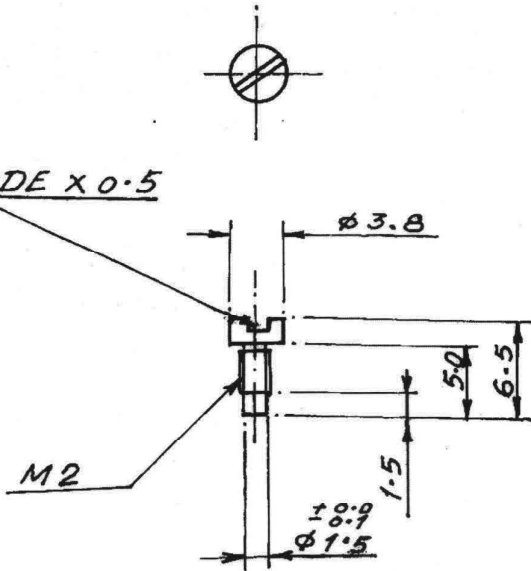

FOR TRADE USE  
Date of Issue 11/06/21  
*Pravin*

MATL:  
SPECN

STEEL IS : 7283-1974.

FINSH: BLACK CHROME PLATED.

DIMENSIONS ARE IN M/M.  
IMPORTANT DIMENSIONS MARKED THUS ⊗  
INFORMATION MARKED THUS † TO BE MARKED ON

		DATE-29 <sup>11</sup> / <sub>2020</sub>	SCALE-2:1
DR- <i>Ratosh</i>		MATL.	TREAT.
TR-		AS ABOVE	AS ABOVE
CH-		SHEETS 1	SHT. No. 1
(a) D.A.No 10/2015 DT. 27.1.2015		APPROVED	
AMENDMENTS		DRAWING No. <b>MCT-1880/A</b>	
OFD/DO/002			
<i>(Signature)</i> JWA/D. O.		N.K. Vijaya AWM/TS	

L/OUT No.

# FACE MASK, GOGGLES NIGHT VISION PASSIVE 102 A CHANNEL

DRG. No: IRDE-2027/1

THIRD ANGLE PROJECTION

ORDNANCE FACTORY, DEHRADUN

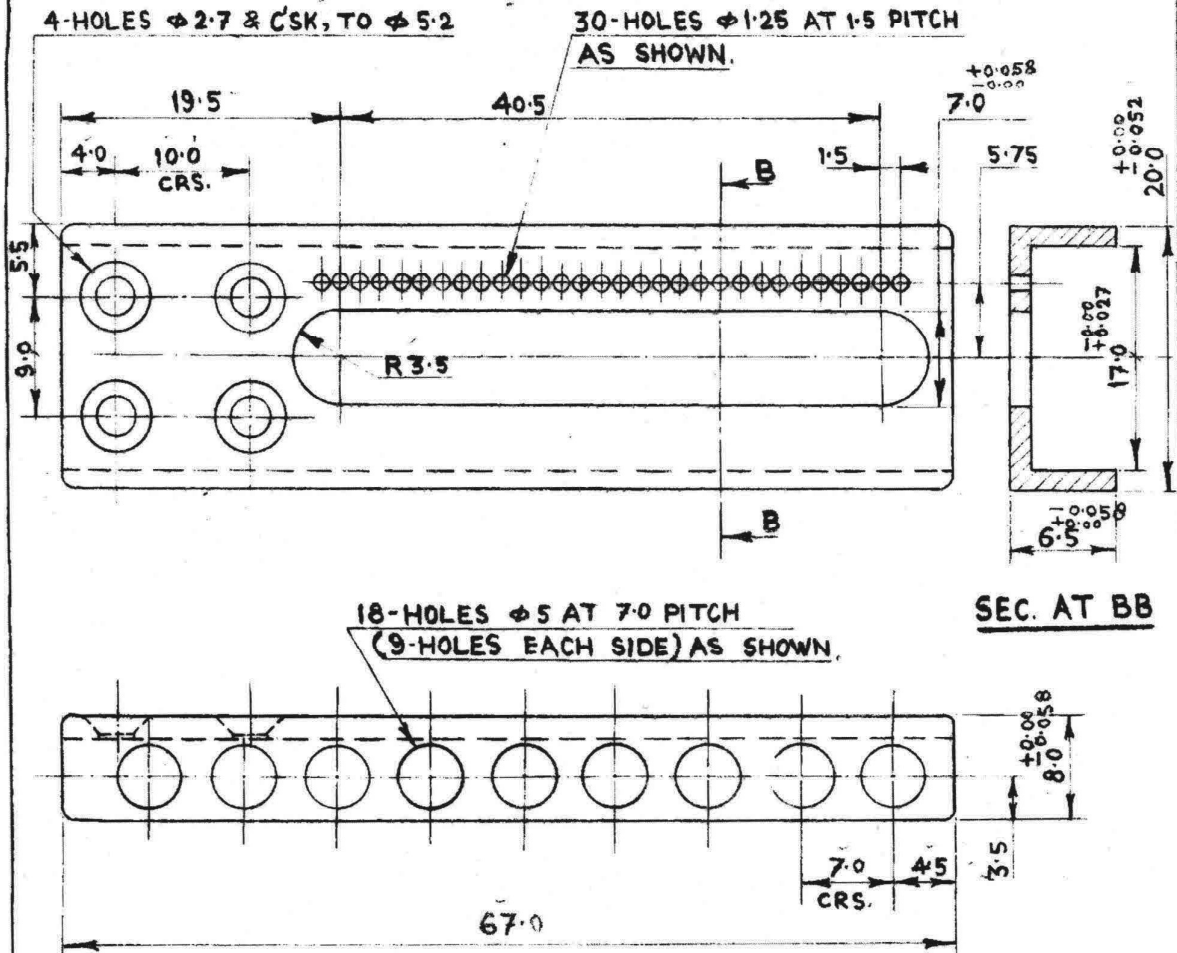

(a)

**MATL** :- STEEL, IS: 5517-1978 Gde. C-40 OR IS: 7283-1974.

**FINISH** :- BLACK OXIDE COATING OR CHEMICAL BLACKING OR BLACK NICKLE PLATED.

DIMENSIONS ARE IN M/M.

IMPORTANT DIMENSIONS MARKED THUS  $\phi$   
INFORMATION MARKED THUS  $\dagger$  TO BE MARKED ON

FOR TRADE MARK  
Date of Issue 11/06/21  
Refuse

		DATE-28/11/2000	SCALE- 2:1
DR- <u>Rokash</u>		MATL. AS ABOVE	TREAT. AS ABOVE
TR-		SHEETS 1	SHT. No. 1
CH-		DRAWING No.	
(a) D.A. No 10/2015 DT. 27.1.2015		MCT-1865/1	
AMENDMENTS		APPROVED	
OFD/DO/002		N.K. Vijaya AWM/TS	

L/OUT No.

# FACE MASK, GOGGLES N. V. P. 102 A.

## LEVER CONTROL HAND (a)

DRG. NO  
IRDE-2016/15

THIRD ANGLE PROJECTION

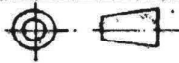

ORDNANCE FACTORY, DEHRADUN

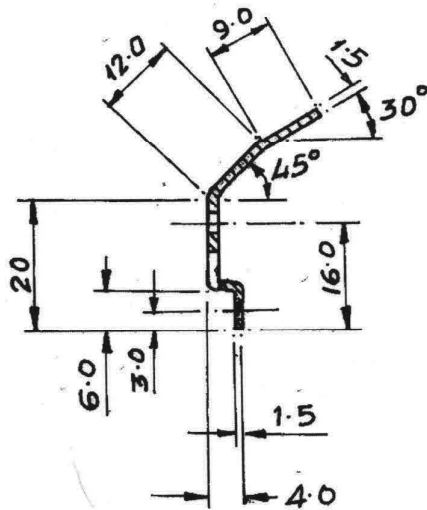

SECTION AT 'A-A'

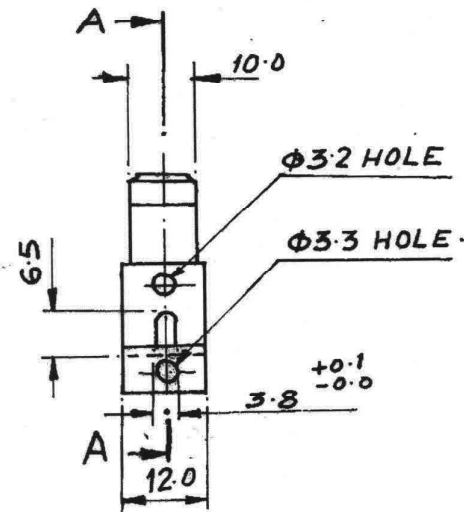

FOR TRADE MARK  
Date of Issue 9/06/15  
*Agarwal*

(a) MATL.:- STEEL, IS: 2507-1975  
REAFFIRMED 1987 Gd&V.

FINISH:- BLACK NICKLE PLATED

DIMENSIONS ARE IN M/M.  
IMPORTANT DIMENSIONS MARKED THUS ⊕  
INFORMATION MARKED THUS † TO BE MARKED ON

	DR- <i>Amr</i>	DATE- 18/11/2015	SCALE- 1:1
	TR-	MATL. AS ABOVE	TREAT. AS ABOVE
	CH-	SHEETS 1	SHT. No. 1
(a) D.A.No.10/2015 DT.27.1.2015	APPROVED		DRAWING No.
AMENDMENTS	<i>Amr</i>	N.K. Vijaya	MCT-1861/1
OFD/DO/002	JMN/D. O.	AWM/TS	